



# City of Denton

City Hall  
215 E. McKinney St.  
Denton, Texas 76201  
[www.cityofdenton.com](http://www.cityofdenton.com)

## Meeting Agenda Public Art Committee

---

Thursday, February 5, 2026

4:00 PM

Civic Center Community Room

---

After determining that a quorum is present, the Public Art Committee of the City of Denton, Texas will convene in a Regular Meeting on Thursday, February 4, 2026, at 4:00 p.m. in the Civic Center Community Room at 321 E. McKinney Street, Denton, Texas, at which the following items will be considered:

### 1. PRESENTATION FROM MEMBERS OF THE PUBLIC

This section of the agenda permits a person to make comments regarding public business on items not listed on the agenda. This is limited to two speakers per meeting with each speaker allowed a maximum of four (4) minutes. Such person(s) shall have filed a "Blue Card" requesting to speak during this period prior to the calling of this agenda item.

### 2. ITEMS FOR CONSIDERATION

- A. [PAC25-022](#) Consider approval of the minutes of August 7, 2025, October 2, 2025 and December 4, 2025.

*Attachments:* [Exhibit 1- August 7, 2025 Minutes](#)  
[Exhibit 2- October 2, 2025 Minutes](#)  
[Exhibit 3- December 4, 2025](#)

- B. [PAC25-027](#) Receive nominations and elect a Chair and Vice-Chair for the Public Art Committee.

*Attachments:* [Exhibit 1- Agenda Information Sheet](#)

- C. [PAC25-023](#) Receive a report, hold a discussion, and give input to staff regarding the status of public art projects at Fire Station #5 and Fire Station #6.

*Attachments:* [Exhibit 1- Agenda Information Sheet Fire Stations](#)  
[Exhibit 2- Fire Station 5 Proposal Catalog](#)  
[Exhibit 3- Fire Station 6 Proposal Catalog](#)

- D. [PAC25-028](#) Receive a report, hold a discussion, and give staff direction regarding the Public Art Committee meeting schedule for 2026

*Attachments:* [Exhibit 1- Agenda Information Sheet](#)  
[Exhibit 2- Ordinance 19-2865](#)  
[Exhibit 3- PAC Meeting Schedule 2026](#)

- E. [PAC25-029](#) Receive a report, hold a discussion, and provide input to staff regarding the status of the following Public Art Committee projects:

1. Current Projects
  - a. Traffic Box Wraps
  - b. Fire Stations #5 and #6

- c. MLK Jr. Recreation Center Mural
- 2. Future Public Art Projects
- a. Linda McNatt Animal Shelter Expansion (Bond-Funded)

Attachments:     [Exhibit 1- Agenda Information Sheet](#)  
                          [Exhibit 2- Presentation](#)

### 3. CONCLUDING ITEMS

A. Under Section 551.042 of the Texas Open Meetings Act, respond to inquiries from the Public Art Committee or the public with specific factual information or recitation of policy, or accept a proposal to place the matter on the agenda for an upcoming meeting AND Under Section 551.0415 of the Texas Open Meetings Act, provide reports about items of community interest regarding which no action will be taken, to include: expressions of thanks, congratulations, or condolence; information regarding holiday schedules; an honorary or salutary recognition of a public official, public employee, or other citizen; a reminder about an upcoming event organized or sponsored by the governing body; information regarding a social, ceremonial, or community event organized or sponsored by an entity other than the governing body that was attended or is scheduled to be attended by a member of the governing body or an official or employee of the municipality; or an announcement involving an imminent threat to the public health and safety of people in the municipality that has arisen after the posting of the agenda.

NOTE: The Public Art Committee reserves the right to adjourn into a Closed Meeting on any item on its Open Meeting agenda consistent with Chapter 551 of the Texas Government Code, as amended, or as otherwise allowed by law.

#### C E R T I F I C A T E

I certify that the above notice of meeting was posted on the official website (<https://tx-denton.civicplus.com/242/Public-Meetings-Agendas>) and bulletin board at City Hall, 215 E. McKinney Street, Denton, Texas, on January 27, 2026, in advance of the three (3) business day posting deadline, as applicable, and in accordance with Chapter 551 of the Texas Government Code.

---

OFFICE OF THE CITY SECRETARY

NOTE: THE CITY OF DENTON'S DESIGNATED PUBLIC MEETING FACILITIES ARE ACCESSIBLE IN ACCORDANCE WITH THE AMERICANS WITH DISABILITIES ACT. THE CITY WILL PROVIDE ACCOMMODATION, SUCH AS SIGN LANGUAGE INTERPRETERS FOR THE HEARING IMPAIRED, IF REQUESTED AT LEAST TWO (2) BUSINESS DAYS IN ADVANCE OF THE SCHEDULED MEETING. PLEASE CALL THE CITY SECRETARY'S OFFICE AT 940-349-8309 OR USE TELECOMMUNICATIONS DEVICES FOR THE DEAF (TDD) BY CALLING 1-800-RELAY-TX SO THAT REASONABLE ACCOMMODATION CAN BE ARRANGED.



**City of Denton Parks, Public Art Committee**  
**Minutes**  
**August 7, 2025**

---

After determining that a quorum of the City of Denton, Texas, Public Art Committee was present, the Committee convened in a Special Called Meeting on Tuesday, August 7, 2025, at 4:00 p.m. in the Civic Center Community Room at 321 E. McKinney Street, Denton, Texas.

**Present:** Chair Jennifer Lane, Vice-Chair Adam Chamberlain, Members Jordan Gill, Susan Thornton, Will Milne, and Travis Veselka

**Absent:** Connor Bradford and Francesca Romano

**1. PRESENTATIONS FROM MEMBERS OF THE PUBLIC**

- None

**2. ITEMS FOR CONSIDERATION**

A. PAC25-016: Consider approval of the minutes of May 22, 2025, and June 24, 2025.

Item was presented; and discussion followed.

Following discussion, Member Chamberlain moved to adopt the item as presented; Member Milne seconded. Motion carried.

AYES (6): Chair Lane, Vice-Chair Chamberlain, Members Gill, Thornton, Milne, and Veselka

NAYS (0):

ABSENT (2): Members Bradford and Romano

B. PAC25-020: Introduction of Public Art Committee members and Parks staff.

The item was presented, and discussion followed.

Following discussion, there was no direction provided as the item was for discussion purposes.

C. PAC25-021: Receive a report, hold a discussion, and provide input to staff regarding the status of the following Public Art Committee projects:

1. Current Projects
  - a. Traffic Box Wraps
  - b. BNSF/Noblewins Bench Installation
  - c. Fire Stations #5 and #6
  - d. MLK Jr. Recreation Center Mural
  - e. The Art Room - ALH Senior Center
  - f. Halloween Denton
2. Arts Maintenance Projects
  - a. Bench People repair

Item was presented; and discussion followed.

Following discussion, staff was provided the following direction:

- Consider speaking to the Fire Department about including retired firefighter, Ken Gold, on subcommittee.

- Adam Chamberlain, Krissi Oden, and Travis Veselka will be on the fire station art subcommittee. Omar will ask Francesca if she would like to be on the subcommittee; if not, Will Milne will be added to the subcommittee.

### 3. CONCLUDING ITEMS

- None

With no further business, the meeting was adjourned at 4:48p.m.

---

JENNIFER LANE  
CHAIR  
CITY OF DENTON, TEXAS

---

ROBIN HILL  
ADMINISTRATIVE ASSISTANT  
CITY OF DENTON, TEXAS

MINUTES APPROVED ON: \_\_\_\_\_

**City of Denton**

**Public Art Committee**

The Public Art Committee of the City of Denton, Texas, was noticed to convene in a meeting on Thursday, October 2, 2025, at 4:00pm in The Community Room at the Denton Civic Center, 321 E. McKinney St., Denton, TX. The following attendance was recorded:

**PRESENT:** *Chair Jennifer Lane, Members Frances Romano, Travis Veselka, and Will Milne*

**ABSENT:** *Vice-Chair Adam Chamberlain, Members Susan Thornton, Connor Bradford*

Attendees waited until 4:20pm for a quorum of members to arrive.

A quorum failed to materialize, no action was taken, and the meeting was adjourned at 4:20pm.

\_\_\_\_\_  
*Jennifer Lane*  
CHAIR

\_\_\_\_\_  
*Robin Hill*  
RECORDING SECRETARY

MINUTES APPROVED ON: \_\_\_\_\_

**City of Denton**

**Public Art Committee**

The Public Art Committee of the City of Denton, Texas, was noticed to convene in a meeting on Thursday, December 4, 2025, at 4:00pm in The Community Room at the Denton Civic Center, 321 E. McKinney St., Denton, TX. The following attendance was recorded:

**PRESENT:** *Chair Jennifer Lane, Vice-Chair Adam Chamberlain, Members Susan Thornton, and Travis Veselka*

**ABSENT:** *Members Andrew Beck, Connor Bradford, Francesca Romano*

Attendees waited until 4:20pm for a quorum of members to arrive.

A quorum failed to materialize, no action was taken, and the meeting was adjourned at 4:20pm.

\_\_\_\_\_  
*Jennifer Lane*  
CHAIR

\_\_\_\_\_  
*Robin Hill*  
RECORDING SECRETARY

MINUTES APPROVED ON: \_\_\_\_\_



# City of Denton

City Hall  
215 E. McKinney Street  
Denton, Texas  
www.cityofdenton.com

---

## AGENDA INFORMATION SHEET

**DEPARTMENT:** Parks and Recreation  
**ACM:** Christine Taylor, Assistant City Manager  
**DATE:** February 5, 2026

### **SUBJECT**

Receive nominations and elect a Chair and Vice-Chair for the Public Art Committee.

### **BACKGROUND**

The Public Art Committee elects a chairperson and vice-chairperson from its members annually. The Boards, Commissions, and Council Committees Handbook requires:

#### **Election of Officers**

*Procedures for the election of officers for appointed boards are established to ensure consistency with the City Council's goals and policies in making board appointments. Except where otherwise provided by state law, federal law, City Charter, or City ordinances or resolutions, election of officers for City of Denton council-appointed boards will be as follows:*

- *The chair and vice-chair will be elected by voting board members.*
- *Election of officers shall be annually as soon as practicable after the annual appointment process. If, for any reason, the chair or vice-chair vacates their seat, a special election should be held to fill the unexpired term. A temporary chair may be selected by the board pursuant to Roberts Rules of Order.*

Today, the Public Art Committee is asked to elect those individuals to serve the roles of a Chair and Vice-Chair throughout the 2026 calendar year.

### **EXHIBITS**

Exhibit 1 – Agenda Information Sheet

Respectfully submitted:  
Allison Wing, Interim Director Parks and  
Recreation

Prepared by:  
Omar Siddiqi, Admin. Analyst



# City of Denton

City Hall  
215 E. McKinney Street  
Denton, Texas  
www.cityofdenton.com

## AGENDA INFORMATION SHEET

**DEPARTMENT:** Parks and Recreation  
**ACM:** Christine Taylor, Assistant City Manager  
**DATE:** February 5, 2026

### SUBJECT

Receive a report, hold a discussion, and give staff direction, on the selection of winning proposals for bond-related public art at Fire Station 5 and Fire Station 6.

### BACKGROUND

The 2023 Bond program, approved by voters in November of that year, included several vertical construction projects with related public art components. Call for Artists for two of these projects – Fire Station 5 and Fire Station 6 – closed at the end of June. We received 30 proposals for Fire Station 5, and 27 proposals were received for Fire Station 6.

A committee composed of PAC Members and Fire staff met to consider the proposals for both Fire Stations in late September. Each work was assessed according to a simple 100-point rubric, with the points breaking down as follows:

<u>Criteria</u>	<u>Max Points</u>
Artistic Merit	50
Following Project Scope / Theming	25
Proposal Scale and Appropriateness of Scale	25
<b>Total</b>	<b>100</b>

The budget for public art projects at each fire station is \$253,000, and the RFP entertained proposals between \$100,000 and \$200,000.

### *Fire Station 5*

Fire Station 5 will be a new structure built on the parcel of land that houses the current Fire Station 5 located at the intersection of N. Bonnie Brae Street and W. Windsor Drive, near the southwestern corner of North Lakes Park. A subcommittee consisting of Public Art Committee members and Fire Department staff met on October 24 to consider and rank Fire Station 5 proposals.

### *Fire Station 6*

Fire Station 6 is a new structure at 2301 Hunter’s Creek Road, off Teasley Lane. A subcommittee consisting of Public Art Committee members and Fire Department staff met on September 24, 2025, to consider and rank Fire Station 5 proposals.

### RESULTS OF SUBCOMMITTEE RANKINGS

A subcommittee consisting of PAC members Adam Chamberlin and Francesca Romano, GDAC executive director (and PAC ex-officio member) Krissi Oden, as well as Fire Department representatives Chief David Boots and Fire Administration Manager Lindsey Garrison met on September 24, 2025 to consider proposals

for both fire stations. After a conversation about each design, subcommittee members were asked to provide their rankings for each fire station. The consolidated scores for the top three projects at each fire station are provided below, in descending order:

<b>Fire Station #5 Subcommittee Proposal Scores</b>						
<b>Artist</b>	<b>Panelist 1</b>	<b>Panelist 2</b>	<b>Panelist 3</b>	<b>Panelist 4</b>	<b>Panelist 5</b>	<b>Total Score</b>
Denton Maker Center	100	92	95	87.5	90	<b>464.5</b>
SV Randall Studio LLC	80	86	90	60	0	<b>316</b>
Edavant LLC	0	60	57	52.5	100	<b>269.5</b>

<b>Fire Station #6 Subcommittee Proposal Scores</b>						
<b>Artist</b>	<b>Panelist 1</b>	<b>Panelist 2</b>	<b>Panelist 3</b>	<b>Panelist 4</b>	<b>Panelist 5</b>	<b>Total Score</b>
Di Bari Innovation Design LLC	100	87	85	55	0	<b>327</b>
Christine Sanders	85	90	80	67.5	0	<b>322.5</b>
SV Randall Studio LLC	70	91	75	62.5	0	<b>298.5</b>

Images of the designs are attached (see **Exhibit 2** and **Exhibit 3**)

**NEXT STEPS**

After the Public Art Committee considers the top-ranked proposals and if they decide to approve the subcommittee’s selections, procurement staff will work to create contract documents for each project with the winning artists and bring ordinances approving those contracts to council for final consideration.

**RECOMMENDATION**

Staff recommends accepting the subcommittee’s ranked findings and beginning the process to contract with the winning artist for each fire station project.

**FISCAL INFORMATION**

Each Fire Station project has a total bond-supported budget of \$253,000. This budget must support the cost of project fabrication, transportation, and installation, as well as the artists’ fees and other related costs. Additionally, each new piece of public art will have a related maintenance expense during its life span. The bond-supported budget amount does not include maintenance costs which have, historically, come from other funding sources like Hotel Occupancy Tax (HOT) funds.

**EXHIBITS**

- Exhibit 1- Agenda Information Sheet
- Exhibit 2- Fire Station 5 Proposal Catalog
- Exhibit 3- Fire Station 6 Proposal Catalog

Respectfully submitted:  
Allison Wing, Interim Director,  
Parks and Recreation

Prepared by:  
Omar Siddiqi, Admin. Analyst,  
Parks and Recreation



# **FIRE STATION #5**

## **CATALOG OF PROPOSALS**

### **INTERNAL LINKS TO FULL PROPOSALS**



1. 220 Designs  
Manchaca, TX  
Proposal Link: [Denton concept art 4-25-25.pdf](#)  
**Fullered Steel Badge Sculpture**  
Total Budget: \$124,180.00

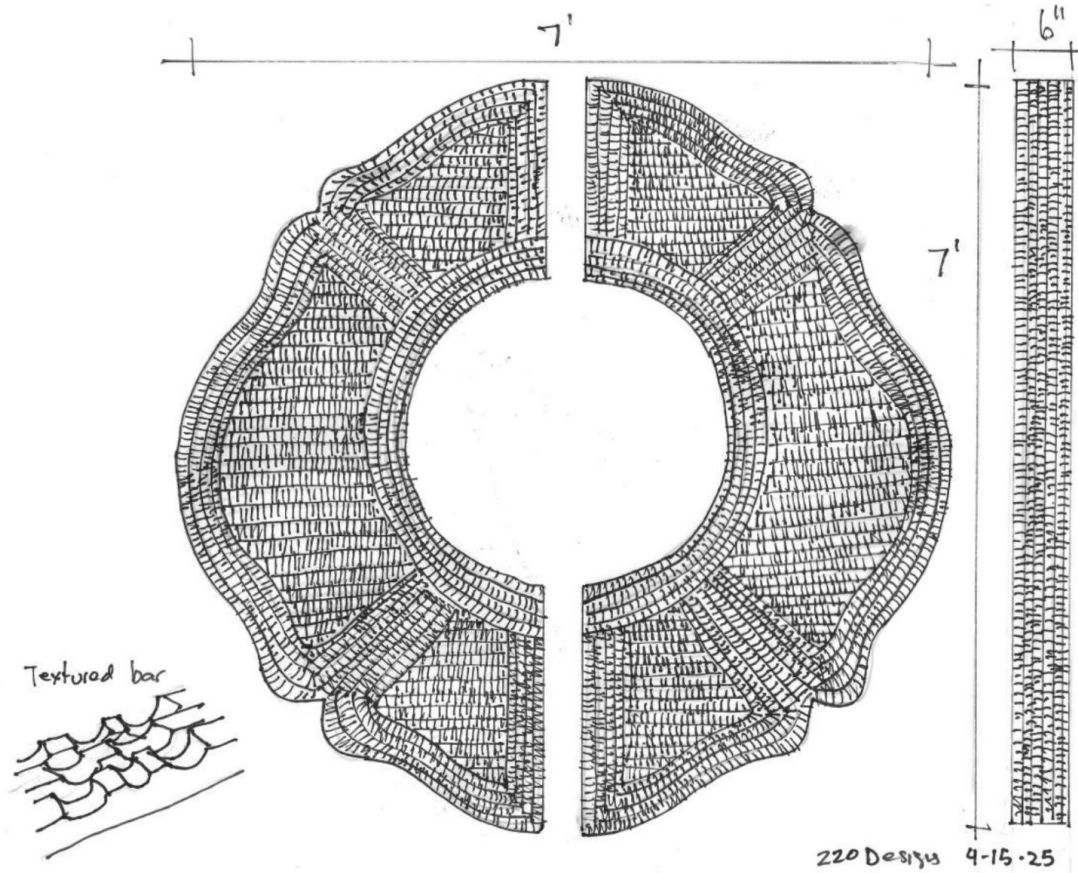



## Proposal for Public Art Installation at Denton Fire Station

### Fullered steel badge sculpture

#### Overview:

The proposed artwork consists of a 7-foot stainless steel badge sculpture crafted from hand forged and textured stainless steel bar designed to be site-specific, harmonizing with its surroundings to create a unique and engaging work of art.

#### Variations and Customization:

- Scalability: This sculpture can be scaled up or down to fit site location for alternative visibility options.
- Color Options: The sculpture can be powder-coated in different colors, adding vibrancy and making the piece stand out in its surroundings.
- Lighting: If required, I can design and install lighting to highlight the artwork, pending further site details and an additional proposal.

#### Installation and Durability:

- Material and Fabrication: The sculpture will be constructed from brushed stainless steel, chosen for its ability to sparkle in daylight and reflect lights at night, creating a captivating visual effect. The fabrication time will be 4-6 months. Progress photos will be made to show progression.
- Maintenance: The brushed finish helps hide scratches from interaction, making the sculptures virtually maintenance-free. It will

**1 3 0 1 b l a c k b e a r , m a n c h a c a , t x 7 8 6 5 2**  
**5 1 2 . 4 1 3 . 7 6 2 5**

2. 23 Design Co

Denton, TX

3D Video: <https://www.youtube.com/watch?v=vVLJ2T9YE3g>

Proposal Link: [Fire Station 5 - Brandon Taylor.pdf](#)

Total Budget: \$199,193.60

**The Answering Wave and The Constant Call**





THE CONSTANT CALL



THE CONSTANT CALL

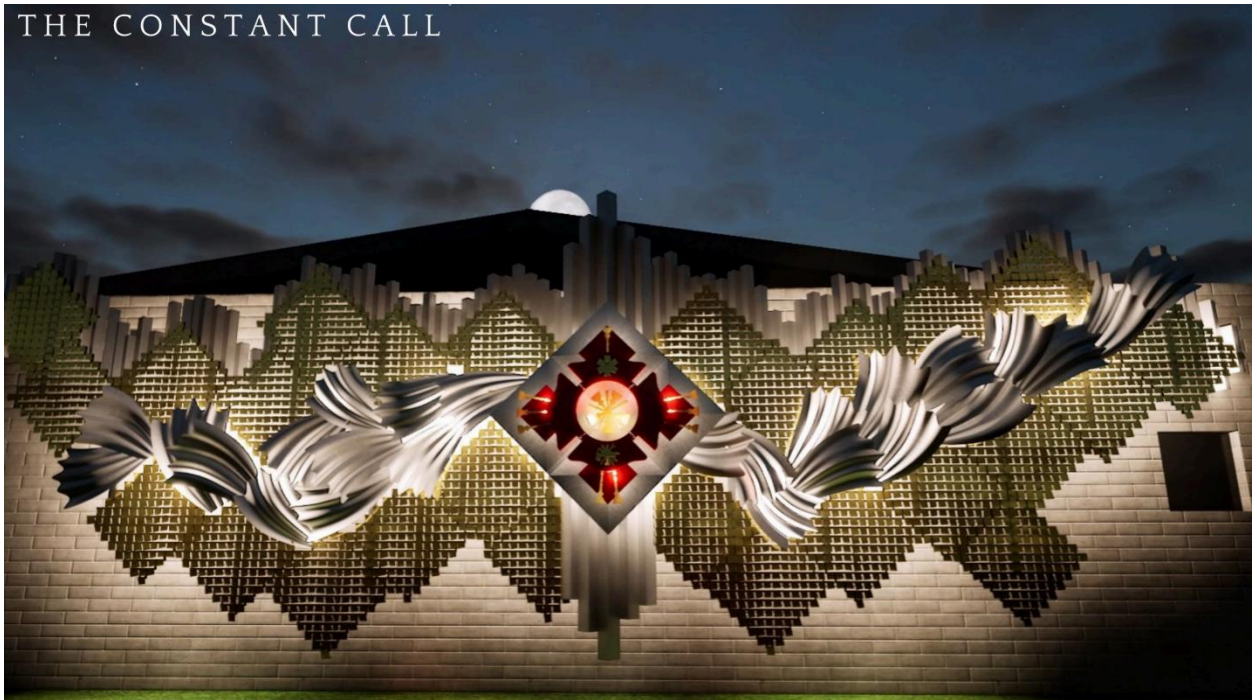

# THE ANSWERING WAVE TO THE CONSTANT CALL

The vision is a dialogue inspired from historic wall reliefs, symbols, and Station 5's history. The fire rescue community is represented in these forms to reflect its complexity and order of communication, which is critical in the daily operation of the departments. Over 20,000 calls were handled last year in Denton. A 24/7, 365 day a year operation. The conditions, details, personnel, weather, on and on handled each day to react, to be present, to expand... wow.

This is a homage depicting this beautiful orchestra in a contemporary dialogue.

The Constant Call radiates from a central layered form of symbols and insignia prevalent to the working history of fire departments. Bugles calling in all directions, communicating orders to all personnel who adapt constantly to the ever changing winds of the expanding city above. Water unifies their connection, not only because it's an inherent necessity to fighting fires, but as a symbol in itself. The endless unifying rhythmic strength, everyday, every night, steady as The Answering Wave.

A few notes;

The kinetic panels symbolize community personnel who constantly adapt to each situation and who are unified under that demand. Water as a complementing symbol is implied as their presence in both pieces.

The central Chief insignia of the 5 crossed bugles is to carry forward the dedication of Station 5 to Chief Jack Gentry in 1990.

Thank you all for your consideration,

Brandon Taylor

### 3. 900 North Studio & Alicia Eggert Indianapolis, IN and Denton, TX

Proposal Link:

Total Budget: \$161,439.51

#### **Be The Light**

The text will be fabricated in glowing white neon and animated to flash and change between "SEE IT" and "BE IT." The rhythm of the words flashing on and off will be meditative in nature, encouraging people to pause and reflect on their meaning. The poem emphasizes the importance of seeking out and embracing good despite darkness and challenges. It champions bravery, empathy, and positive change; urging us to "be the light".

Installing Be the Light at Denton Fire Station #5 would give me the rare opportunity to develop a sculpture that is visually compelling, collaborative, and supportive of our nation's vital first responders. It will be inspirational to a steady stream of passersby, visitors to the fire station, and most importantly, the firefighters themselves. Be the Light is dynamic, thought provoking, and celebratory, and I believe it will powerfully commemorate the hard work and bravery of Denton's firefighters.

The project at Denton Fire Station #5 is particularly meaningful to me, because Denton is my home. It's where I live and work, and where I've chosen to raise my son. As a professor of Sculpture at the University of North Texas and a former member of Denton's Public Art Committee, I am committed to the creative growth of younger generations, and to contributing to the vibrant cultural atmosphere of the city. A public art commission would allow me the rare opportunity to give back to my hometown, my community, and my neighbors.

Be the Light is a large-scale neon sign sculpture designed in collaboration with celebrated poet and children's book author, Amanda Gorman. The last line of Amanda's poem, The Hill We Climb, was the initial inspiration for the sculpture, which states, "...for there is always light if only we're brave enough to see it, if only we're brave enough to be it." I have received Gorman's permission to modify her original poem in a few small ways to make it more legible and discernable from a distance. The sign will read:



THERE IS  
ALWAYS LIGHT  
IF WE ARE  
BRAVE ENOUGH  
TO SEE (BE) IT



4. Beth Nybeck  
Kansas City, MO  
Proposal Link: [Denton 5 Nybeck.pdf](#)  
Total Budget: \$190,000.00





Artist: Beth Nybeck  
Proposal: "Rescuer"

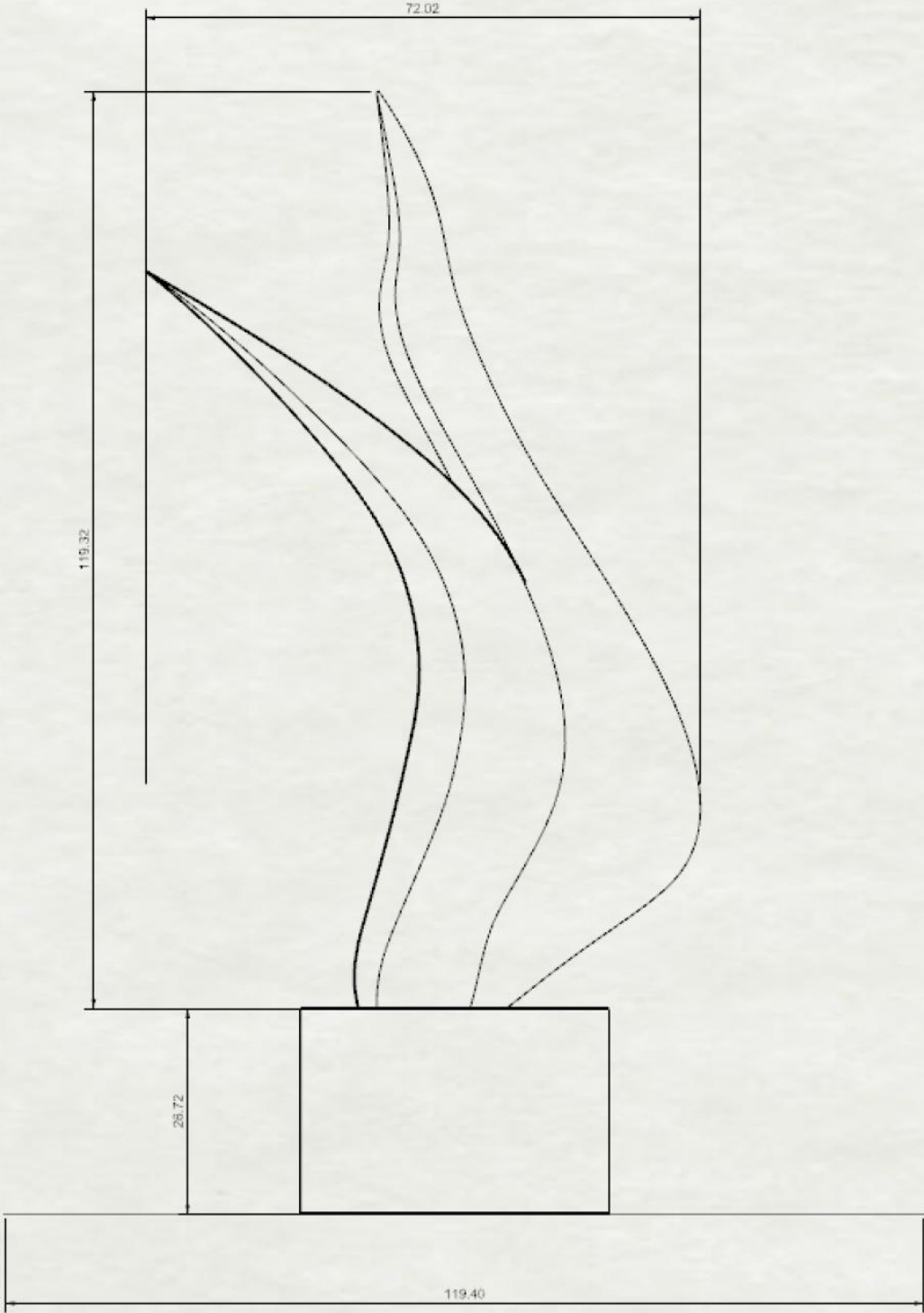



## Denton Fire Station #5 Public Art Proposal

Artist: Beth Nybeck

Proposal: Rescuer

### Narrative:

“Rescuer” is a stainless steel sculpture that embody elements of hope, healing, growth, protection, community and confidence. The City of Denton Firefighters are working hard in the community to provide help during crisis. The work that they do provides the community with security that help will come when they need it most. The sculpture has elements that are reminiscent of organic plant growth and flames.

The sculpture will be perforated to allow light and air to pass through the sculpture. The lighting will be programmed to illuminate in a different pattern or color whenever the first responders are out on a call. The color or pattern will be determined by conversation with the selection panel and firefighters.

There was thoughtful consideration to include humility, integrity, compassion, heroism, selflessness and service within the design.

5. Brodin Studios (Nick Christensen)

Kimball, MN

Project Link: [Denton Proposal 5.pdf](#)

Total Budget: \$125,000.00

**Firefighter Sculpture w / Fire Chief's Lantern (150% Life size)**



**Artist Statement**

At Brodin Studios, we believe public sculpture has the power to carry legacy, embody values, and forge a lasting emotional connection between a community and its heroes. For over 40 years, our studio has been devoted to telling the stories of real people through lifelike bronze sculptures—those who serve, protect, and uplift others in times of need.

Our work is rooted in respect for service and sacrifice. Every piece we create is guided by a deep sense of responsibility: to honor the truth of a uniform, the authenticity of gesture, and the soul of a story. We are drawn to commissions like Denton's because they share our commitment to preserving history through meaningful visual narratives.

Through enduring bronze, we strive to create not just a sculpture, but a landmark—one that honors Denton's firefighters while connecting with all who pass by. At Brodin Studios, we strive for more than art; it's a legacy, made visible.



6. Cesar Henao

Vaison-la-Romaine, France

Project Link: [LUMINOUS WATCH by CESAR HENAO.pdf](#)

Total Budget: \$175,000.00

**Luminous Watch**

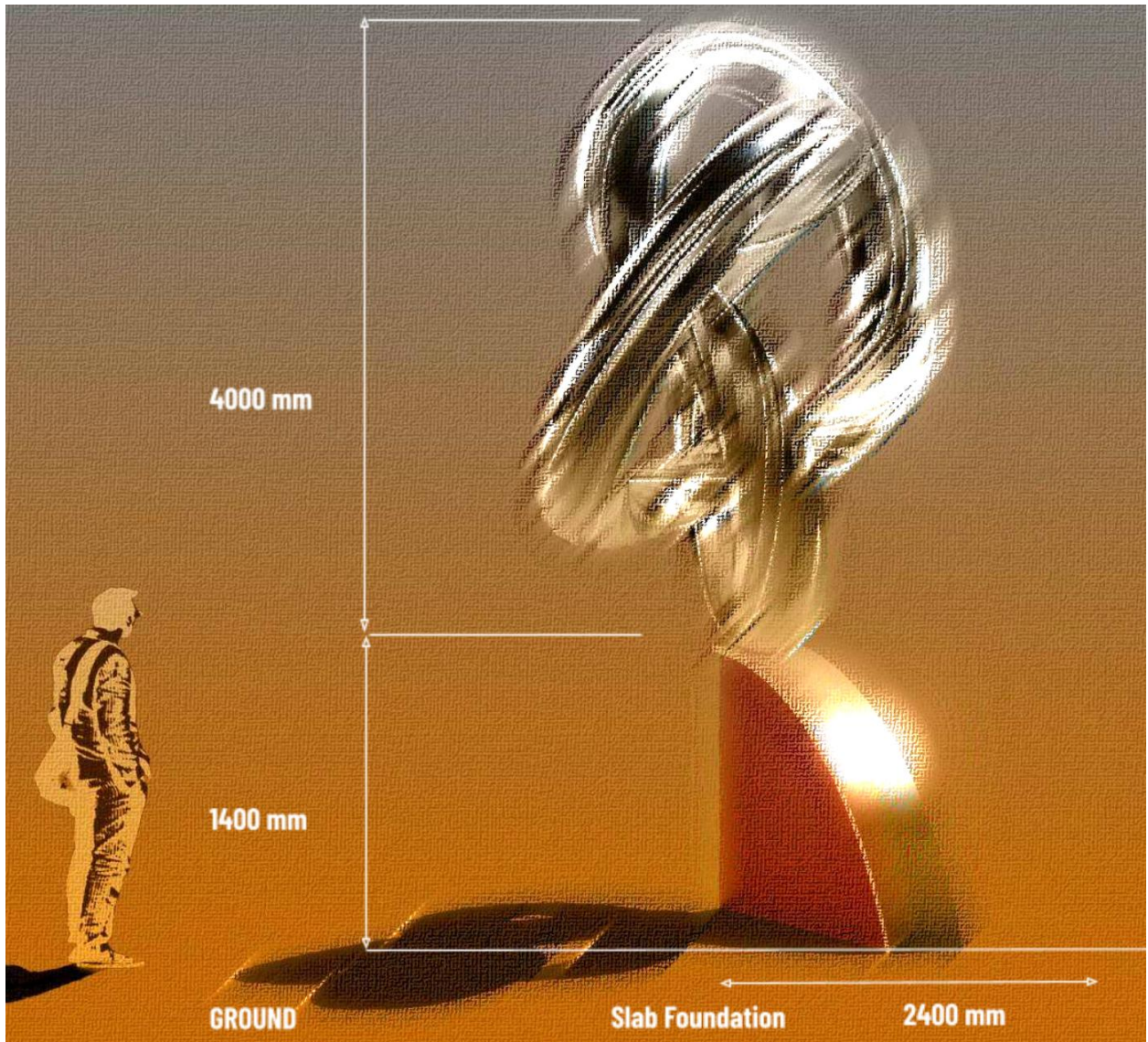



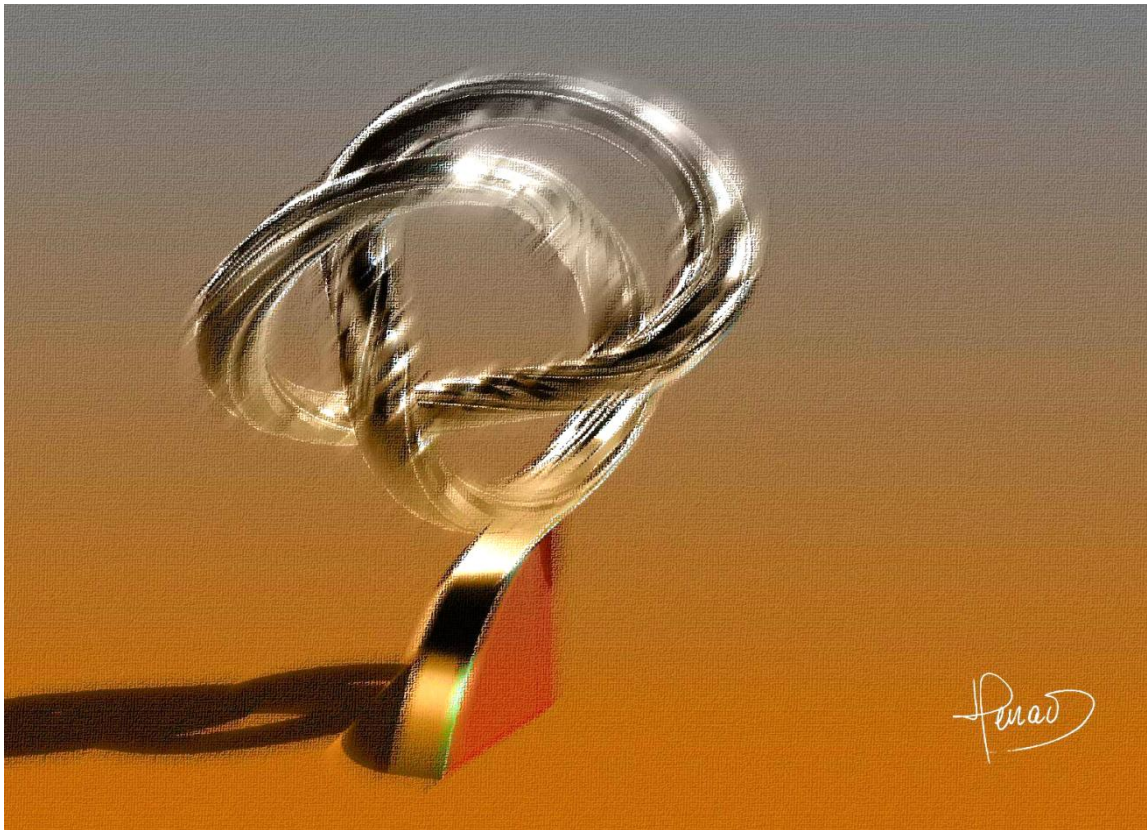



## Artist Statement

I am honored to submit my proposal for Denton City's RFQ with my project, Luminous Watch, a monumental kinetic sculpture that embodies the spirit of resilience and protection, paying tribute to those who safeguard our community. My work has always sought to weave together historical depth and contemporary innovation, and Luminous Watch stands as a natural continuation of that vision.

At its core, Luminous Watch is conceived as a dynamic trefoil whose impossible geometry evokes the continuous, twisting nature of a Möbius strip. Suspended at the edge of a weathered Corten steel arc, the trefoil appears to defy gravity, a delicate equilibrium that captures the tension between stability and fluid motion. This design is not merely an aesthetic choice but a powerful metaphor for the courage and precision required of our first responders; it symbolizes the ongoing battle between chaos and control, a moment of balanced defiance amid danger.

The interplay of high-polish stainless steel with the aged, fire-evoking patina of Corten steel creates a dialogue between past and future. Every kinetic movement and reflective surface has been engineered with precision, marrying advanced technical innovation with a profound commitment to honoring tradition. My extensive background in engineering, material science, and large-scale public art installations ensures that Luminous Watch is not only visually arresting but also structurally sound and fully integrated with its urban context.

Drawing on my previous landmark projects such as Aurea Duo and Tabula Citoyenne, this installation reflects my enduring dedication to creating public art that is both a cultural beacon and an interactive experience. Luminous Watch invites the community to reflect on the delicate balance between risk and safety—a tribute to the transformative spirit of those who work tirelessly to protect us.

I am excited about the opportunity to bring Luminous Watch to Denton City and contribute a lasting symbol of civic pride and perseverance. Thank you for considering my proposal; I look forward to the possibility of enriching Denton's cultural landscape with an artwork that is as innovative as it is timeless.

César Henao

+33 675078256

[cesarh01@gmail.com](mailto:cesarh01@gmail.com)

35 Rue Loucheur

84110 Vaison-la-Romaine



7. Christopher Fennell  
Birmingham, AL  
Proposal Link: [DentonFireStation5.docx](#)  
Total Budget: \$150,000.00  
**Mobius Fire Ladder**

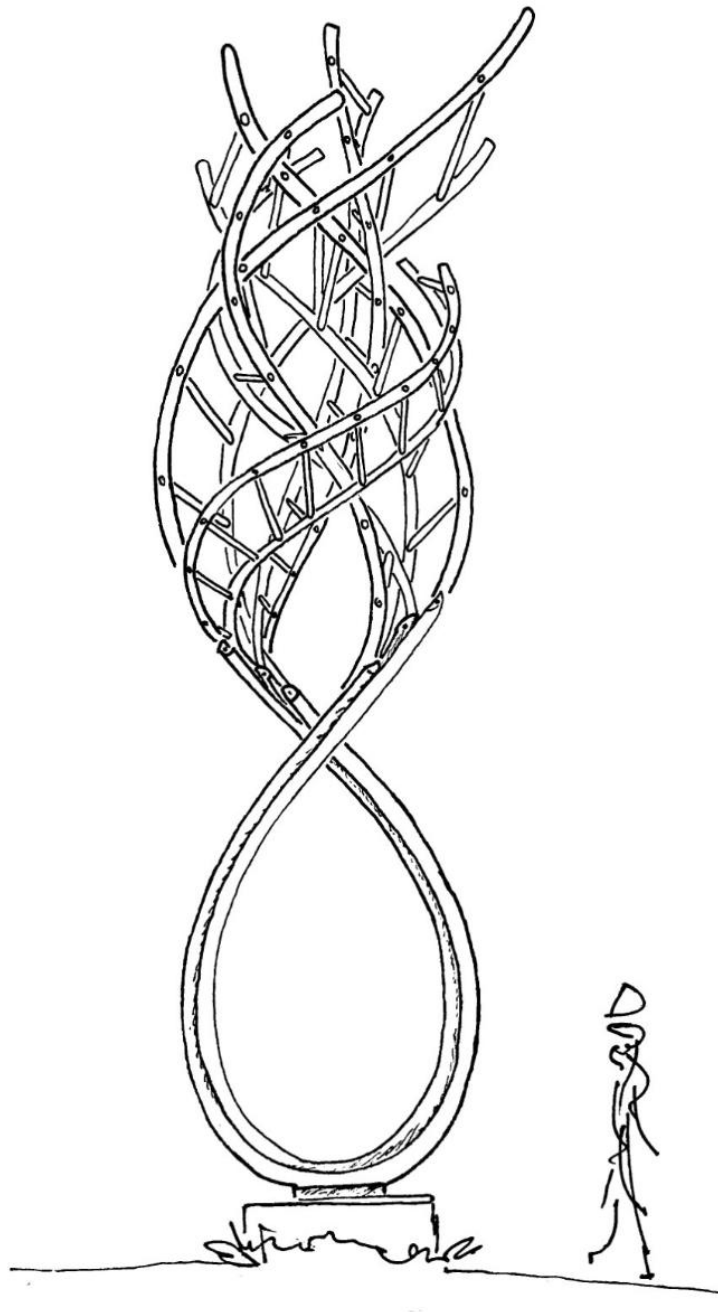

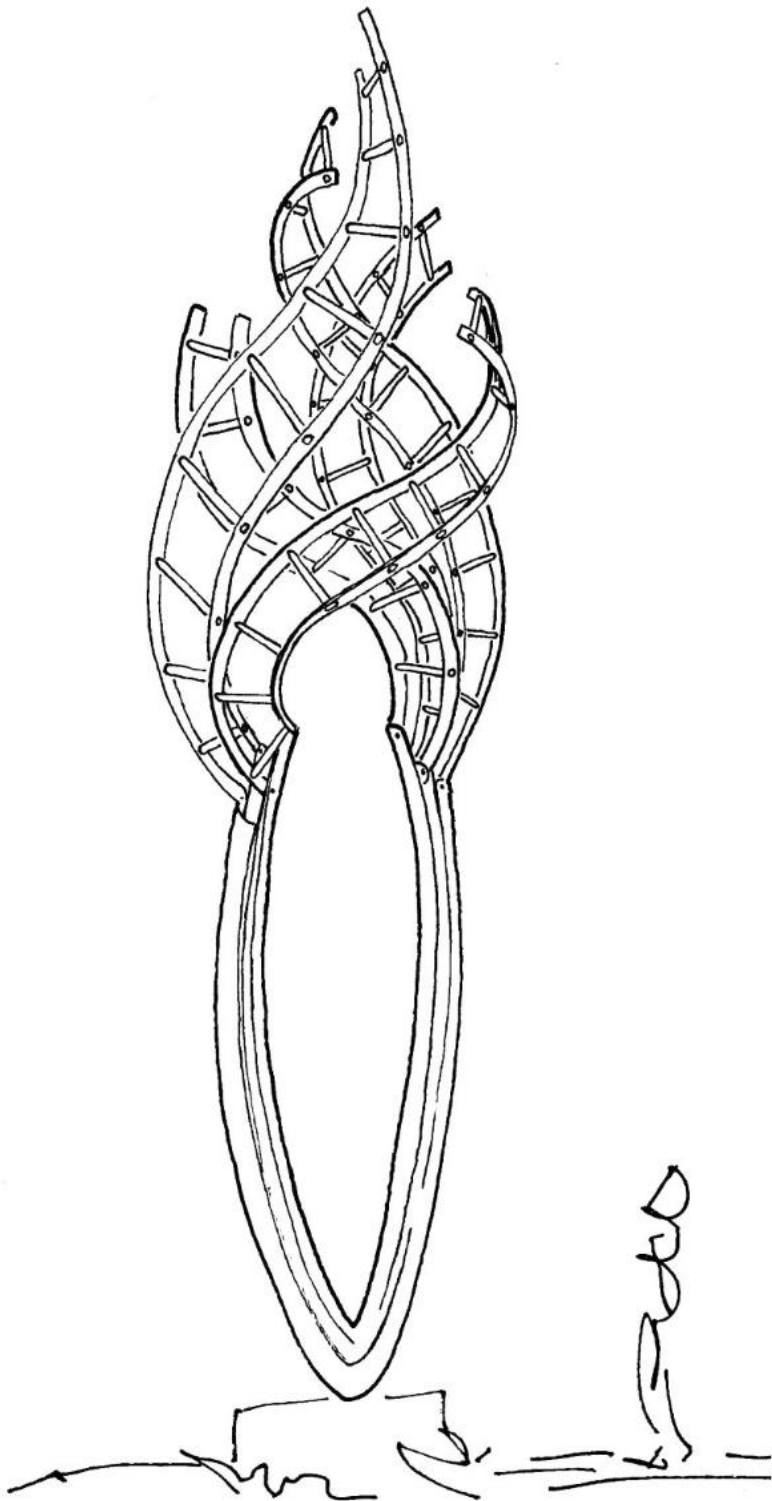



For the Fire Station Number Five, Christopher Fennell proposes sculpting “Mobius Ladder Fire” a 24’ flame made of pipe and decommissioned aluminum fire ladders. The whole sculpture is based off a Mobius strip. In the same way that the artist sculpted a fireball of decommissioned fire ladders for Allen’s Number Five fire station with a base of train rails, as a nod to a historical train robbery that took place there, Denton’s sculpture will have a base of pipe in the shape of water droplet, and a top of fire ladders in the shape of a ball of fire. By opening the top of the water droplet, it works as the base of a Mobius strip, the ladders filling in the top half, creating a figure eight, or the symbol for infinity- commenting on the eternal vigilance of the fire fighters. Red and orange LED floodlights will be placed in the fireball to light it up at night.

8. Sujin Lim – Cloud Study LLC.  
Brooklyn, NY  
Proposal Link: [Fire Station #5 Sujin Lim.pdf](#)  
Total Budget: \$200,000.00  
**Silver Lining Sitting Together**

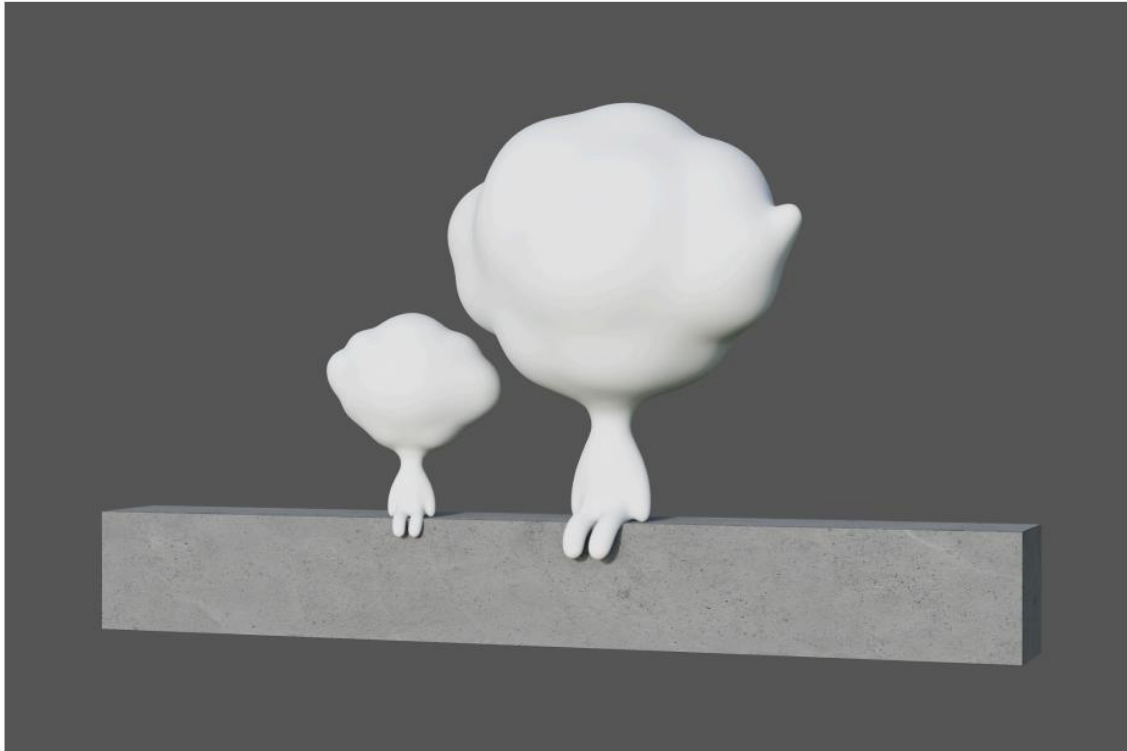

**Size:** approx. 6' x 11' x 3'

**Material:** Mild steel structure and resin cast.

**Proposal Description:** Silver Lining Sitting Together

Silver Lining Sitting Together is a site sculptural installation that embodies the values of protection, solidarity, and quiet resilience. Created specifically for Fire Station 5 in Denton, the work reflects the station's role not only as a center for emergency response but also as a symbol of shared safety and collective care.

The sculpture features two cloud shaped human figures seated on a bench, offering a metaphor for presence, memory, and mutual support. Measuring approximately 6 feet high, 11 feet wide, and 3 feet deep, the work invites both contemplation and interaction. Its cloud headed forms evoke the intangible such as hope, dreams, and remembrance, while the act of sitting together alludes to grounded resilience and community ties.

Fabricated from mild steel and resin cast, the piece balances structural integrity with a soft, luminous surface. The internal structure draws subtle inspiration from the ladder systems and steel frameworks used in traditional firehouse architecture and firefighting tools, quietly

referencing the infrastructure that supports acts of bravery.

Located near the entrance of the station close to flag pole and bike racks, where it can engage with both the public and the station itself, the sculpture serves as a placemaking landmark. Its stillness honors not only the dramatic acts of heroism but the day to day dedication of those who serve. The piece invites viewers to reflect on their own place within the larger story of community care and to sit, perhaps with a stranger, a friend, or a child, and imagine the many lives touched by the work of firefighters.

As a public artist I strive to create works that foster emotional connection and transform public space into shared meaningful experience. Silver Lining Sitting Together does not dramatize heroism. It humanizes it, transforming a fire station plaza into a place for quiet reflection and community presence grounded in Denton's unique civic story.

### Technical Specifications

Silver Lining Sitting Together will be constructed using a welded internal structure of mild steel, providing the necessary strength and stability for long term outdoor installation. The exterior form will be completed using resin cast elements that offer both visual softness and high durability. The sculpture measures approximately 6 feet in height, 11 feet in width, and 3 feet in depth. All surfaces will be sealed with a UV resistant clear coat to protect the finish from sun damage and environmental wear. Anchoring will be secured using below grade concrete footings, engineered to meet local building and wind load codes. All materials are chosen with public interaction and long term weather exposure in mind, ensuring the piece remains structurally sound and visually compelling for decades.

### Maintenance

Routine maintenance for Silver Lining Sitting Together will include annual inspections to check for surface wear, structural integrity, and any signs of corrosion or damage. Cleaning should be performed as needed using a non abrasive cloth and mild soap solution to remove dust, dirt, or environmental residue. Any bird droppings or pollutants should be gently removed as soon as possible to prevent surface staining.

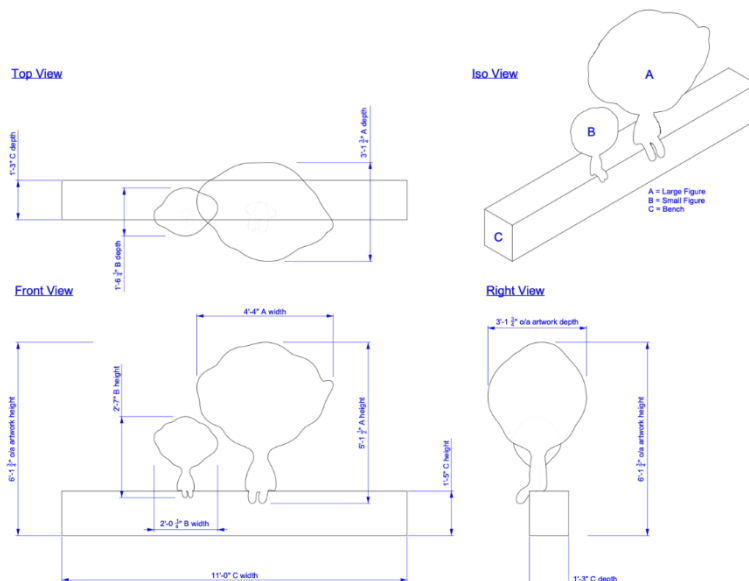

## 9. Daniel Borup Sculptor

Shelley, Idaho

Proposal Link: [Proposal - Daniel Borup.pdf](#)

Total Budget: \$200,000.00

To the Selection Committee

Thank you for this opportunity to submit a proposal for Fire Station #5 and #6. I am excited because I feel my work and expertise can greatly benefit this location and community. I am submitting the same design for both fire stations and would be honored to create this sculpture for either of them. I am a traditional representational sculptor. Bronze will be a great material for this project as it is strong and durable and lasts well in any kind of weather. It is also a classic material for public art and holds up extremely well to viewer interaction

My design depicts two fire fighters in action, creating a dynamic and emotional piece. One spraying the fire hose and the other next on the hose line helps to stabilize. These fire fighters are fully dressed in their turnout gear including the masks. Because of this, they will not be viewed as fire fighters representing any specific gender or ethnicity but rather as courageous fire fighters that the viewer can freely interpret as they wish. These firefighters are moving up stairs which helps to strengthen the sense of action and movement. Visually the hose also guides the viewer through the piece as it wraps around the stairs and directs the viewer to the plaque of the Maltese Cross.

In my proposal this Maltese cross is just a generic one that can be found at many fire departments. I would be happy to make this plaque more specific to Denton with some unique wording and imagery. This plaque is a great opportunity for the committee to help make this piece a memorial specific to Denton. These changes can be decided with help from the committee. This plaque will be two feet tall and wide, making it large enough to be seen from the road from passing cars. This sculpture will be cast in bronze and securely fastened to the concrete pedestal. Lighting will be installed to light it up at night.

The large pedestal, the two figures, the fire hose and the plaque give the piece a monumental impression. All of these elements combined can be quite costly. In order to stay in budget I will be reusing the molds from a piece I have already created for Fire Station #6 in Meridian Idaho. This piece is an edition piece and I have the rights to use this piece again for this memorial in Denton. By reusing these molds I am able to save a little time and money to stay within budget, It also gives you the benefit of being able to see exactly what part of the sculpture will look like when it is installed. I will be changing the helmet patch to be specific to the Denton Fire Department, but all else about this sculpture will remain the same. The second figure will be sculpted to match this first piece stylistically so the entire piece harmonizes.

I have experience with several Public Works as evidenced in my resume. I have also been a finalist for various public art sculptures and have created in-depth proposals with renderings, scale models, and itemized budgets. Working with stakeholders, I have created public art for Libraries, Parks, Roundabouts, Schools, City Halls, Fire Stations, and Police Stations. Each piece has been created on time and within budget.

Aiming to convey the goals of each selection committee, I am willing to hear what preferences they have and adapt my design as necessary. I am eager to use my experience and expertise to create a proposal and ultimately see my sculpture become a reality. Thank you for taking the time to consider my application. I look forward to hearing from you.

Sincerely,



Daniel Borup  
Professional Artist  
daniel@danielborup.com

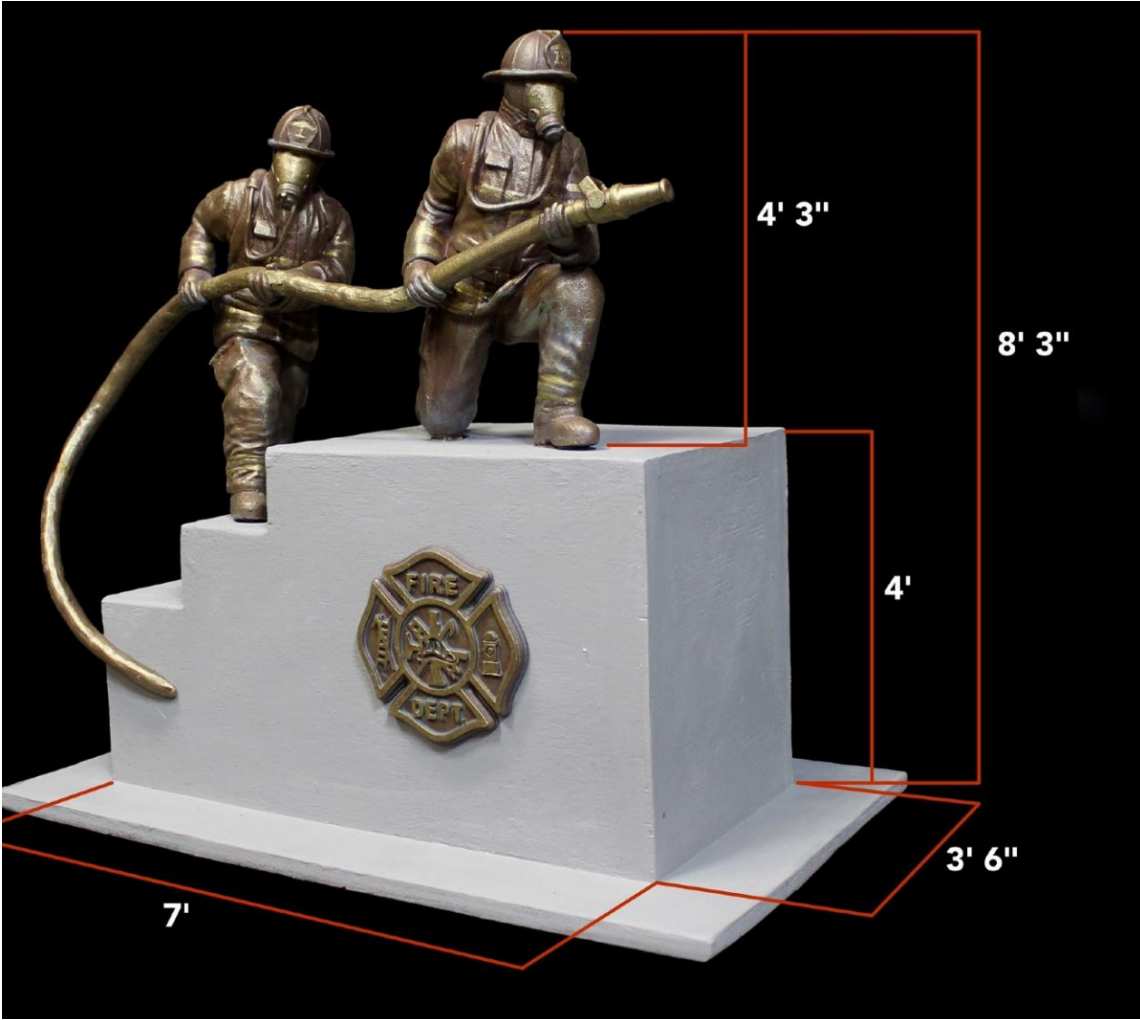



Detail:



10. Denton Maker Center – Loren Jones  
Denton, TX  
Proposal link: [FS5 Submission.pdf](#)  
Total Budget:\$149,200  
**Untitled (firefighter tools)**



# ARTIST STATEMENT

---

“My work celebrates the bravery and dedication of firefighters, those everyday heroes who selflessly risk their lives to protect our communities. Through the medium of public sculpture, I aim to create a tangible and lasting tribute to their unwavering commitment and the essential tools that empower them. Each sculpted element – from the iconic Axe to the helpful Halligan – is carefully rendered to capture the weight, resilience, and purpose inherent in these life-saving instruments. By elevating these objects to a monumental form, I hope to invite viewers to contemplate the profound responsibility these individuals shoulder and to appreciate the vital role they play in safeguarding our lives and well-being. The deliberate placement of the sculpture within the public sphere is crucial. I believe art should be accessible and engaging, fostering a sense of community and prompting reflection. This piece serves as a constant reminder of the courage, sacrifice, and unwavering spirit of our firefighters, inspiring gratitude and respect within the very spaces they so diligently protect. My ultimate goal is to create a powerful and enduring monument that honors their service and ensures their stories are never forgotten.”

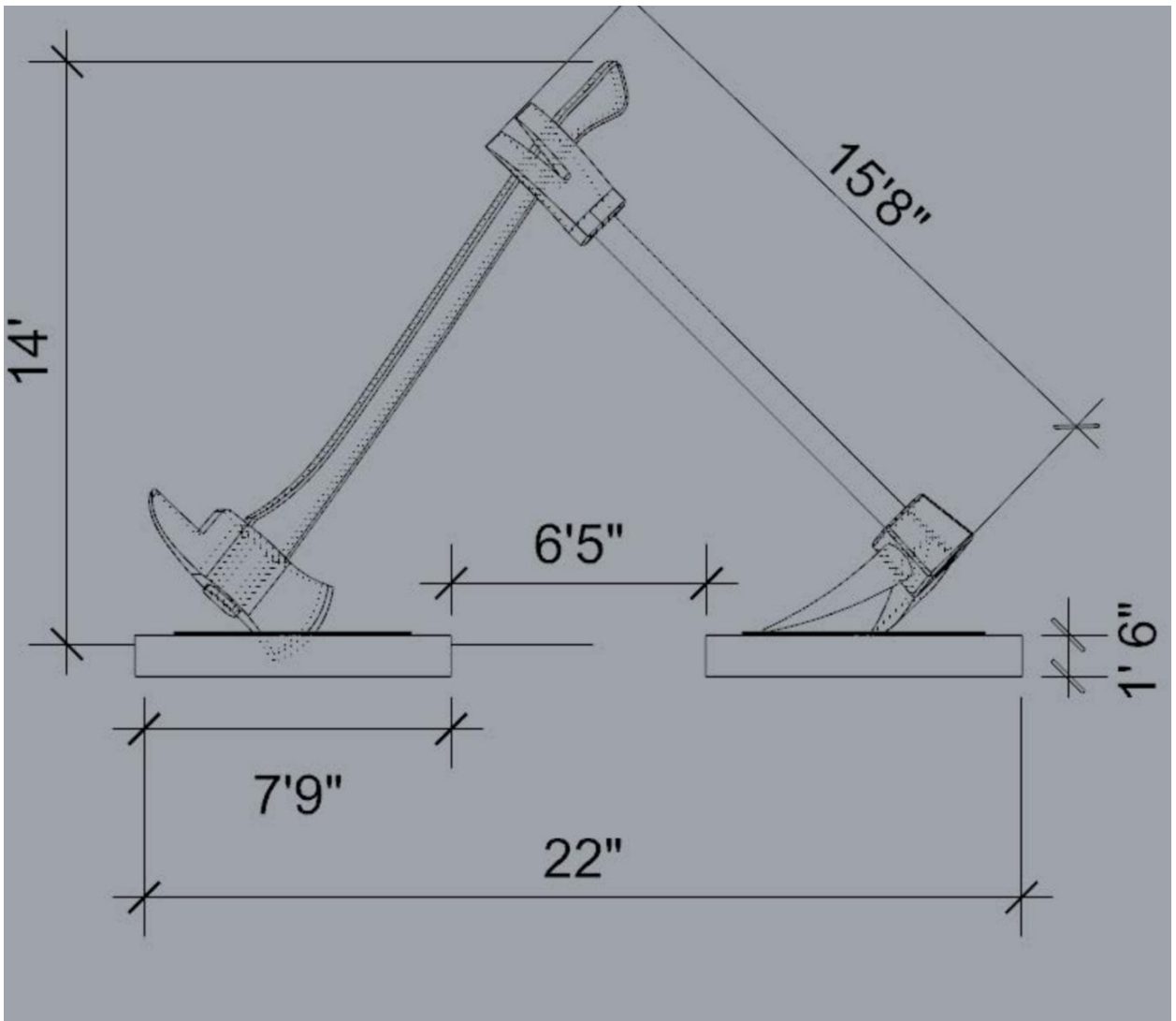



11. Designworks Accessibility Partners (Austin Weishel)  
Argyle, TX

Proposal Link: [Designworks Accessibility Partners](#)

Total Budget: \$238,699.59

**Never Forgotten / Ascending Victor**

## 'NEVER FORGOTTEN'



## "ASCENDING VICTOR"





# AUSTIN WEISHEL

SCULPTOR / RT. FIREFIGHTER / EMT

- Over 20 years of bronze sculpting experience creating Local, State, and National Monuments
- Custom designs with attention to detail
- Hand-sculpted and original artwork, never 3D printed
- Devotion to each work of art
- Customer-focused communication



DETAIL



PASSION



EXPERIENCE

12. Di Bari Innovation Design LLC (Vito Di Bari)  
Miami, FL  
Proposal Link:  
[DB&A Application City of Denton Fire Station 5, Denton, TX.pdf](#)  
Total Budget:\$165,000.00



Beacon of Valor is a tall, cylindrical illuminated column, standing vertically atop a simple concrete base. The column is composed of two complementary layers:

- The outer layer is made of laser-cut, rolled mild steel, painted with industrial-grade direct-to-metal enamel to ensure durability against all weather conditions.
- The inner layer is a white, translucent acrylic panel that diffuses internal lighting.

The artwork's intricate laser-cut designs glow from within, creating a powerful visual narrative that aligns with the City's themes. From top to bottom, the sculpture depicts:

- A firefighter wearing a helmet marked with the number 5, a specific homage to Fire Station 5, looking resolutely forward and framed by radiant beams symbolising valor and bravery.
- A flowing Texas flag, representing the Texas state
- Firefighters in action, working against the flames, while metaphorically standing on the US flag, supporting them and transmitting the enduring spirit of American patriotism
- A firefighter carrying an axe and equipment, reinforcing the tribute to first responders and their daily acts of courage.

#### Color and Lighting Concept:

During daylight hours, the metallic portions of the column will appear in a vivid bright red, alternating with the white of the firefighter figures and other motifs.

At night, internal illumination will introduce a striking red and blue dualism, honoring both the firefighters and the colors of the Texas and U.S. flags. A soft white glow near the base further accentuates the imagery, symbolizing hope and unity.

In keeping with the City's request for an active lighting feature, the sculpture is equipped with a responsive system: upon activation of an emergency call at Fire

Station 5, the interior lighting will shift to an intense red, signaling urgency and respect for the firefighters answering the call.

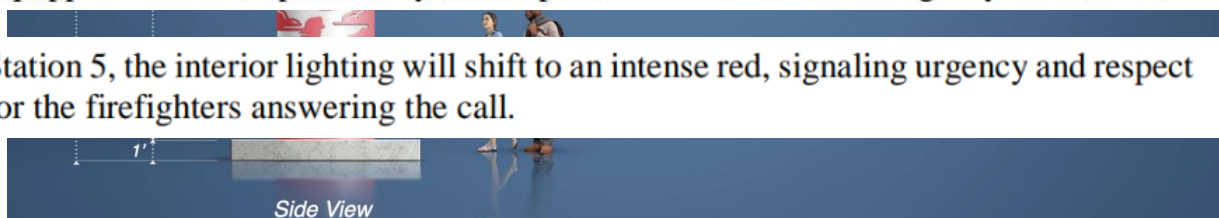



13. Edavant LLC / Big Statues  
Tyler, TX and Salt Lake City, UT



**Offeror:**

**Sheryl Forward**

Endavant LLC

1416 Old Noonday Road

Tyler, TX, 75703

469-434-2653

Texas ID: 32077295080

Socioeconomic Status: Small Business/Texas HUB

Endavant LLC, a Texas-based, HUB-certified, woman-owned business, is proud to partner with Big Statues to support the City of Denton in honoring the bravery and service of its firefighters through the creation and installation of custom bronze firefighter statues.

Endavant LLC specializes in government procurement, project management, and subcontractor coordination. We ensure every aspect of the project—from communication and compliance to logistics and delivery—is handled with professionalism and efficiency.

Big Statues brings over 20 years of experience in designing and fabricating handcrafted bronze sculptures that celebrate public servants and preserve their legacy. Their work can be found in cities, universities, and memorials across the U.S., recognized for its powerful emotion, fine detail, and durability.

Together, Endavant LLC and Big Statues offer the City of Denton a seamless, high-quality partnership dedicated to delivering a public art installation that reflects the pride, courage, and sacrifice of Denton's firefighting heroes.

# STATUE DESIGN

Initial Statue Design and Concept Art



Our design is bold, inspiring, and created to immediately capture attention. With fire elements, the sculpture honors the bravery and sacrifice of all firefighters. We are happy to provide a second design, but please note that concepts normally take weeks to develop, and additional time will be needed to ensure the same level of detail and impact. We will happily modify the final concept to best reflect your vision.

YOUR PROJECT

# BUDGET

Description	Quantity	Price
8' Bronze Firefighter with a Child Statue	1	\$155,900
Large Fire Base	1	\$18,900
Lighting		\$3,500
Installation Estimate		\$7,900
<b>Total Price</b>		<b>\$186,200</b>

Total Statue Cost includes:

- Artist Fee
- Materials Used
- Clay Work
- Artwork/Sketches
- Fabrication
- Mold and Foundry Fee



BIRD'S EYE VIEW:

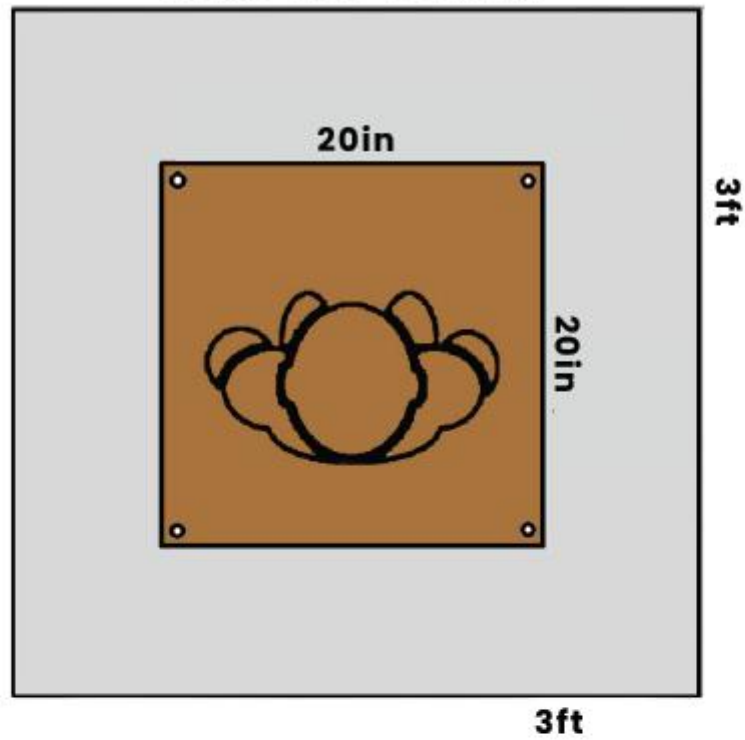

SIDE VIEW:

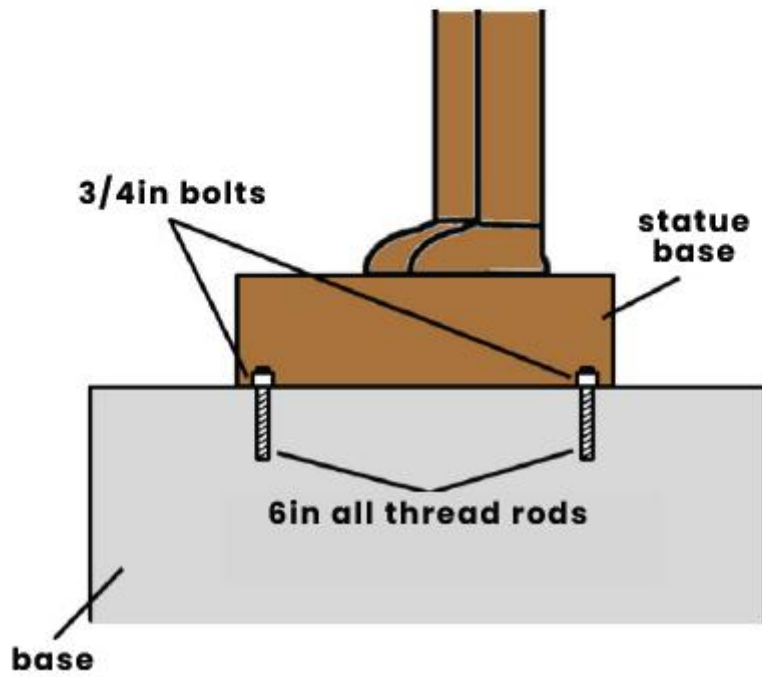

14. Deana Stevens / Go Wild Fabrication  
Azle, TX

## **FIRE STATION #5**

Deana Stevens  
Go Wild Fabrication and Welding, LLC  
6442 Nine Mile Bridge Rd.  
Fort Worth, TX 76135  
April 8, 2025

Parks and Recreation Department  
901 Texas St.  
Denton, Texas 76209

Parks and Recreation Department,

As a diverse artistic team and co-owners of Go Wild Fabrication and Welding, LLC, we are excited to submit our proposal for the Fire Station #5 public art opportunity. With a background that blends large-scale sculpture, graphic design, and structural steel fabrication, we create work that honors community, resilience, and craftsmanship—values that align deeply with the spirit of fire service.

We were so excited about this opportunity that we are submitting three different design ideas for consideration. Each concept reflects our creative vision and commitment to celebrating the bravery of first responders and the strength of the community they serve. We wanted to provide a range of options to inspire the space and ensure a meaningful connection to the Fire Station #5 location.

Why choose us? Because we don't just design—we fabricate and install the artwork ourselves. Go Wild Fabrication and Welding, LLC is a fully equipped shop with all the machinery and tools necessary to build the sculpture in-house. We even have a structural engineer on staff, which allows us to handle engineering needs quickly and make adjustments on the fly. By keeping the entire process under one roof, we eliminate the delays and complications that often come from outsourcing to multiple vendors—saving time, cost, and stress.

Thank you for considering our proposal. We have included all required materials, including visuals of past work and a detailed project concept. We would be honored to contribute to this meaningful space and welcome the opportunity to further discuss our ideas with your team.

Sincerely,  
Deana Stevens  
Go Wild Fabrication and Welding, LLC  
(619) 244-7576  
deana@gowildfabrication.com  
www.gowildfabrication.com

TITLE: BRAVERY IN ACTION



**SPECIFICATIONS:**

**MATERIALS:**

WELDED METALS- MILD STEEL, STAINLESS STEEL,  
CORTEN RUSTED STEEL

**PAINT FINISHES:**

NO PAINT NEEDED. THE CORTEN WILL RUST NATURALLY  
AND IS LONG LASTING.

SCULPTURE WILL BE CONSTRUCTED OF A STEEL  
FRAME WITH WELDED/FORMED CORTEN STEEL ON THE SURFACE.

**PROPOSED SCHEDULE:**

4 MONTHS AFTER FINAL  
DESIGN AND ENGINEERING/APPROVALS

**MAINTENANCE:**

CORTEN STEEL DOES NOT REQUIRE  
MAINTENANCE AS IS MEANT TO RUST  
NATURALLY.  
THERE IS NO PROPOSED MAINTENANCE  
SCHEDULE FOR THIS SCULPTURE.

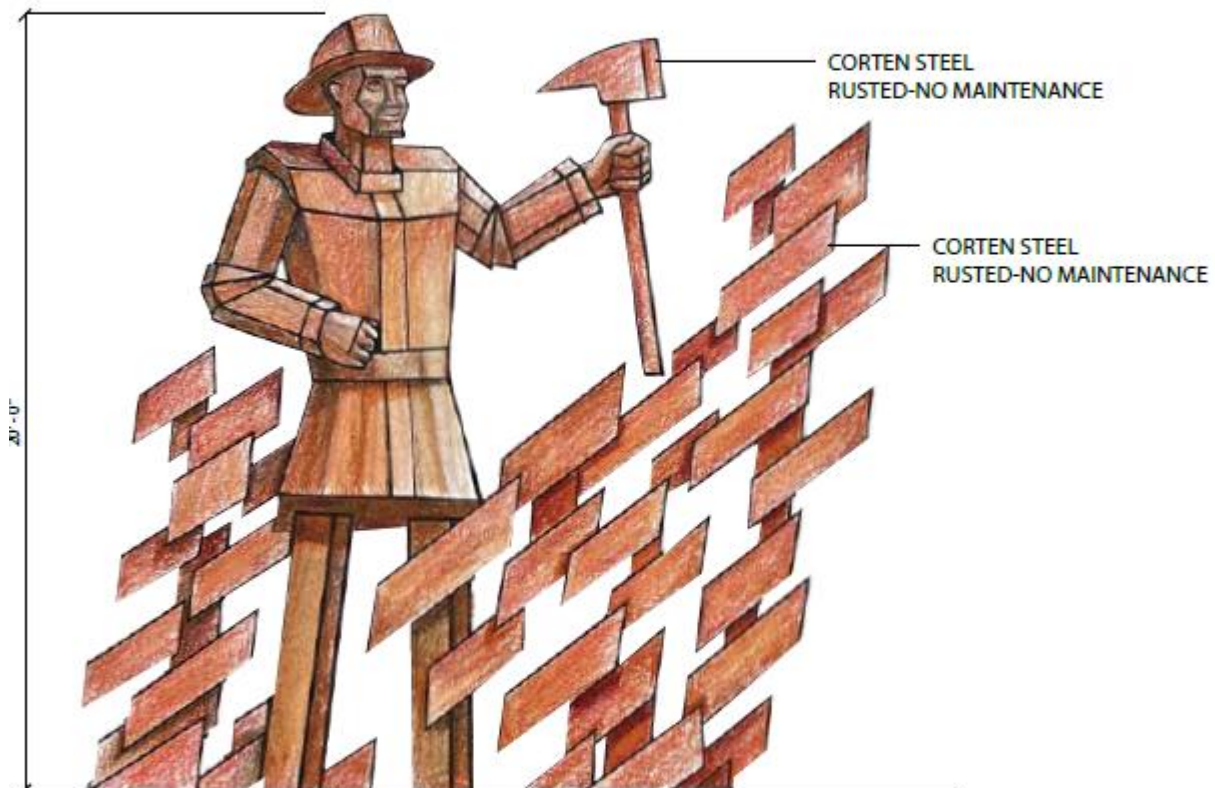

**COST BREAKDOWN: \$197,000**

ENGINEERING: \$10,000

UNDERGROUND POWER AND LIGHTING: \$12,000

PAVING & CONCRETE FOOTINGS: \$20,000

METAL: \$45,000

EQUIPMENT RENTALS: \$5,000

LABOR/CONSTRUCTION: \$105,000

**NOTE: LIGHTING WILL ALLOW FOR COLORED LIGHTS TO  
DISPLAY WHEN EMERGENCY CREWS ARE DEPLOYED. THE  
LIGHTS WILL REFLECT OFF THE METAL SURFACES, CREATING  
A DYNAMIC INTERPLAY OF HIGHLIGHTS AND SHADOWS THAT  
ENHANCES THE SCULPTURE'S DEPTH AND MOVEMENT AS PEOPLE  
DRIVE/WALK PAST. IMAGINE HOW BEAUTIFUL THE CASTED SHADOWS  
WILL BE!**



FIRE STATION - 5  
ART LOCATION PLAN



ELEVATION VIEW - NTS

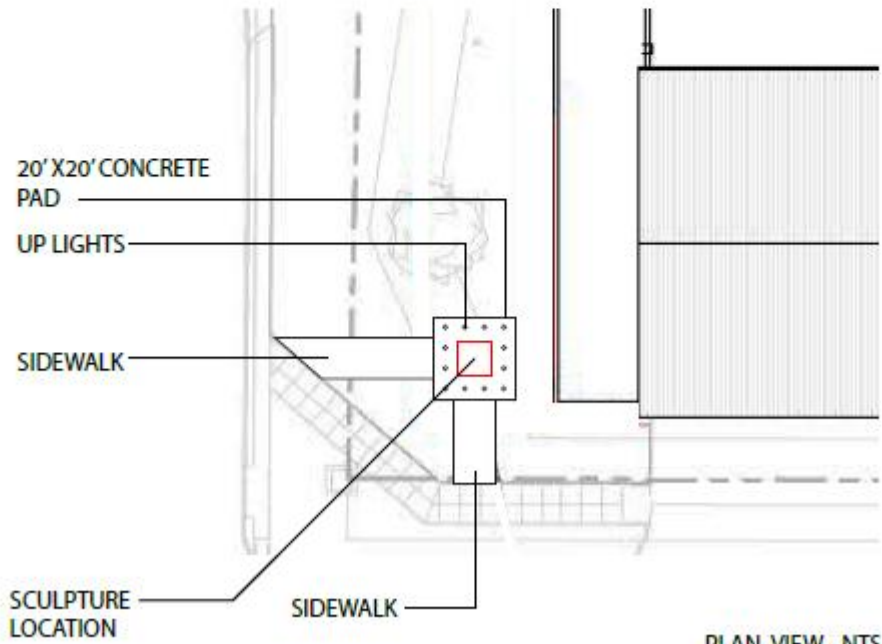

PLAN VIEW - NTS



TITLE: HANDS OF VALOR

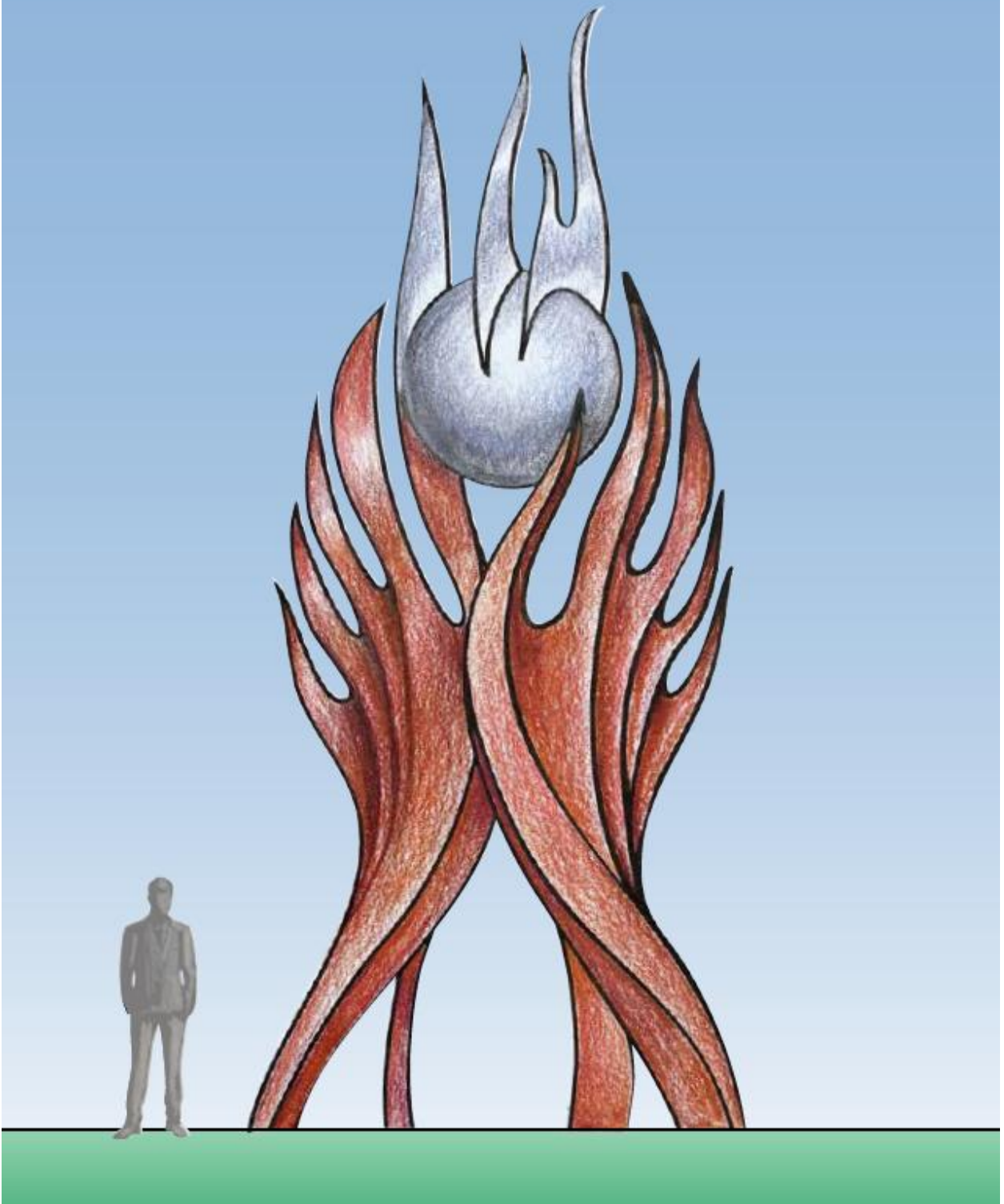

**SPECIFICATIONS:**

**MATERIALS:**

WELDED METALS- MILD STEEL, STAINLESS STEEL,  
CORTEN RUSTED STEEL

**PAINT FINISHES:**

POLYURETHANE AUTOMOTIVE PAINT  
FINISHES & CLEAR COATS (ONLY WHERE NEEDED)

SCULPTURE WILL BE CONSTRUCTED OF A STEEL  
FRAME WITH WELDED/FORMED STAINLESS & CORTEN STEEL ON THE SURFACE.

**PROPOSED SCHEDULE:**

4 MONTHS AFTER FINAL  
DESIGN AND ENGINEERING/APPROVALS

**MAINTENANCE:**

CORTEN STEEL DOES NOT REQUIRE  
MAINTENANCE AS IS MEANT TO RUST  
NATURALLY.

THERE IS NO PROPOSED MAINTENANCE  
SCHEDULE FOR THE CORTEN PORTION  
OF THIS SCULPTURE.

PAINTED STEEL/CLEARCOAT WILL BE  
PAINTED WITH AUTO PAINT WHICH  
SHOULD LAST UPWARD TOWARDS  
20 YEARS. IF NEEDED-WILL MASK OFF  
AND REPAINT IN THE FUTURE.

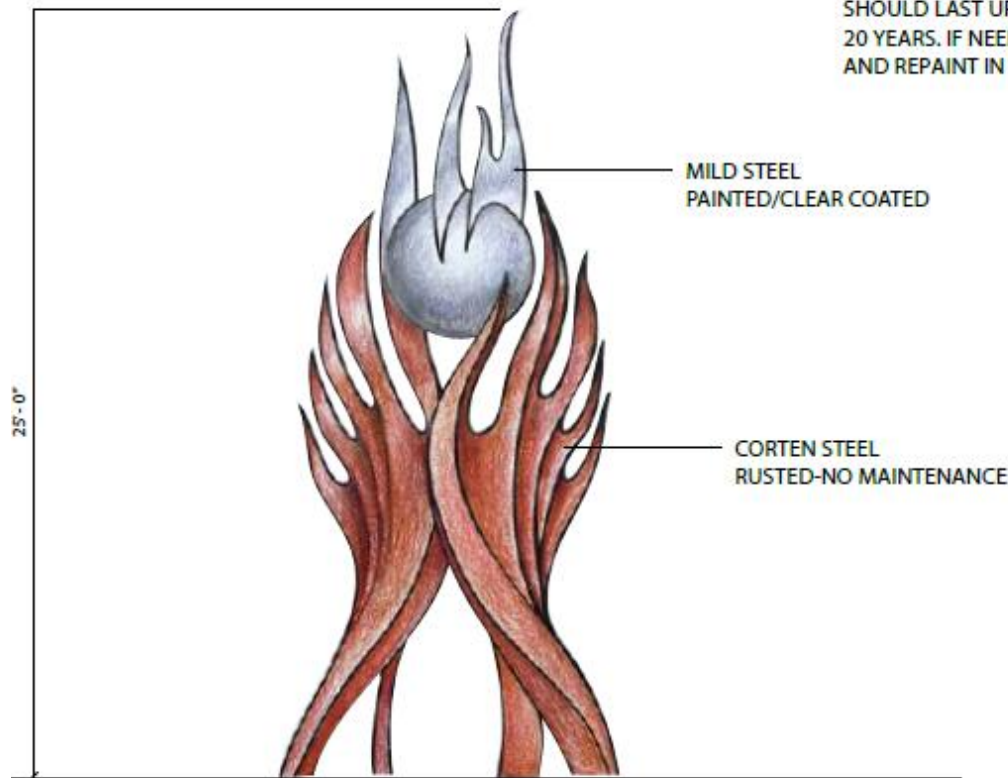

**COST BREAKDOWN: \$182,000**

ENGINEERING: \$10,000

UNDERGROUND POWER AND LIGHTING: \$12,000

PAVING & CONCRETE FOOTINGS: \$20,000

METAL: \$28,500

EQUIPMENT RENTALS: \$5,000

LABOR/CONSTRUCTION: \$107,000

**NOTE: LIGHTING WILL ALLOW FOR COLORED LIGHTS TO  
DISPLAY WHEN EMERGENCY CREWS ARE DEPLOYED. THE  
LIGHTS WILL REFLECT OFF THE METAL SURFACES, CREATING  
A DYNAMIC INTERPLAY OF HIGHLIGHTS AND SHADOWS THAT  
ENHANCES THE SCULPTURE'S DEPTH AND MOVEMENT AS PEOPLE  
DRIVE/WALK PAST.**

FIRE STATION - 5  
ART LOCATION PLAN



ELEVATION VIEW - NTS

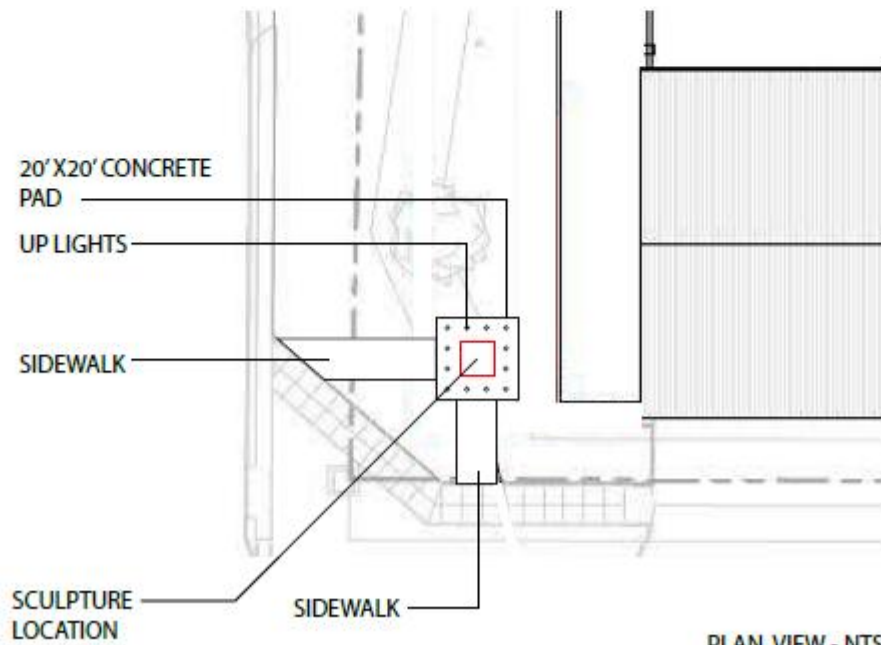

PLAN VIEW - NTS



TITLE: STRONGER TOGETHER



**SPECIFICATIONS:**

**MATERIALS:**

WELDED METALS- MILD STEEL, STAINLESS STEEL,  
CORTEN RUSTED STEEL

**PAINT FINISHES:**

POLYURETHANE AUTOMOTIVE PAINT  
FINISHES & CLEAR COATS (ONLY WHERE NEEDED)

SCULPTURE WILL BE CONSTRUCTED OF A STEEL  
FRAME WITH WELDED/FORMED STEEL ON THE SURFACE.

**PROPOSED SCHEDULE:**

4 MONTHS AFTER FINAL  
DESIGN AND ENGINEERING/APPROVALS

**MAINTENANCE:**

CORTEN STEEL DOES NOT REQUIRE  
MAINTENANCE AS IS MEANT TO RUST  
NATURALLY.

THERE IS NO PROPOSED MAINTENANCE  
SCHEDULE FOR THE CORTEN PORTION  
OF THIS SCULPTURE.

PAINTED STEEL/CLEARCOAT WILL BE  
PAINTED WITH AUTO PAINT WHICH  
SHOULD LAST UPWARD TOWARDS  
20 YEARS. IF NEEDED-WILL MASK OFF  
AND REPAINT IN THE FUTURE.

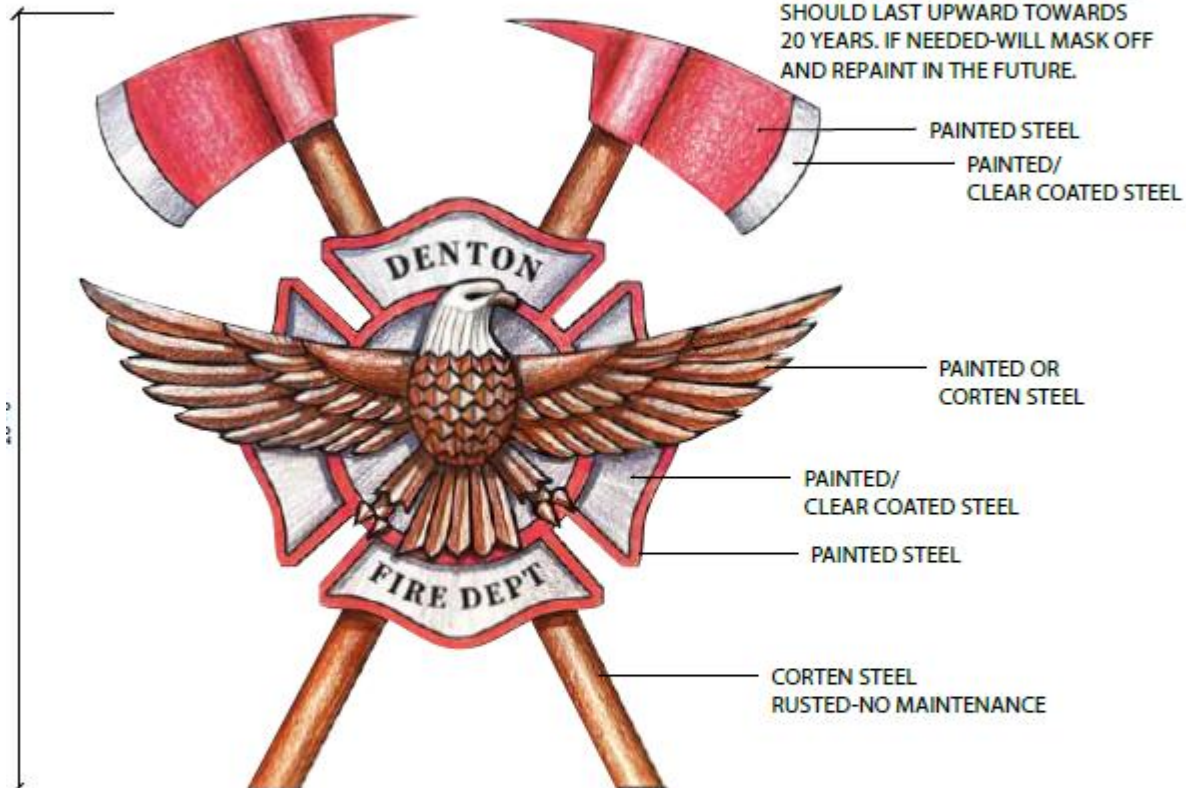

**COST BREAKDOWN: \$157,000**

ENGINEERING: \$10,000

UNDERGROUND POWER AND LIGHTING: \$12,000

PAVING & CONCRETE FOOTINGS: \$20,000

METAL: \$30,000

EQUIPMENT RENTALS: \$5,000

LABOR/CONSTRUCTION: \$80,000

**NOTE: LIGHTING WILL ALLOW FOR COLORED LIGHTS TO  
DISPLAY WHEN EMERGENCY CREWS ARE DEPLOYED. THE  
LIGHTS WILL REFLECT OFF THE METAL SURFACES, CREATING  
A DYNAMIC INTERPLAY OF HIGHLIGHTS AND SHADOWS THAT  
ENHANCES THE SCULPTURE'S DEPTH AND MOVEMENT AS PEOPLE  
DRIVE/WALK PAST.**



FIRE STATION - 5  
ART LOCATION PLAN



ELEVATION VIEW - NTS

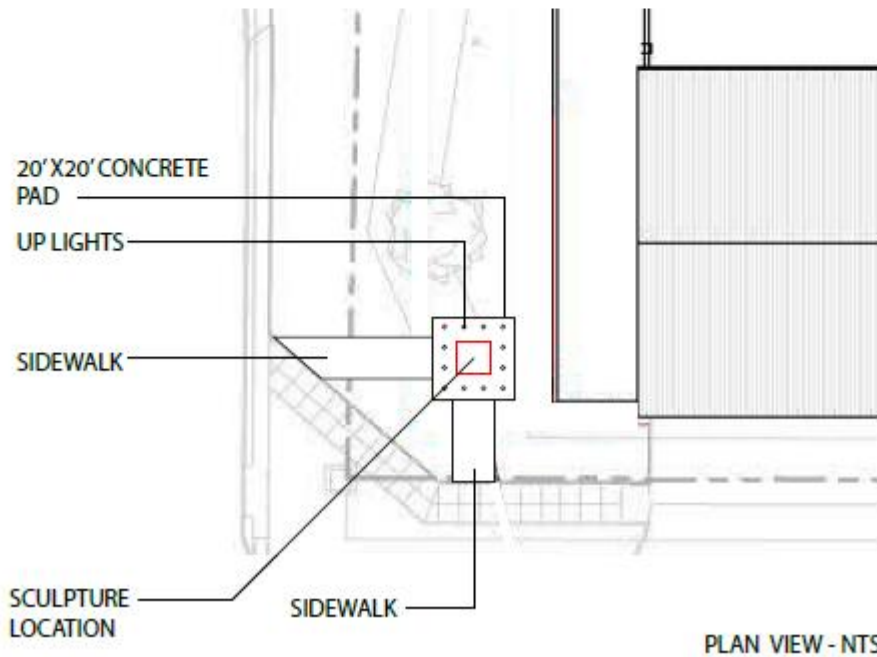

Deana Stevens  
Artist/Graphic Designer/Public Artist  
7205 Hickey Rd.  
Azle, TX 76020  
deana@gowildfabrication.com  
619-244-7576

Creativity has always been at the heart of my life. From my earliest memories, I was captivated by the world my father built—one filled with imagination, craftsmanship, and endless possibilities. He taught me how to sculpt figures in clay, sparking a love for creating that led me to continue working with clay through college, selling my personal creations on eBay to make extra cash.

After high school, I worked at a sign fabrication business where I had the opportunity to work on a wide range of projects. I hand-painted and hand-sculpted signs for Disneyland, helping to create some of the largest and most iconic themed signs, including Tarzan, Pirates of the Caribbean, and the enormous carousel signs. My experience spanned projects as small as ADA signage to large-scale installations for places like Legoland.

That hands-on experience with fabrication and large-scale design fueled my passion for immersive art. This led to my selection as the youngest artist for the Port of San Diego's Urban Tree project at 23, where I created my first large-scale public sculpture. After that, my dad and I went on to design and create sculptures together until I moved to Texas. Even then, he came out to assist me when I was awarded the job for the Hill School Library, making it a truly special project.

I have always had a childlike imagination, and I strive to create art that sparks the same sense of wonder in my own children. There is something special about how a child sees art—unfiltered, full of curiosity, and open to endless possibilities. That perspective has deeply influenced my approach to sculpture, pushing me to craft pieces that invite imagination and interaction.

My career has spanned roles in graphic design, sign fabrication, and even the creation of a magical dream library—each project reinforcing my belief that art should be immersive, transformative, and enduring.

Now, as project manager at my husband's welding shop, I am excited to merge my artistic vision with the strength of structural steel fabrication. Even more exciting, my dad, my husband, and I plan to work together on the firehouse sculptures—a true dream team. I am also passionate about sharing my work locally, hoping to inspire my children and others to embrace creativity. My goal is to create large-scale sculptures that are both visually striking and built to last, leaving a meaningful impact on the spaces they inhabit.

15. Art Garcia / Graphic Content  
Dallas, TX  
Total Budget: \$200,000

Art Garcia

DESIGN PROPOSAL

**Concept:** The working concept of the artwork is to identify five Texas firefighting achievements, specifically those relating to fire suppression in North Texas. This proposal seeks to showcase a timeline with fire fighter's working gloves. The public will learn 1857 was the founding of the City of Denton, 1935 the first fire hydrant installed, grass fire technology in 1975 and the modern apparatus in 1999.

**Description:** The installation utilizes five relief metal panels in custom laser-cutout metal providing low maintenance materials. Relief red work gloves grip a hose with key dates, relief working hands and icons identifying those milestones. Fabricated in metal with a custom anchor system approved by a Texas Certified structural engineer and mounted on the wall surface. Each panel is back lit by a lighting system with a red vertical light traveling behind the perforated gray panels while firefighters are on call. The individual objects are powder coated in hues used in firefighting equipment and PPE. While durable, the artwork will also be easily reproduced and repaired in an event of damage due to outside forces. The artwork is viewable from south and west directions at a location previously identified by the city to consider artwork placement.

The design process is completed in three phases: design, fabrication and installation. The design phase considers all aspects of the sculptures aesthetic approach as it relates to the public art realm. The fabrication phase will overlap the design phase in consideration of anchoring, fastening and welding in addition to the application of pigment. In this case, powder coating for durability. Installation occurs with two to three sight visits to confirm the proper footings or pads are accurately prepared to accommodate the sculpture(s). Installation may occur with an a crew of 3 of 5 or outside contractor.

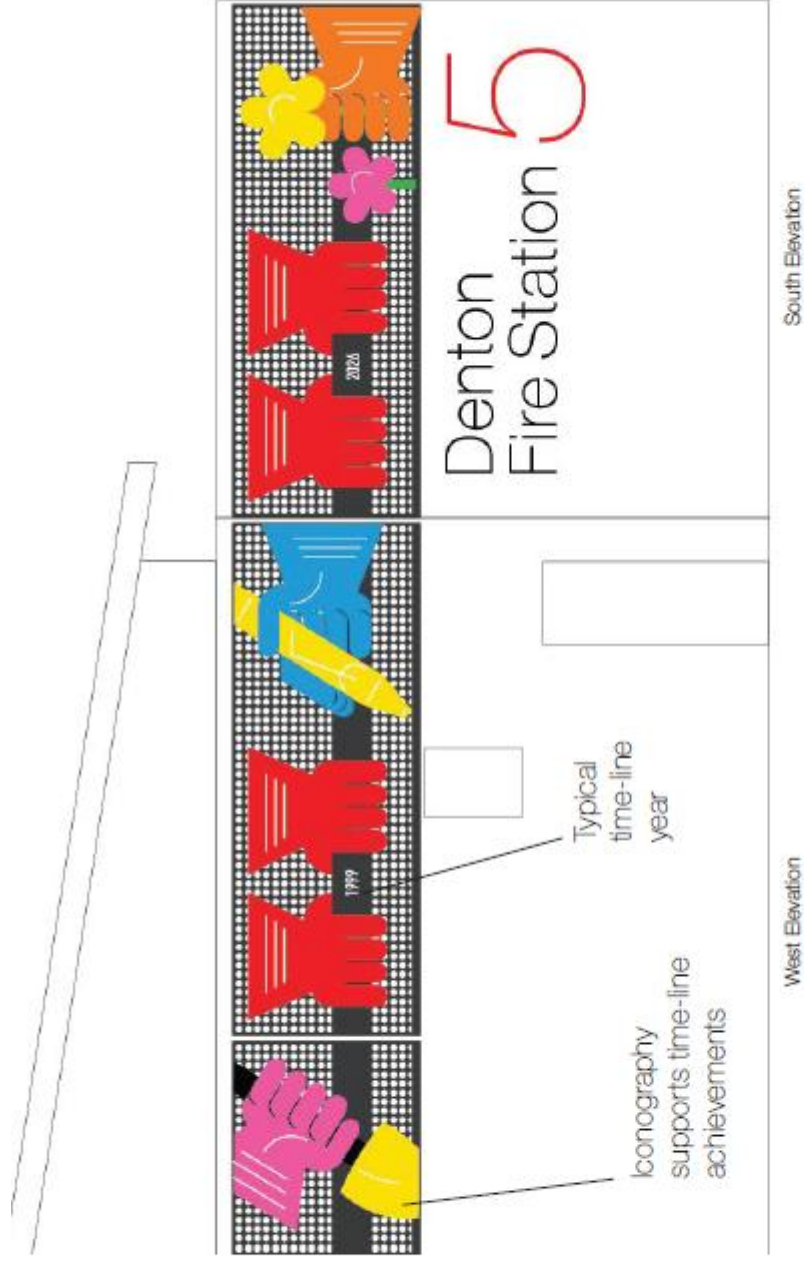

**Texas Firefighting Achievements**

A permanent installation this metal wall relief sculpture includes a time-line and back lit white, 2026 is a five petal flower indicating the fire fighters care for community.

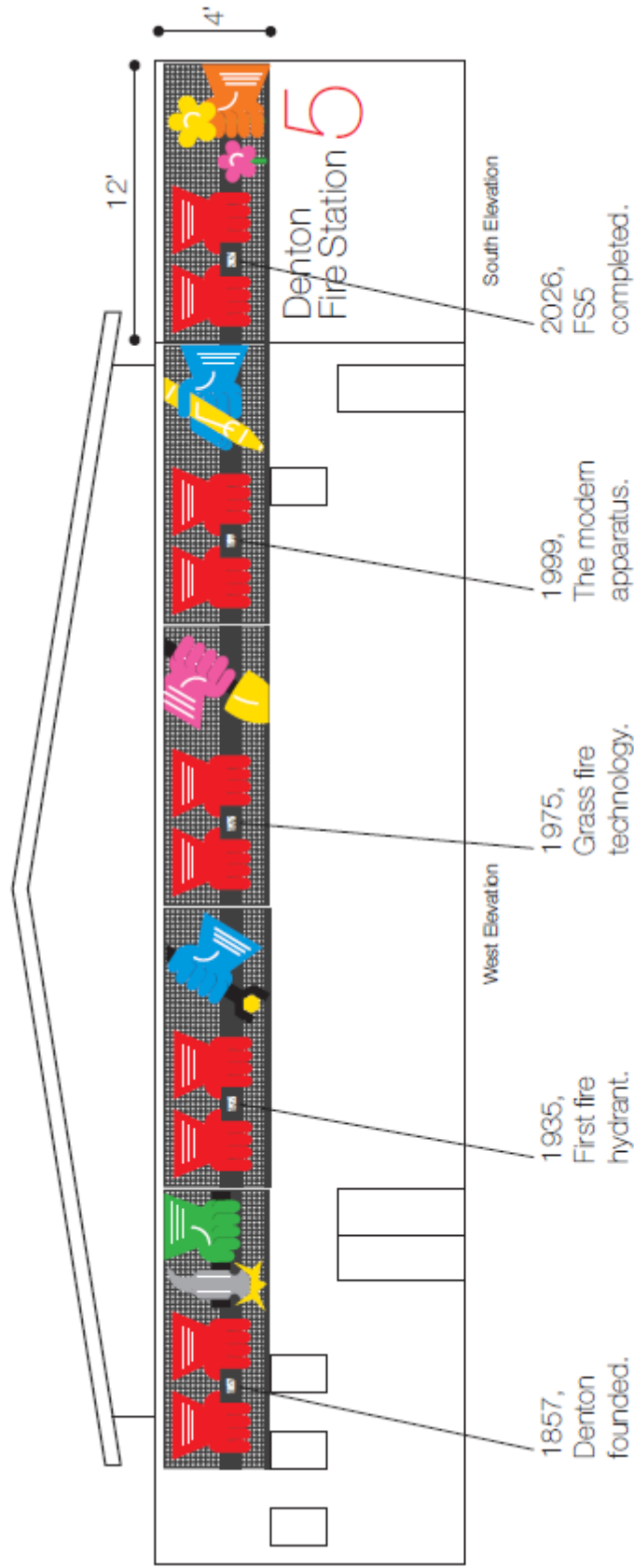

### Texas Firefighting Achievements

A permanent installation, the artwork fosters community engagement and interaction with five Texas fire fighting achievements through a historic timeline.



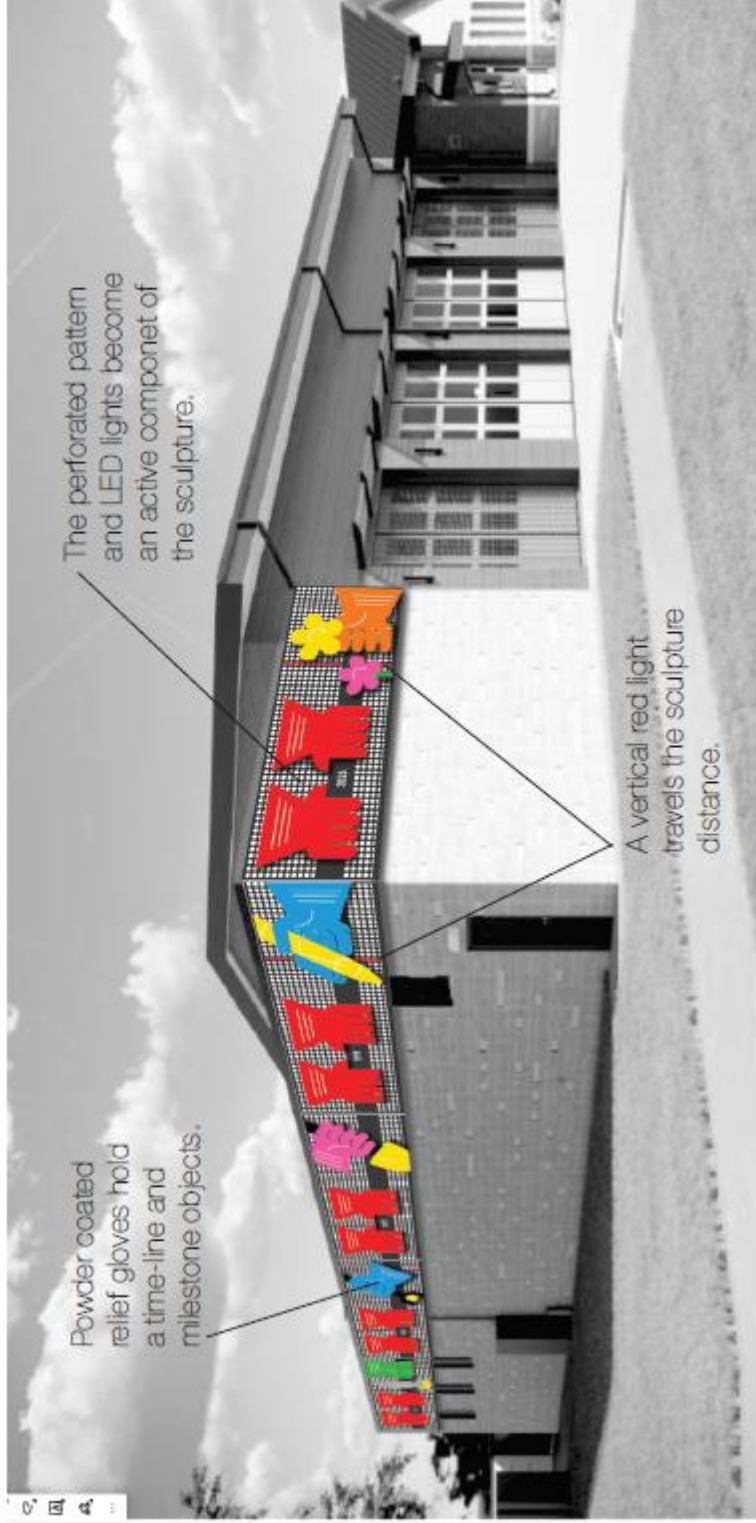

Southwest Elevation

**Texas Firefighting Achievements**

Powder coated metal objects are low maintenance with a UV coating. LED back lighting is programmed to indicate an emergency call.

## Budget Outline

The artwork will utilize metal, plasma cut, powder coating. Properly constructed, the installation will require very little maintenance, though its appearance can be preserved, and the lifetime of the coating extended by periodic cleaning and waxing.

<u>Project Coordination</u>	<u>Schedule</u>	<u>Fee</u>
<b>Artist's fee</b>		
Preliminary design (artist's fee in preliminary design contract TBD)		\$ 5,000.00
Final design (artist's fee in final design/commission contract TBD)		\$ 5,000.00
<b>Consultants/Other People-Related Costs</b>		
Engineering (structural)	60 days	\$ 10,000.00
Photographer	3 days	\$ 2,400.00
Computer art preparation,	60 days	\$ 8,000.00
Model, digital maquette	20 days	\$ 5,000.00
Fabrication	110 days	\$ 23,500.00
<b>Transportation</b>		
Travel	3 days	\$ 1,000.00
Shipping of materials to fabrication site	15 days	\$ 6,000.00
Shipping of artwork to installation site	5 days	\$ 3,000.00
<b>Materials</b>		
Metal	8 days	\$ 20,000.00
Fasteners and anchors	10 days	\$ 1,500.00
Painting/powder coating	30 days	\$ 20,000.00
<b>Site Preparation</b>		
Site survey/meetings	5 days	\$ 2,000.00
Installation Labor/Equipment	20 days	\$ 30,000.00
Rentals (lifts, special equipment/materials, studio supplies, etc.)	3 days	\$ 6,000.00
Permits	10 days	\$ 2,000.00
Installation Labor	5 days	\$ 25,000.00
<b>Insurance Coverage</b>		
Loss/theft/damage (supplies and fabrication parts prior to shipping and during shipping-inland marine)		\$ 1,000.00
General liability (self, subcontractors, assistants)		\$ 600.00
Workers' compensation for assistants		\$ 1,000.00
Automobile and any special insurance riders		\$ 2,000.00
<b>Contingency (10%)</b>		<b>\$ 20,000.00</b>
<b>Total Budget</b>	<b>366 days</b>	<b>\$ 200,000.00</b>

Art Garcia, Graphic Content, Inc. agrees to the scope of work and budget of \$200,000. Acknowledges and agrees to comply with all applicable federal, state and local laws, regulations and grant requirements associated with NEA funding.

The estimated completion date of 10/2026 is achievable. An additional six-month contingency is an adequate timeframe for undetermined factors like weather, material availability, engineering, construction, and city permit approvals.

**Routine Maintenance** The artwork will utilize metal, plasma cut, powder coating. Properly constructed, the installation will require very little maintenance, though its appearance can be preserved, and the lifetime of the coating extended by periodic cleaning and waxing.

---

**Artist:** Art Garcia—Graphic Content, Inc.  
**Title of Work:** Texas Firefighting  
**Date Created/Completed:** October 2026  
**Dimensions:** 5' X 50'  
**Medium:** Steel, powder coating, lucite  
**Location:** Denton Fire Station 5

#### MAINTENANCE/CONSERVATION INSTRUCTIONS

•Provide instructions regarding the methods and frequency of maintenance for the artwork (with observations regarding permanency/durability of materials and techniques): **Visual maintenance inspections should be conducted bi-annually for corrosion or vandalism damage. Once damage has been identified refer to installation and cleaning procedures.**

•Routine maintenance (e.g., removal of dust, dirt; maintenance of protective surfaces; tightening, adjusting, oiling; etc.): **To remove dust, broadcast a spray of water using standard water pressure (between 50-100 psi) on a monthly basis. Constant pressure in one given area should be avoided at all times. Wipe completely dry with soft clothe. DO NOT clean with harsh solvents or abrasive materials. Use soapy water and clear water rinse to remove any markings. When Graffiti is evident, remove markings with light mineral sprits solvent-DO NOT RUB THE SURFACE, wipe once to remove markings, wipe a second time to remove access.**

•Cyclical maintenance (less frequent and more extensive preventive measures, e.g., disassembly and inspection; reapplication of protective sealers; repainting; etc.): **Same as routine maintenance above.**

#### SPECIAL CONSIDERATION

•Provide detailed information about the artwork if it includes any electrical, mechanical, other unique or contemporary materials: Includes only electrical work— see electrical and structural engineer diagram — **TBD**

•Are there any electrical components (lights, motors, transformers, photovoltaic, etc), mechanical (bearings, springs, universal joints, etc), or unique materials (resins, plastics, expanded polystyrene, etc): **Yes, photocell and light fixtures — see cut sheets — TBD**

•Please provide detailed schematics of electrical components or mechanical drawings and names of manufacturers as well as detailed information of where the these components were purchased:  
**TBD**

•How often and in what ways should these components be maintained (tighten connections, replace bulbs, check timers, replace batteries, etc): **Replace bulbs when needed see lighting cut sheet—TBD.**

•Provide any other pertinent information for the care of the these components as well as location of electrical power disconnect, if applicable: **Power disconnect — see electrical diagram**

16. Gregory Beck Art Studio  
Fort Worth, TX 71633  
Total Budget: \$166,200



May 25, 2025

**Denton, TX**  
**Fire Station 5 Sculpture**  
**Public Art Project**



**GREGORY BECK**  
**Public Art | Design | Sculpture**  
[artbygregorybeck@gmail.com](mailto:artbygregorybeck@gmail.com)  
[ArtByGregoryBeck.com](http://ArtByGregoryBeck.com)

#### **ARTIST STATEMENT**

This is to express my strong interest in contributing a unique, large-scale 3D sculpture for Denton Fire Station #5.

As a native North Texan, I'm well acquainted with the region's extreme and unpredictable weather. This knowledge directly informs my approach to materials and construction. I prioritize durability, sustainability, and weather resistance—favoring UV-protected, low-maintenance materials designed to withstand indoor/outdoor elements while ensuring public safety. All of my designs meet or exceed ADA accessibility standards to ensure inclusivity and comfort for all visitors.

If selected for this project, I will develop and present a comprehensive 3D digital concept. This presentation will include high-resolution renderings, animated walk-throughs, and detailed documentation of the proposed design, fabrication methods, and an installation plan. Prior to final production, I will submit physical samples and mock-ups of all materials and finishes for review and approval. Throughout the project, I will document the process from conception to installation with updated videos and images.

Community engagement is a core part of my artistic process. In past projects, I have organized presentations for local schoolchildren, led Q&A sessions, and facilitated community meetings to gather feedback and encourage public involvement. I've also hosted portrait photo sessions with residents, including first responders, to create a sense of ownership, pride, and connection with the final artwork.

I believe my experience creating impactful public art, combined with my deep-rooted connection to North Texas culture and environment, make me a strong candidate for this opportunity. I am enthusiastic about the potential to contribute to the City of Denton's public art collection, and I look forward to the possibility of collaborating with your team on this exciting and meaningful project.

Thank you for your time and consideration.

Sincerely,



Gregory Beck

**GREGORY BECK**  
**Public Art | Design | Sculpture**  
[artbygregorybeck@gmail.com](mailto:artbygregorybeck@gmail.com)  
[ArtByGregoryBeck.com](http://ArtByGregoryBeck.com)

**CONCEPT IMAGES AND VIDEO LINK**











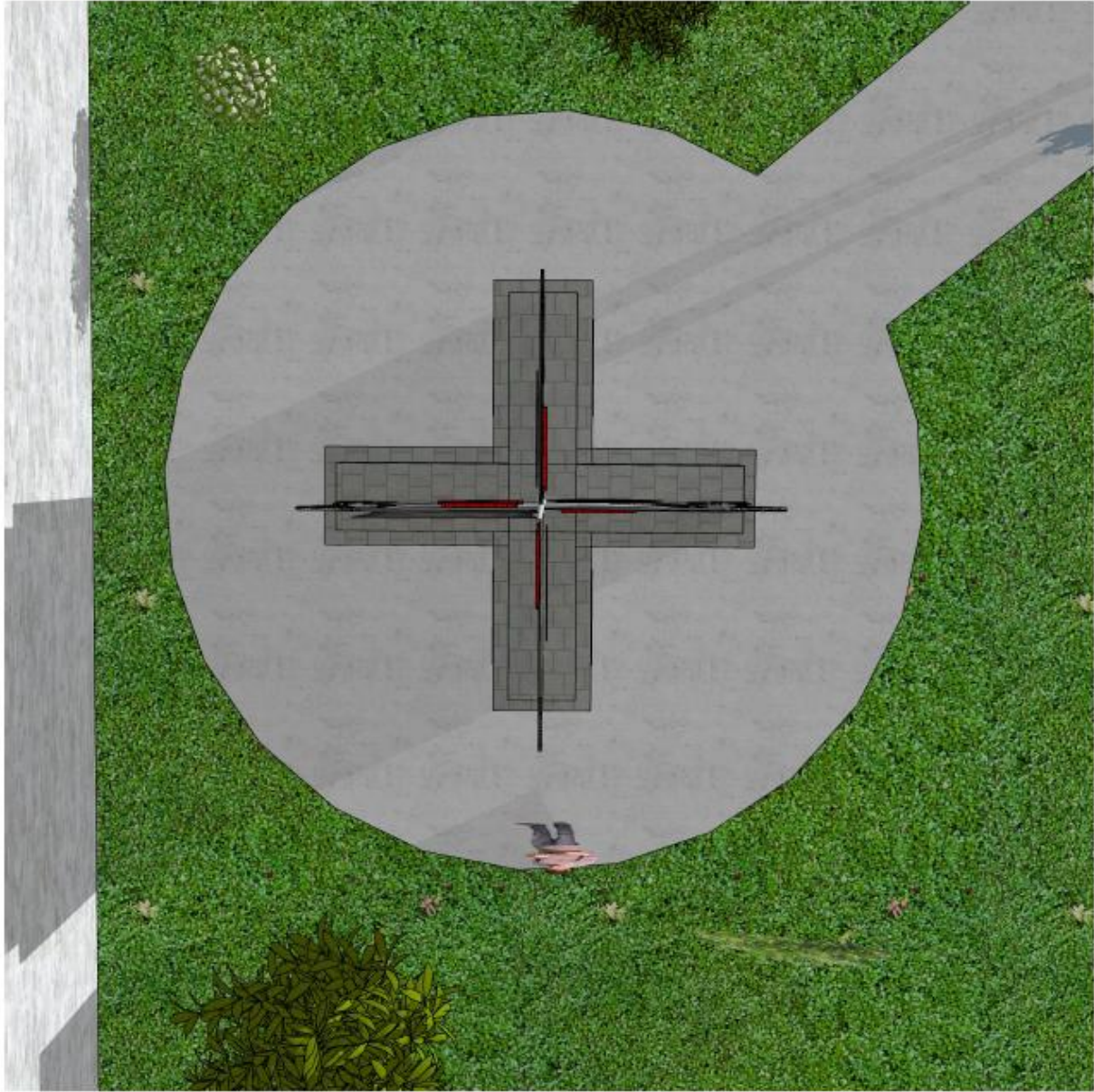

**YOUTUBE VIDEO LINK TO ANIMATED FLY-AROUND VIDEO:**

<https://youtu.be/qxVK59R96rs>

## **GREGORY BECK**

### **Public Art | Design | Sculpture**

[artbygregorybeck@gmail.com](mailto:artbygregorybeck@gmail.com)

[ArtByGregoryBeck.com](http://ArtByGregoryBeck.com)

#### **NARRATIVE – BUDGET – TIMELINE - MAINTENANCE**

##### **Concept Working Title: “We Have You Covered”**

My design envisions a sculpture comprising four water-jet-cut stainless steel panels, each measuring 4 feet high by 5 feet long, depicting silhouettes of firefighters in action. These panels will be oriented to face the four cardinal directions—North, South, East, and West. The concept symbolizes the readiness and commitment of Denton First Responders, prepared to respond wherever and whenever they are needed.

As viewers move around the sculpture, the transparent panels will create overlapping shapes and shifting shadows, offering a dynamic and engaging visual experience.

The sculpture will be mounted on a robust steel frame, which itself is encased in a brick-clad pedestal measuring 8 feet tall and 10 feet wide.

##### **Interpretive Plaques**

At least four stainless steel plaques, laser-etched with interpretive content, will be mounted on the brick pedestal's walls. The plaques will feature:

- A history of firefighting, with a focus on the Denton Fire Department and Station 5.
- An introduction to the station's mascot.
- A tribute to Fallen Firefighters, with smaller etched panels affixed to the main plaques in their honor.

##### **Additional Features**

- A centrally mounted flagpole displaying a custom flag featuring the department's mascot.
- An internally illuminated emblem of the Fire Department and the number “5,” lighted by a programmable LED lighting system. This system will flash to signal when the department is responding to an emergency call.

##### **Materials:**

Water-jet cut stainless steel panels with ½” tinted polycarbonate inserts to provide transparent areas. All panels to be supported by an engineered internal steel support structure. Mounted on a concrete base and brick clad pedestal.

**BASIC BUDGET ESTIMATE:**

Artist's Overhead & Studio Time for Research, Final Concept Design - \$ 20,500

Artist's Fee & Studio Time for Final CAD design - \$ 7,000

Engineering for support structure and foundation - \$ 9,500

Fabrication, Metal cutting, laser etching finishes - \$68,000

Foundation, Masonry, and Labor & Installation of Brick Clad Pedestal – \$ 42,700

Artist's Time quality control of fabrication and installation, Total Travel & Expenses - \$ 4,750

Ancillary items, flag pole & custom flag - \$2,250

Equipment Rental for Sculpture Delivery & Installation - \$ 6,200

Labor and expenses for Delivery & Installation of artwork - \$ 9,500

Programable, internal LED Lighting system, plus night testing- \$12,800

Contingency, Insurance & other Expenses - \$ 7,000

Basic Budget Estimate Total - \$ 166,200.00

17. Jen Garrett Art  
Newberry, FL  
Total Budget: \$100,000



## Artists Statement

As a public artist, I create sculptural installations that are rooted in place, shaped by community, and driven by narrative. My work engages themes of identity, resilience, and public service, often honoring the quiet heroism embedded in the everyday fabric of civic life. Through scale, material, and interaction, I aim to create artworks that resonate deeply—transforming public space into landmarks of meaning and memory.

Over the past 15 years, I have had the privilege of developing major public works across Florida and beyond, including pieces that celebrate first responders and the spaces they safeguard. My illuminated sculpture for Gainesville Fire Station 1, for example, honors the bravery and commitment of firefighters with a billboard-sized, light-responsive installation that has become a cherished part of the community. Its importance was affirmed when, during the construction of a new facility, the community insisted the artwork be relocated and preserved—an acknowledgment of the sculpture’s emotional and cultural impact. I have also created pieces like the Young Pine Park sculpture in Orange County, commemorating the opening of the county’s first inclusive playground, and reinforcing themes of access, empathy, and unity.

In developing works for fire stations and civic sites, I am particularly drawn to themes of heroism, selflessness, and the rich, often underrecognized histories of firefighting in Texas and across the United States. I see these projects as opportunities to both honor service and spark curiosity—to create spaces where the public can reflect on the human stories behind the sirens. My proposed work for Denton may include a responsive lighting component that is activated during emergency calls at the fire station, creating a visible, poetic gesture that links the physical sculpture with the living actions of those it honors. This approach—merging symbolism with interactivity—underscores my larger philosophy as a public artist: that art should not be passive. It should respond, engage, and bear witness. There is even opportunity to model the figure shown after a person of your choosing. For a city like Denton, with its forward-thinking approach to public art and its commitment to civic storytelling, I envision a permanent, iconic installation that is both visually powerful and emotionally resonant. A piece that honors the past, reflects the present, and stands as a beacon of shared values—community, courage, and care. Public art is most powerful when it becomes part of a city’s rhythm, identity, and story. With this work, I aim to create a sculpture that is not just seen—but felt—by generations to come.

A handwritten signature in black ink, appearing to read 'Jenn Garrett'.

Jenn Garrett



sketches/renderings

jgarrett



sketches/renderings





## BUDGET

Artist Fee (including concept and design development, site visits, meetings, insurance)	\$20,000
Design Documents	\$2,500
Engineering	\$3,500
Materials and hardware	\$20,250
Fabrication (appx 6 weeks)	\$36,000
Finishes	\$9,250
Transportation	\$4,500
Installation	\$3,500
Signage/Plaque	\$250

**Total: \$100,000**

"Jenn Garrett approached our call with great enthusiasm and passion to understand the environment and issues so that she could make a proposal that was just what we needed. And then she executed the work on time and on budget even in the midst of other projects."

*-Terry Olson  
Director  
Orange County Arts &  
Cultural Affairs*

18. Jennifer Troice / Hope Foundry  
 Dallas, TX  
 Total Budget: \$177,000



JENNIFER  
 TROICE

**ABOUT**

Jennifer Troice is a Mexican-American sculptor who began her artistic career playing the piano & harp. Troice uses smooth curves for human figures & a style she coined "geometric minimalism" for animals. Jennifer's work is exhibited publicly & privately, around the world, in small & monumental-scale formats.

**PASSION PROJECT**

Jennifer launched **Hope Foundry** in 2024 to spread hope & healing to those who have suffered due to trauma or a difficult diagnosis. With her charitable partners, we provide human connection & funding for mental health wellness.

**LANGUAGES** English  
 Spanish

**CONTACT**

jennifer@hope-foundry.com  
 972-977-8386  
 hope-foundry.com  
 @hope\_foundry  
 @jennifertroice

**EDUCATION**

<b>American School Foundation</b> 1996-2005	9-12th grade, Visual Art Studies, ASF
<b>Massachusetts College of Art</b> 2005	print-making drawing the human body welding foundry process
<b>Universidad Iberoamericana</b> 2005-2009	<b>Major:</b> Psychology

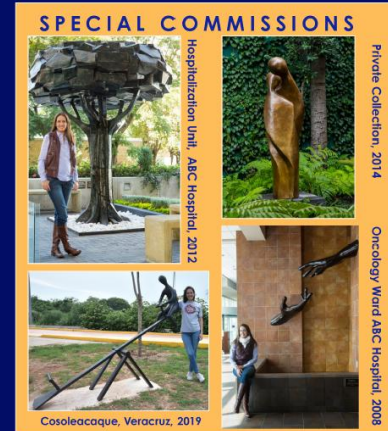

LETTER OF INTEREST

Dear Selection Committee Members,

I'm excited about the chance to design a monument honoring our brave firefighters and their selfless sacrifice for the Denton Community. This opportunity feels perfectly aligned with my artistic language, creative energy, and passion for sculpting meaningful, community-centered public art.

**WHY ME?**

I'm Jennifer Troice, a bronze sculptor with a gift for creating emotional connections through clean, modern forms. My substantial body of work includes multiple monumental sculptures.

My outdoor monumental sculptures, dating back to 2014, remain beautiful and timeless. Bronze is weather-resistant, requiring minimal maintenance. Safety is implicit in this format - size, weight, and strength. Installations are anchored with underground structures and cement, guaranteeing they won't fall over even if climbed on.

Working with board representatives, community, and business leaders is not new to me. I thoroughly enjoy the collaboration, from project launch to final installation. My life experience makes me particularly adept at listening, understanding, and incorporating input.

**RELEVANT EXPERIENCE**

To date, I have completed 14 public and private life-size bronze sculptures, including custom, site-specific, and community-responsive works.

I was commissioned to create THE VERACRUZ COLLECTION, an eight-sculpture series for a public park. The theme was celebrating human connection. The idea is that spending time on devices pulls us apart, while being outdoors playing brings us closer. One monument shows two figures playing jacks, together and fully present (JACKS). Another depicts a seesaw with an empty seat. Visitors frequently interact and play with the bronze child, and lots of photos are taken (SEESAW).

Each sculpture explores human relationships—friends, family, neighbors—all interacting outdoors, face-to-face. It's a reminder of the beauty in real connection, without screens in between. It was important to me that the sculptures be visibly and physically enjoyed.

Likewise, I've also designed, sculpted and installed a 10 ft. tall sculpture of a tree (TREE OF LIFE) weighing over 1 ton giving me the experience of installing large sculptures using a crane.

**DESIGN & IMPLEMENTATION OF THE WORK**

At project launch, I gather insight to ensure a full understanding of the vision.

Second, I create a small 3-D format model of the proposed sculpture to enable suggestions or changes before crafting the full-scale sculpture.

Once the design is finalized, I begin site construction planning with my team.

I can't wait to learn more about your dream sculpture and am excited to bring it to life! I am available for meetings and to work within the budgetary and time constraints proposed. I hope my extensive experience, creativity, and ability to respond to unforeseen bumps give you the peace of mind that the outcome we create will be exceptional.

JENNIFER TROICE

Warm regards,

*Jennifer Troice*  
 Jennifer



# DESIGN PROPOSAL

I envision a bronze sculpture of 2 firefighters responding to a call. The water coming out of the hose is composed of a glass piece created by Carlyn Ray (Dallas glass artist) and will light up whenever the fire alarm goes off. The base is a representation of the cement foundation and can be adjusted in shape, size and/or material.



I'm submitting the same design for both fire stations, as its aesthetic complements each site. I genuinely believe it aligns with and supports the goals of this meaningful project.

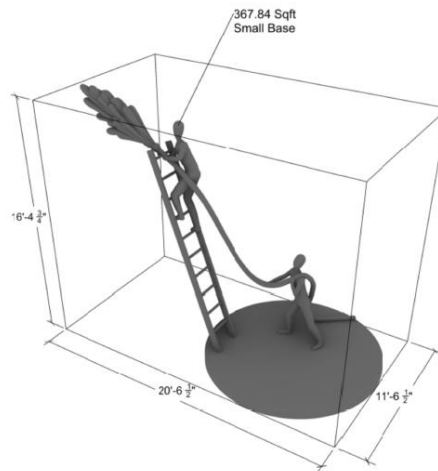
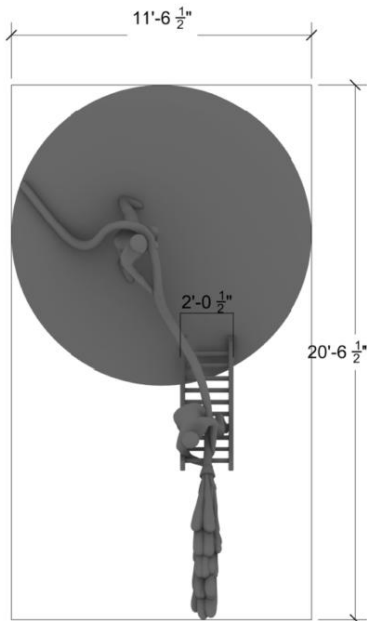

19. KTCreature, LLC.  
New York, NY  
Total Budget: \$150,000

## City of Denton Fire Station #5 Sculpture Proposal

Katherine 'KT' Taylor



KT '25

[www.katherinekttaylor.com](http://www.katherinekttaylor.com)

Dear Members of the Selection Committee,

I am thrilled to submit my letter of interest for the City of Denton's Fire Station #5 Public Art opportunity. As a metal sculptor with over 20 years of experience creating large-scale, permanent outdoor artworks, I am eager to propose a vibrant, iconic sculpture that honors the courage and dedication of Denton's firefighters and their enduring legacy of service to the community.

For this project, I envision a dynamic, larger-than-life sculpture featuring a horse and a Dalmatian, crafted in durable, weather-resistant metal. This concept pays homage to the historical role of horses in pulling fire carriages and Dalmatians in alerting communities and calming horses during emergencies. The horse would be depicted standing calmly, its head lowered to nearly touch noses with the Dalmatian, which gazes up with alertness and loyalty, capturing the deep bond of true friendship between them. To enhance visual impact, I would employ my signature "texture swapping" technique, integrating tactile surfaces inspired by firefighting gear—such as the weave of hoses or the grain of leather—alongside natural textures found in the Denton area.

Designed for durability in Denton's climate, the sculpture would use low-maintenance materials like stainless steel or bronze, ensuring longevity and safety. The piece would serve as a landmark that delights residents and visitors, embodying the spirit of community resilience and the vital role of the fire station. The proposed budget cover all

costs, including design, engineering, materials, fabrication, site modifications, and installation.

My recent projects demonstrate my ability to deliver impactful public art within budget and timeline constraints. I completed The Lion Family, a bronze sculpture for Easton Park in Austin, TX, and am currently fabricating a 13-foot stainless steel falcon for the University of Texas Permian Basin. These works reflect my expertise in creating enduring, site-specific art that resonates with communities. I am prepared to work closely with Denton's team, local engineers, and fabricators to ensure seamless integration and compliance with all project requirements.

you for considering my proposal. I am excited about the opportunity to contribute to Denton's artistic legacy and look forward to the possibility of further developing this concept.

Sincerely,



**Katherine 'KT' Taylor**

1707 1/2 Post Oak Boulevard #137, Houston, TX 77056

Tel: +1 979 571 5045 • Email: ktcreature@gmail.com • www.katherinekttaylor.com

## FIRE HORSE AND DALMATIAN

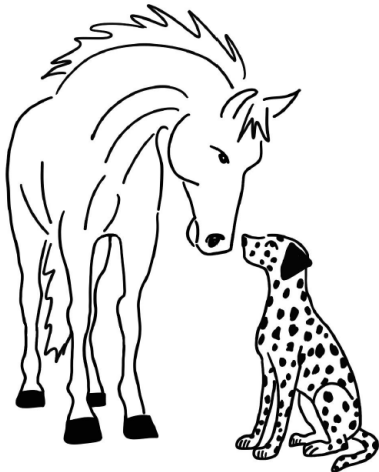

**Materials:** Bronze or Stainless Steel

**Size:** 10'(H)x12'(L)x3'(W) , Fire Horse

4'(H)x3'(L)x2'(W) , Dalmatian

**Budget:** \$150,000 approx.

KT '25

past work images





20. Maxwell Emcays  
Chicago, IL  
Total Budget: \$200,000

## PROPOSAL

1. Resumé of the principal artist submitting the proposal that demonstrates completion of previous projects of similar scale.

### MAXWELL EMCAYS

Public Artist | Philanthropist | Author

 312.888.0640 |  hi@emcays.com

 [www.Maxwell.Emcays.com](http://www.Maxwell.Emcays.com)

 55 E Monroe Suite 3800, Chicago, IL 60616

---

### EDUCATION

BFA, University of Illinois, 2011

---

### SUMMARY

Multidisciplinary public artist with over 15 years of experience completing large-scale public art installations across the U.S. Known for community engagement, innovative design, and ability to collaborate with municipalities, architects, and engineers. Proven track record delivering impactful artworks that reflect cultural identity and civic pride—on time and within budget.

### ARTIST SUMMARY

As a multidisciplinary artist dedicated to public engagement and narrative-driven design, an iconic, permanent work that not only enhances the architectural presence of the site, but also celebrates the spirit of protection, service, and unity embodied by first responders.

My creative process begins with deep community engagement and historical research, allowing me to reflect the identity and values of the people the station serves. The sculpture I envision for this site will act as a beacon—symbolic of vigilance, resilience, and the bond between the fire department and the community. Drawing from my previous work on large-scale installations across the country, including both freestanding and integrated public pieces, I understand the engineering, logistical, and collaborative rigor that such a project demands.

I employ CAD design throughout the creation process to ensure seamless communication with engineers, fabricators, and city project managers, allowing the artwork to meet structural, environmental, and maintenance standards from concept through installation. From a design perspective, I am interested in merging durable materials like plasma-cut aluminum and integrated lighting (LEDs) to craft an installation that is both enduring and dynamic—changing with the day's light and inviting interaction and reflection.

This project is an opportunity to honor the bravery and humanity of Denton's firefighters through the universal language of public art. I am enthusiastic about contributing to this historic moment in Denton's public art evolution with a work that is as bold and enduring as the commitment it commemorates.

Total Project Budget: \$200,000

Category	Details	Amount (USD)	% of Total
1. Administrative Costs	Insurance, project management, travel	\$10,000	5%
2. Artist Fees	Creative concept development, design work	\$30,000	15%
3. Pre-Fabrication	Engineering, modeling, shop drawings	\$24,000	12%
4. Fabrication	Materials & parts, shipping, fabricators, studio rental	\$76,000	38%
5. Installation	Site prep (concrete, trades), install labor & equipment	\$30,000	15%
6. Concrete Fabrication & Install	Specialized base and structural foundation	\$25,000	12.5%
7. Contingency	Design modifications, material increases, inflation buffer	\$15,000	7.5%
<b>TOTAL</b>		<b>\$200,000</b>	<b>100%</b>

---

Design Sketch

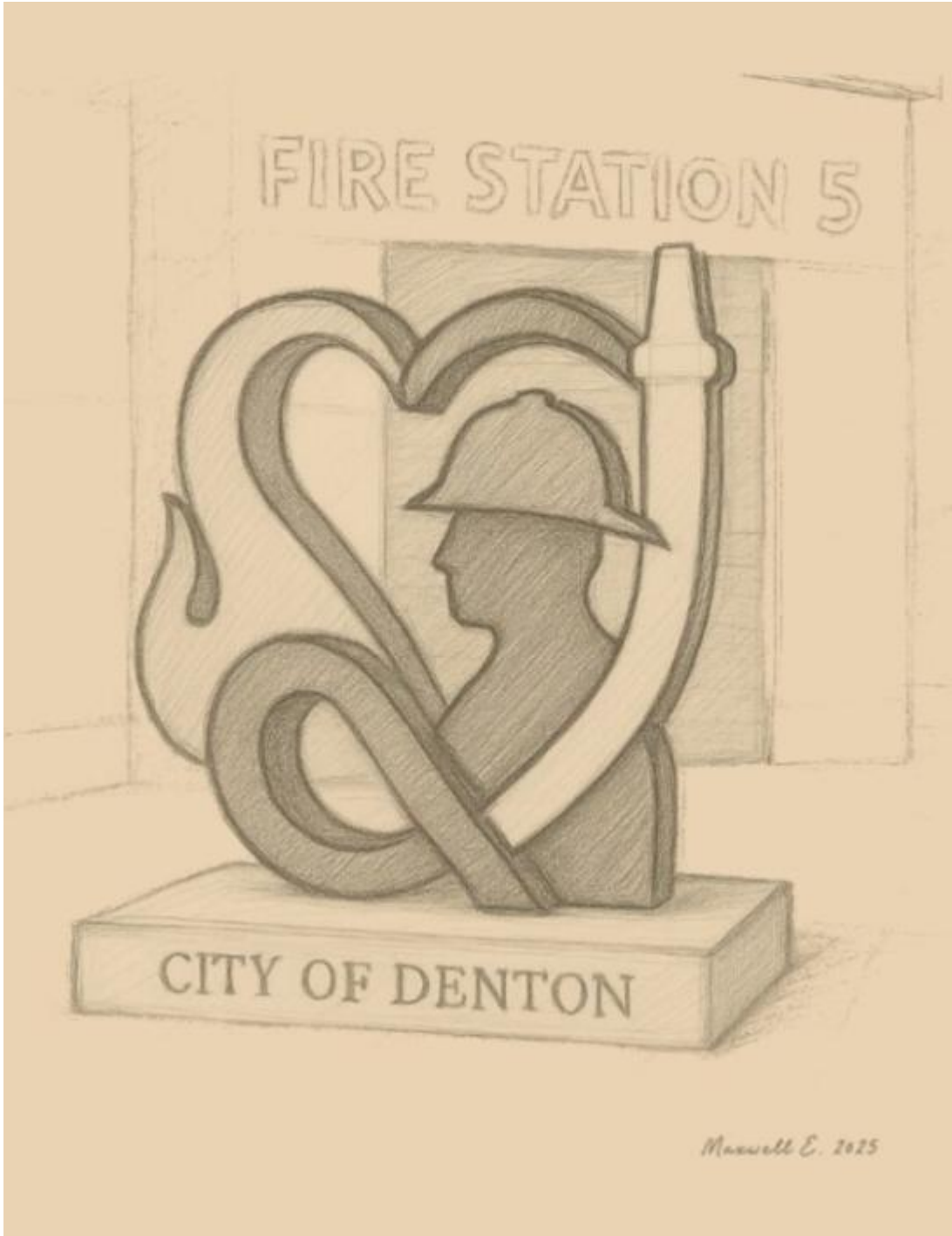



21. McCall Studios  
Boise, ID  
Total Budget: \$200,000

### Letter of Interest

Each public art project has its own potential, and my approach is to create a new design for each opportunity. I am a sculptor based in Boise who specializes in creating enduring works from metal. For over 25 years I have been sculpting contemporary works that combine clean, flowing lines with unexpected details. My fabrication skill set serves not only my own art but allows me the opportunity to collaborate with artists of other disciplines to design and create unique works. Regionally I have collaborated with many Boise artists on several recent projects and have worked with the nationally renowned sculptor Arthur Higgins. Some of my recent notable works are *Circuitree* for Greeley, CO; *Transference* for Boise State University; a multiple sculpture design and installation for The City of Bend, OR; an entryway sculpture for the Inn at 500 in Boise, ID; *24/7* and *Call and Respond* for Fire Stations #4 and #8 in Boise, ID; a kinetic sculpture powered by the wind for Heroes Park in Meridian, ID; an iconic free-standing sculpture *Spiral of Injustice* at the Idaho Anne Frank Human Rights Memorial in Boise, ID; a kinetic sculpture representing a historic park and its relationship with the surrounding community throughout time for Munson Park in Norfolk, VA; *A New Leaf* for Bates Technical College in Tacoma, WA; a placemaking sculpture, *Pillars of the Community*, at Fire Station No. 36 in El Paso, TX; *Ambassador's Portal* at Don and Anne Davis Park in Newport, OR; a multi sculptural bench installation for a senior living center in Broomfield, CO; a roundabout sculpture of a mare and her foal celebrating the spirit of rodeo in Nampa, ID; a didactic piece commemorating the City of Nampa in the heart of downtown in Lloyd Square; an entry way sculpture celebrating community upstanders at the Wassmuth Center for Human Rights in Boise, ID; *Vita Nova* celebrating new life for Rogers Farm neighborhood in Superior, CO; and an entry way metal relief sculpture signifying how individuals in the community make up the local landscape for Monroe Detention Center in Woodland, CA.

Working in primarily metal allows the flexibility to produce both delicate and monumental objects of art that can live in almost any space. The materials I work in most often are aluminum and stainless steel which are extremely versatile for lasting outdoor installations. The meticulous construction methods that my studio employs often give a seamless quality to the art to emphasize the elegant lines of the design. Color is used carefully to enliven the space and I often incorporate other materials in the work as important details. Recent pieces have utilized gilding, mosaic, acrylic and specialized finishes to enhance the design.

Because I work from the template of an original artisan, commissioning agencies get the advantage of outstanding service that often gets lost in the vastness of many art corporations; I personally answer all of my own phone calls and emails, design all of my own artworks, fabricate all of my own designs, and work directly with the architects, contractors, engineers, neighborhood associations and city planners in a team effort. In addition, fabricating my own designs gives me the experience needed to propose designs that are feasible for the determined budget, as well as the advantage of being in better control of meeting timelines and staying within that budget as I don't have the cost of hiring someone else to build my artworks. The resulting art is a combination of artistic vision, solid craftsmanship, and careful integration of the piece in the natural setting.

I am confident in my abilities to design, fabricate and install unique artwork for The City of Denton's Fire Station 5. The skills needed to do so; meticulous craftsmanship, solid fabrication, and practical experience with permanent materials; are skills that I have been employing on many individual installations internationally. This is an exciting opportunity to create artwork that captures the essence of the community to engage, uplift and provoke thought in those who interact with it. I believe that my own artistic vision united with years of professional design, fabrication, and collaborative working experience contribute to give me extensive knowledge of working on artwork as well as combine to make me a unique candidate.

Thank you for your consideration,  
Ken McCall

## Proposal



Paying tribute to firefighters' courage, *Heroes Gateway* represents the idea of Fire Station 5 being a space that assists the men and women it houses to prepare for their valorous community service; a space that helps transform heroes.





Maps of the area the fire station serves are engraved into the pillars while the station's emblem is displayed on the top, representing the relationship between the two.







Waves are used to represent the beach location of Fire Station 5 as well as signify the importance of water; the universal symbol of life and the vital resource used by the firefighters to protect it.







Blue lights will light up *Heroes Gateway*, which will turn to red to signal the station's calls.





*Heroes Gateway* will stand approximately 17.5 feet high, measure about 4 feet by 4 feet at the base and 7 feet by 5 feet at the top.



### Budget

Engineering	\$2,000
Insurance	\$500
Permits/Fees	\$1,500
Materials	\$40,000
Fabrication	\$80,000
Transportation/Travel	\$10,000
Installation	\$10,000
Research/Site Installation Modification	\$26,000
Contingency	\$20,000
Artist/Design Fee	\$10,000
<b>Total</b>	<b>\$200,000</b>

22. Jeffie Brewer / Orange Cat  
Nacogdoches, TX  
Total Budget: \$175,000

HI MY  
NAME  
IS:  
**JEFFIE.**



**Jeffie Brewer**  
jeffie@jeffiebrewer.com

936.552.6078  
305 CR 813  
Nacogdoches, TX 75964

**JeffieBrewer.com**

**GREETINGS!**

1

To the City of Denton Public Art Committee:

Please accept this letter as my formal expression of interest in creating a public sculpture for the Denton Fire Station. I'm honored by the opportunity to contribute a work that speaks to the deep tradition of heroism, selflessness, and service embodied by firefighters in Texas and across the country. This is more than a public art opportunity—it's a chance to honor those who run toward danger, and to create a visible tribute to their strength, sacrifice, and humanity.

As a sculptor specializing in large-scale steel work, I'm drawn to this project's potential to combine strong visual presence with symbolic depth. My goal would be to create a piece that resonates with the legacy of firefighting—one that invites the public to reflect on the courage and history of those who serve, while also providing a bold and lasting landmark for the community.

Over the past 15 years, I've developed a practice focused on public art—crafting vibrant, durable sculptures that encourage interaction and emotional connection. My work has been found in parks, city centers, trails, and museums across the country, including Crystal Bridges Museum of American Art. Each piece is designed to be approachable, meaningful, and built to withstand time and weather.

For Denton's Fire Station, I envision a sculpture that blends historic references with modern form—possibly incorporating a lighting component that activates in response to emergency calls, making the piece a living part of the station's operations. This interactive element could symbolize the constant readiness and heartbeat of the station, quietly acknowledging each call to action in real time.

Fabricated from powder-coated stainless steel or aluminum, the sculpture would be designed for durability, low maintenance, and high visibility—potentially incorporating bold color and strong silhouette to ensure it remains a striking presence both day and night. I have extensive experience working with municipalities, engineers, and site contractors to ensure my sculptures are structurally sound and seamlessly integrated into their environments.

I would welcome the opportunity to collaborate with the City of Denton and local stakeholders to shape a concept that reflects both the historical and present-day identity of the Denton Fire Department. My process includes site visits, material selection, and close coordination to ensure the final piece is not only impactful but genuinely rooted in its place. While I have separate proposals I am happy to combine or mix and match ideas.

Thank you for considering my work for this meaningful project. I look forward to the opportunity to contribute to Denton's public art landscape and to celebrate the vital work of its firefighters through sculpture.

Respectfully,



Jeffie Brewer



HI MY  
NAME  
IS:  
**JEFFIE.**



**Jeffie Brewer**  
jeffie@jeffiebrewer.com

936.552.6078  
305 CR 813  
Nacogdoches, TX 75964

**JeffieBrewer.com**

## Artist Statement Short

I make things. My work balances play and precision, drawing from a childhood spent in a junkyard and years teaching art. Using simple forms, bold color, and playful design, I create sculptures that invite curiosity, joy, and connection. I believe art is a way for people to see the world—and each other—differently. Through public art, I aim to spark delight in everyday spaces and offer moments of shared recognition, humor, and wonder.

## Artist Statement Longer

I make things. I have an insatiable desire to create, explore, and understand—to transform ideas into tangible, lasting forms. My work is an extension of both my hands and my head, a balance of craftsmanship and curiosity, structure and spontaneity.

I strive to provide just enough information and form to spark recognition while leaving room for interpretation and mystery. I want my sculptures to engage, invite, and surprise, offering a shared moment of discovery between the viewer and the work. Playfulness and simplicity are tools I use to communicate ideas that are often deeply personal yet universally accessible. My background in graphic design, fascination with pop culture, and love of storytelling all filter into the work, shaping its rhythm, color, and presence.

Art, to me, is about connection. We are given only a brief amount of time together, and in that time, art allows us to laugh, think, remember, and feel—to acknowledge the full spectrum of experience, from the profound to the absurd. Sometimes my work is serious or contemplative, but most often, it embraces the joy and absurdity of being alive.

I have been incredibly lucky to learn from great mentors, teachers, and friends, and I consider it an honor to pass that forward. Through public art, I have found my most meaningful creative fulfillment—the ability to directly connect with people in unexpected places and everyday moments. Seeing my work become part of a landscape, part of someone's daily routine, part of a child's imagination or a stranger's delight, is the greatest reward.

At its core, my work is an invitation—to see, to engage, to wonder, to smile. If I can add even a moment of joy, curiosity, or recognition to someone's day, then I consider that a success.

# BUDGET YOU SAY: JEFFIE.



**Jeffie Brewer**  
jeffie@jeffiebrewer.com

936.552.6078  
305 CR 813  
Nacogdoches, TX 75964

**JeffieBrewer.com**

<b>I. Sculptures</b>	
A. Powder Coated Sculpture 12-15'	\$50,000
B. Medium Stainless Powder Coated Sculptures 6-8'	\$32,000
<b>II. Artist Fees</b>	
A. Design and Conceptualization	\$4,000
B. Fabrication and Installation	\$25,000
C. Project Management	\$7,000
<b>III. Site Preparation</b>	
A. Excavation Site Clearing and Grading	\$4,000
B. Concrete Pads and Foundations	\$20,000
<b>IV. Equipment and Tools</b>	
A. Crane Rental for Installations	\$5,000
<b>V. Permits and Approvals</b>	
A. Engineer	\$5,500
B. Environmental Compliance, Permits	?
C. Safety Inspections	?
<b>VI. Contingency</b>	
A. Unforeseen Contingency	\$8,000
<b>VII. Documentation and Publicity</b>	
A. Photography and Press Availability	\$500
<b>VIII. Miscellaneous</b>	
A. Insurance	\$2,000
B. Travel Expenses	\$6,500
C. Miscellaneous Supplies	\$2,000
D. Electrician	\$3,500
	<b>\$175,000</b>

## Timeline

Design notes and ideas to me Month 1, video conference to discuss.  
Finished designs by Month 1-2. Second meeting to approve soon after.  
Concrete work 80-100 days out from agreement to proceed.  
Electric work before and after concrete work.  
Sculptures installed 200-230 days from agreement to proceed.  
These can be moved around if something takes priority.



### Design 1 *FIREMAN*

This sculpture honors the enduring legacy of heroism, selflessness, and service embodied by firefighters in Denton and across the country. Bold and unmistakable in form, the figure represents generations of individuals who have answered the call—not for recognition, but out of a deep sense of duty to protect others. With one hand raised to hold a hose and the other steadying a ladder, the silhouette pays tribute to both the visible and unseen labor of firefighting: the courage to step forward, the strength to carry weight, and the quiet resolve to serve without hesitation.

The sculpture's form is rooted in history, yet its presence is forward-looking—meant to stand not only as a symbol of past sacrifice, but as a beacon for future generations. A proposed lighting feature at the end of the hose would subtly activate during emergency calls, creating a gentle glow that signals action without spectacle—a respectful nod to the ever-ready spirit within the station.

Alongside this piece, I would welcome the opportunity to collaborate on a second, yet-to-be-designed sculpture. This companion work could explore additional layers of community identity and would benefit from thoughtful dialogue with station staff and city stakeholders to ensure it feels personal and true to place.





## Design 2 Action

These two sculptures celebrate the spirit of teamwork and selflessness at the heart of firefighting. In both, a group of stylized firefighter figures work together to support the bold red letters of "DENTON 5," representing not just a station number, but a unified community of service. Each figure holds their part without individual attention—just strength, purpose, and trust in one another. A lone firefighter stands atop the "5," raising an axe in recognition of those who serve quietly, dependably, and with courage.

The sculptures are designed to be interchangeable in placement—either piece could be the primary or secondary installation. One is scaled as a larger focal point, while the other works beautifully as a complementary or freestanding smaller work. Whether installed together or independently, they serve as powerful symbols of collective effort, shared responsibility, and the deep honor of showing up for others without needing to be asked.





### **Design 1 *Play***

This installation turns the Denton Fire Station into a joyful, storybook setting—anchored by a larger-than-life Dalmatian sculpture wearing a bright red firefighter's hat. It's cheerful, charming, and impossible not to smile at. Perched just outside the station, the dog stands proudly with its nose pointed forward—doubling as a soft spotlight that beams across the building at night, as if keeping watch.

But the fun doesn't stop there. Scattered throughout the grounds are playful little surprises—colorful Easter eggs in the form of smaller sculptures: a curious squirrel peeking from a wall, a bunny near a bench, a sleepy yellow pup resting near the ladder, and a bright red bird perched somewhere unexpected. These little characters reward exploration and give returning visitors something new to spot every time.

Together, the elements create a warm, welcoming space that celebrates firehouse culture without ever getting heavy. It's about friendliness, imagination, and the joy of community. This is public art that makes kids laugh, grown-ups grin, and neighbors linger just a little longer. Whether you're visiting for a tour or just walking by, it's the kind of place that makes you feel like you've stumbled into something special—and maybe just a little magical.

23. Ray King Studios  
Stockton, NJ  
Total Budget: \$175,000

**R A Y K I N G**

945 Sergeantsville Rd, Stockton, NJ 08559

Te l: (215) 266-4222

[raykingstudio@gmail.com](mailto:raykingstudio@gmail.com) – [www.raykingstudio.com](http://www.raykingstudio.com)

**S T A T E M E N T**

I strive to create wondrous, welcoming works of art to enhance public spaces and appeal to all ages. I use the phenomena of light as an art medium, creating dynamic interactions that refract light into color. My art reflects my interest in geometry, science, technology, light and color to create luminous, interactive sculptures that welcome the public and uplift the spirits of viewers -- to make the mundane magical.

I've been a working artist for nearly 50 years with more than four decades experience in public art. My designs are site-specific, inspired by the surroundings to create a unique sense of place. I work with durable materials – laminated safety glass, stainless steel and concrete – to create long-lasting monumental artworks. Two common design concepts in my work are “beacons” or “lens” structures that act as optical instruments to capture and re-direct light and color projections into the surrounding space to animate the environment.

Working with glass, metals and laminating films, my sculptures are designed to interact with the sun and/or artificial light, projecting and reflecting light and color into the surrounding space, shifting color and transparency and changing appearance with the times of day and degrees of sunlight. I use the phenomena of light as it interacts with the optics of glass as an art medium, creating dynamic interactions with light, refracting it into colors -- rainbow emanations that change as the viewer moves.

I'm an extremely organized, seasoned professional, with a keen sense of organization and project management. I have experience working with teams, enjoy the R & D process and excel at structural details. Most of my projects are done in collaboration with government agencies, community groups, real estate developers, cultural commissions and construction crews. Many of my projects have involved substantial community consultation and public participation plans that range from design charrettes, school presentations for students, lectures, video productions, book publishing and tours. Public art can be a source of pride for a community as it adds beauty to the landscape. I welcome feedback to my designs – the process generally improves the final product and generates enthusiasm from the community. I consider this intrinsic to the public art process.

Finally, my art is designed with the highest concern for safety, made from durable materials and are generally maintenance-free and vandalism-proof.

**RAY KING STUDIO PRESENTS**

[www.RayKingStudio.com](http://www.RayKingStudio.com)

**DENTON BEACONS**



**D-STAR**



**D-SPHERE**

Two Proposals of Possibilities for Luminous Free-Standing Sculptures  
To Enhance and Animate the Denton Fire Stations #5 and/or #6



## **INTRODUCTION & INSPIRATION**

I strive to create wondrous, welcoming works of art to enhance public spaces. I use the phenomena of light as an art medium, creating dynamic interactions that refract light into color. My art reflects my interest in geometry, science, technology, light and color to create luminous, interactive sculptures that welcome the public, animate the environment, and uplift the spirits of viewers -- to make the mundane magical.

Over the past five years, I've created a series of what I call Celestial Objects. There are two main categories within these creations: dichroic glass-clad dodecahedrons and spherical structures enmeshed with laminated dichroic glass discs and a smaller stainless dodecahedron star within them. Inspired by Buckminster Fuller's 'Bucky Balls', these geodesic structures not only reflect a purity of geometry inherent to the natural world but are also considered by engineers to be the most durable structural building block available to us.

For the Denton Fire Stations' RFPs, I am proposing two luminous, cosmic sculptures:

### **G - STAR and G - SPHERE**

Both are inspired by the concept of a "Beacon," from the old English verb "to beckon to come" and a "Lighthouse" that guides and helps navigate waterways through the darkness. They are distinct, but aesthetically-related, sculptures, I am offering both versions to both Fire Station #5 and Station #6 to select one.

These free-standing geometric sculptures are fabricated and ready for installation. Made with laminated dichroic glass elements designed to interact with light to dynamically change colors depending on the angle of light and the movement of the viewer in space, the Denton Beacon(s) will be a strong and glowing visual landmark, as well as an iconographic symbol for the community. The Beacons will be visible to passers-by and from a distance to fully experience the changing colors, light projections/reflections and shadows.

The Beacons will be illuminated at night by a solar powered LED light fixture hidden within the sculpture's base. I could install programable lighting that could b





## BUDGET \*

Artist's Fee	\$28,000
research	
design development	
drawings / model / construction documents	
construction/installation supervision	
Artwork Cost	
materials	33,000
fabrication	28,000
shipment	4,000
Consultants	
assistants	12,000
engineering	4,000
Miscellaneous Costs	
studio expenses	8,000
insurance	4,000
travel	6,000
documentation	3,000
contingency	10,000
Installation	35,000

**TOTAL PROJECT BUDGET:**

-----  
**\$175,000**

- Programmable lighting not included

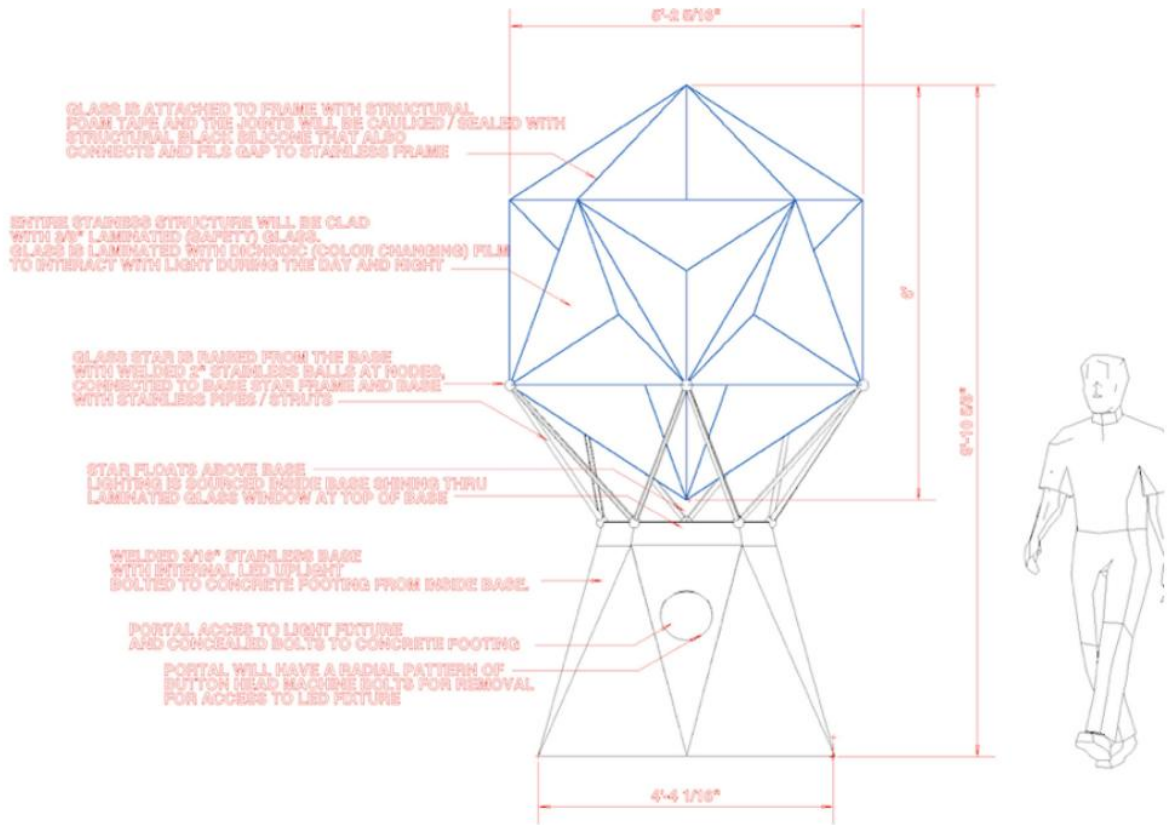

24. Scott Shubin  
Dallas, TX  
Total Budget: \$175,000 or \$200,000 (solar power)

#### **SCOTT SHUBIN SCULPTURE**

**Proposal Title:** *"Flame" – A Tribute in Light and Form*

**Artist Statement:**

I propose a large-scale contemporary sculpture titled *"Flame"* for installation at the newly constructed Fire Station #5 in Denton, Texas. This bold and symbolic sculpture is designed to reflect the courage, energy, and spirit of the fire service while complementing the station's modern architectural aesthetic.

*Flame* will feature three stylized flame elements—tall and dynamic—intertwining near the top to evoke movement and unity. These forms will be fabricated from high-grade stainless steel and inlaid with translucent acrylic panels in vibrant hues of red, orange, and yellow. The result will be a powerful, eye-catching piece that commands attention both day and night.

To enhance the sculpture's visibility after dark, I propose integrating lighting—either through a direct connection to the fire station's electrical system or through a commercial-grade solar power setup. I have previous experience successfully implementing solar-powered lighting in large-scale sculptures. This dual approach ensures flexibility in installation and environmental sustainability.

The sculpture will serve as a beacon of dedication, resilience, and public service—values that are synonymous with Denton's firefighters. Positioned prominently, *Flame* will be an inspiring and welcoming symbol for the community.

**Key Features:**

- **Materials:** Stainless steel structure with vibrant, weather-resistant translucent acrylic inserts.
- **Scale:** Monumental size (exact dimensions to be determined in coordination with site specifications).
- **Design:** Three intertwining flame elements rising from a unified base.
- **Lighting:** Integrated lighting system, either hardwired or solar-powered.
- **Visibility:** Visually striking during the day and illuminated at night for round-the-clock presence.
- **Durability:** All-weather construction with vandal-resistant materials.

**Conclusion:**

*Flame* honors the bravery and commitment of Denton's fire personnel through dynamic form and light. Its modern design complements the new facility while engaging and inspiring the public. This sculpture will be a lasting tribute and a functional landmark that reinforces pride in the station and the city it serves.



25. Seth Emerson Palmiter  
Rockport, ME  
Total Budget: \$200,000

SCHEMATICS EXAMPLE #1, Approximate Dimensions

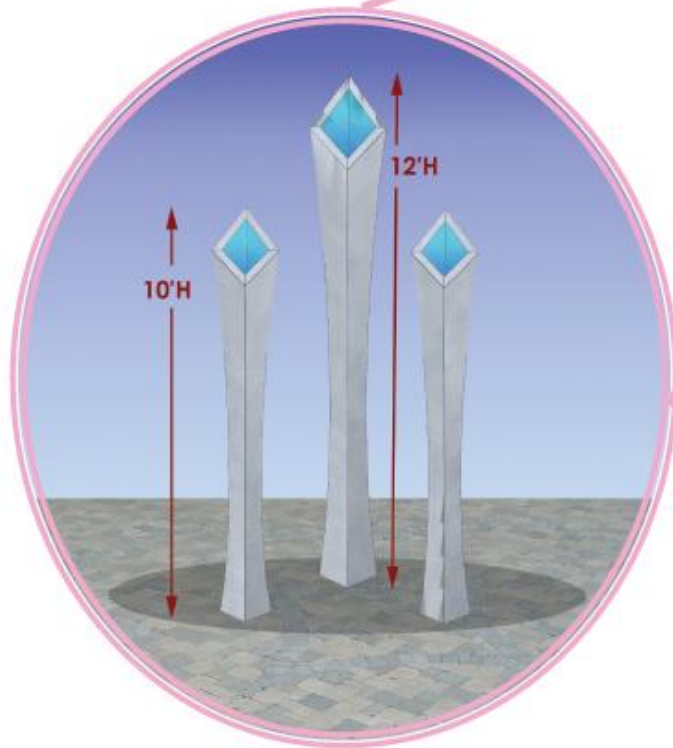
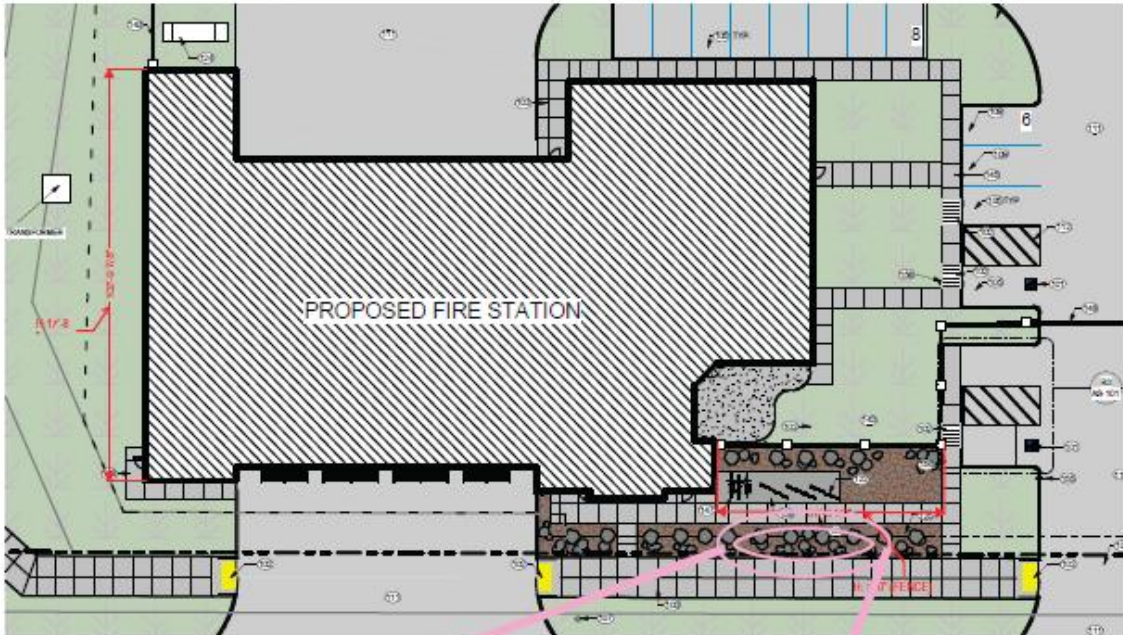

SCHEMATICS EXAMPLE #2, Approximate Location



SETH PALMITER 691 Rockland Street, Rockport, ME 04856 207-706-4140 Seth.Palmiter@gmail.com



## LETTER, Denton Fire Station #5 Public Art Opportunity

As a public artist for over twenty years, I have a wealth of capital project experience developing site-relevant public art for civic entities. I have a strong command of the skills, industry-relevant protocols, and criteria that result in beautiful, durable, dynamic public art. I am based in Mid-Coast Maine and my public art can be found in all corners of the country, California, and Alaska. I am adept at the design, fabrication, transport, and installation of significant public works. As both designer and fabricator, I am able to deliver art that is more than the sum of its part. My ability to innovate process and employ sophisticated construction techniques allows me to create monumental work within an economy of construction. I bring practical, industry-standard solutions within the envelope of lyrical, beautiful art.

My public art practice is a confluence of design, vision, materials, and mission that encourage discussion and elevate the public realm. I have experience incorporating representational theme, signage, wayfinding elements, seating, and lighting in my public art and will work with you to include any of these nuanced solutions to the Fire Station #5 Opportunity. My portfolio underscores the scope of my versatility. I am nimble mixing and matching process, material, and styles to achieve signature, targeted public art; every project is curated to suit its' site and regional cultural narrative. Though I have a wide array of compositions, the unifying attributes in my art are: Museum-caliber craftsmanship; innovative fabrication; durable, beautiful materials; and lyrical, dynamic, implied motion. My commissions nest harmoniously in their site, serve as visual stepping stones, and interact/respond to natural light; these interactive qualities endow the art to function as a living canvas, inspiring by day, night, and from season to season. The confluence of forms, ever-changing optics, and precise geometries imbue every Palmiter sculpture with universal appeal to a diverse audience. These attributes are a fit to achieve your art goals.

I design with an eye towards the "in between"; that is, not only the art, but the negative spaces created by the art, add nuance to my commissions. I seek to create sculpture that is beautiful from any angle, in harmony with the surrounding landscape, and regionally relevant to celebrate local community. Given your targeted criteria, I am interested to develop one signature sculpture that is uplifting and has an interactive light element when Firefighters are called upon; additionally, I can reserve budget to include a more representational wall art feature along the Station facade you identified for possible art. The Art Suite I develop will honor the dedication of Denton Firefighters and Safety Workers, provide an uplifting landmark for the City, and serve as a welcoming feature for residents and visitors. This signature Art Suite will provide critical way-finding, punctuate the processional experience, and serve as a memorable Station ambassador. I am qualified and interested to collaborate with Stakeholders to refine this concept; together we will set an uplifting tenor that celebrates public safety workers, your history, heritage, and the livability of Denton.

The materials I use are stainless steel, bronze, stone, glass, formed metals, acrylics, etched glass, and marine grade paint. These materials remain beautiful under the rigors of harsh UV exposure, wind, rain, freeze/thaw, and pollution; these are responsible material choices which resist vandalism. I have experience in the modalities of architecture, engineering, construction, rigging, and other technical systems which enable me to analyze and execute rigorous design solutions while transitioning between technical and artistic disciplines.

The public art I create is akin to a cultural bridge bringing people together through a shared aesthetic experience. Sculptors view their world as a canvas. We seek out ever larger expanses to enliven; humanity benefits from these art experiences. It is a privilege that my life's work allows me to enhance civic spaces for many; whether developing work for a university, a hospital, a transit facility, or a City, I am honored to participate in this endeavor. I appreciate your review and thank you for participating in the public art process.

**SETH PALMITER** 691 Rockland Street, Rockport, ME 04856 207-706-4140 Seth.Palmiter@gmail.com

## BUDGET, Denton Fire Station #5 Public Art Opportunity



Artist fee	\$ 10,000
Administration	\$ 3,500
Stainless Steel	\$ 32,500
Glass/Finishes	\$ 4,500
Fabrication	\$ 85,000
Wall Sculpture	\$ 30,000
Travel	\$ 3,500
Art transport	\$ 2,000
Engineering	\$ 1,500
Modeling	\$ 2,500
Footers	\$ 3,000
Lighting	\$ 4,500
Installation	\$ 3,500
Contingency	\$ 14,000
<b>TOTAL</b>	<u>\$ 200,000</u>

\*\* PLEASE NOTE, THE ABOVE BUDGETS ARE ESTIMATED BALLPARK PRICES. IF SELECTED TO REFINER THIS SITE-RELEVANT PROPOSAL I WILL DESIGN THE ART PER YOUR AESTHETIC AND BUDGETARY PARAMETERS.



26. Sijia Chin  
Los Angeles, CA  
Total Budget: \$190,000

## SIJIA CHEN

[www.sijiachen.com](http://www.sijiachen.com) | Instagram: [@sijiachenart](https://www.instagram.com/sijiachenart)

To Whom It May Concern,

As a multi-disciplinary artist, I utilize form, scale, and light to explore the intersection of personal identity, cultural convergence, and self-determination. My works contemplate the complexity of shared heritage and regional culture, and how those influences shape our individual aspirations and community dynamics. Central to my practice is a social engagement process with a strong emphasis on inclusion and representation. I collaborate with communities to create artworks that reflect both personal narratives and collective experiences—producing site-specific installations that serve as dynamic, multicultural labyrinths containing layers of context and detail.

My public works are studies of the perpetual duality of our natural state, they are representations of the friction and equilibrium between individuality and community, creativity and tradition, aspiration and humility. My process involves reconstructing natural objects, landscapes, and architectural elements, and infusing them with public-sourced materials and information, visual narratives, abstract elements, and figurative images.

I have extensive experience collaborating with city agencies, landscape architects, general contractors, engineers, and fabricators to deliver projects from concept to installation. My public artworks have been commissioned to serve as gateway markers, placemaking, functional seating and play elements, and points of cultural resonance. My works including *SWA*, *Bloom*, *Blossom*, *Endeavor*, *Cloud Field*, and *New Dawn* demonstrate my ability to design and deliver large-scale, dynamic, and durable installations that are responsive to context and grounded in community dialogue.

My intent is to create a site-specific work that fulfills the project's mission, activates Fire Station #5 with a dynamic and immersive three dimensional work, and reflects the cultural heritage and themes representative of City of Denton. My concept for your project would also incorporate papercut art inspired perforations, which is recurring motif in my works. Public engagement will be essential in developing and finalizing elements of the final design of the perforations. As I have done for my completed public works *SWA*, *Bloom*, *Blossom*, *Endeavor*, *Cloud Field*, and *New Dawn*, I would organize a holistic program of community events, townhall style meetings, and papercut workshops. A key component of the workshops will be to solicit from the community their responses to a curated list of questions related to the project's theme, which I will then translate visually into figurative images and patterns through the perforations. Additionally, participants will have the opportunity to create their own papercut designs during the workshops, so that they can potentially be incorporated into the final design of the artwork. A designated website would serve as a platform for the public to submit their ideas and designs throughout the community engagement phase. This direct community participation and contribution to the development of the artwork ensures it is representative and site-specific. The project becomes more than an artistic composition, it is a collection of personal and communal ideas, narratives, and memories, and is the culmination of a community movement.

I welcome and hope for the opportunity to present and expand further on my concept for your project, thank you for your time and consideration.

Sincerely,



Sijia Chen



**CITY OF DENTON  
FIRE STATION 5  
PUBLIC ART PROJECT**

**SIJIA CHEN STUDIO**

**LIFE TOWER  
CONCEPT RENDERING**







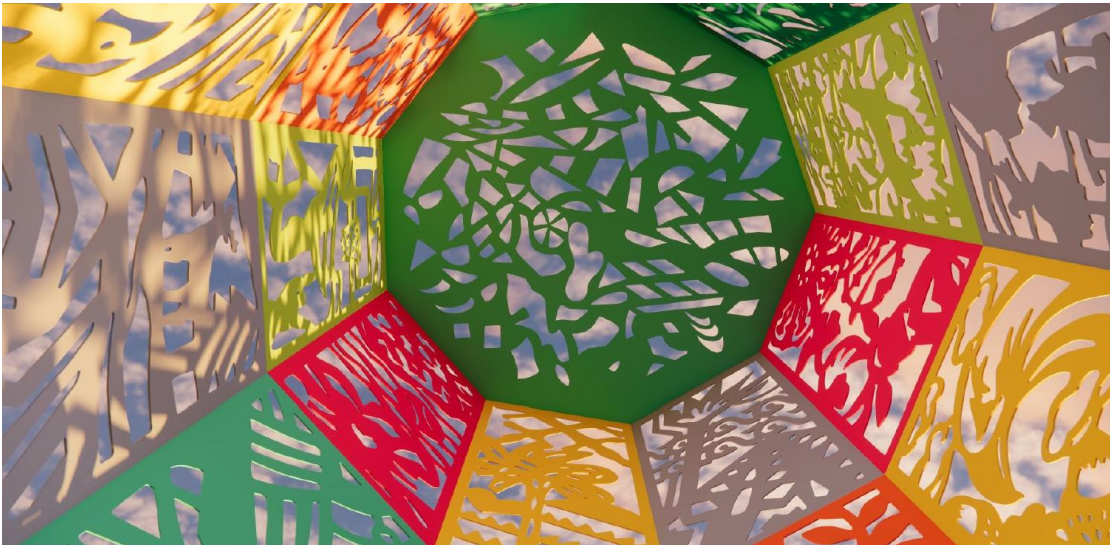

**Ceiling: Dichroic glass that shifts color depending on the viewing angle**





- Stainless steel, automotive grade fluorocarbon paint, UV resistant and anti-graffiti coating
- Height: Approx. 25ft
- Diameter: Approx. 9 ft

## PANEL DESIGN



### PROJECT BUDGET

Description	Amount
Design & Fabrication Labor	\$70,000
Materials	\$30,000
Shipping & Installation	\$10,000
Engineering Review & Site Plan	\$10,000
Site Construction	\$30,000
Travel, Insurance, Administrative Costs	\$5,000
Artist Fee	\$25,000
Contingency	\$10,000
<b>Total</b>	<b>\$190,000</b>

27.Sonarta LLC / Shahla Rahimi Reynolds  
Los Angeles, CA  
\$181,000

## CONCEPT NARRATIVE/ARTIST STATEMENT

- Firefighters have a deep respect for combustion. Sometimes flames will seem to be a living entity, something with a distinct and independent existence. No two fires are the same: from how it starts, where it goes, and how intense its heat and its destructive presence can be. It must be faced and conquered to preserve life and counter the inherent destructiveness that exists
- These public servants are regular people that are subjected to extraordinary circumstances. Their efforts reflect the heroic nature of the job, the essential dedication to a tradition of going beyond the ordinary.
- This sculpture embodies the personal attributes and attitudes that must be an integral part of meeting the challenge. The figure deftly manipulates the fire hose and fire ax as they transform it into tools that serve to tame the fiery threat. It is essential to confront and overcome this force to safeguard lives and mitigate the inherent dangers. It is a lasting reminder to the public and the firefighter of the real trials and potential risks that await in the next encounter.

## WHEN THE MOMENTS COUNT

PRESENTED BY SONARTA LLC  
BY  
SHAHLA RAHIMI REYNOLDS  
CYRUS REYNOLDS

**"WHEN THE MOMENTS COUNT"**



**“WHEN THE MOMENTS COUNT”**

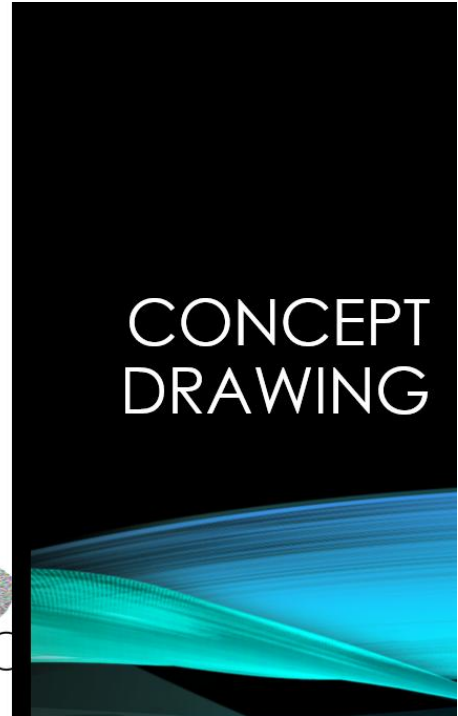
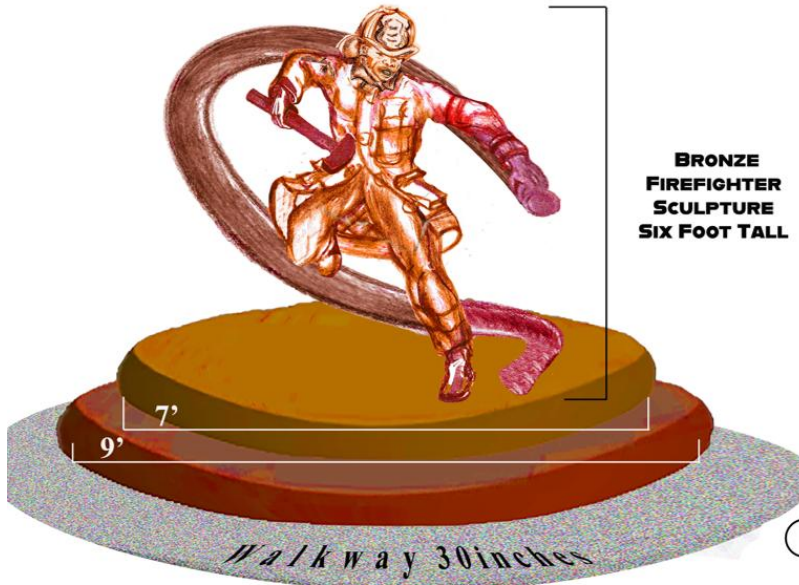

**Sonarta LLC Studio Fire Station 5, Public Art Project  
Proposed Budget**

<b>Artist Design Fee</b>	
Preliminary Design	\$ 32,000
Design Development	
Shop Drawings and Contract Documents	\$ 3,000
<b>Professional Consultation Fees</b>	
Professional Engineer licensed in the State of Texas Architect	\$ 5,000
Fire Expert Consultant Fee	\$ 5,000
<b>Administrative Expenses</b>	
Travel	\$ 8,500
Studio expenses	\$ 3,500
<b>Photography and Documentation</b>	
Copyright registration fee	\$ 8,000
Photography of work in progress	
<b>Casting and Transportation Costs</b>	
Total cost for sculpture casted and delivered	\$ 65,000
<b>Installation</b>	
Labor, Equipment, Traffic barriers, City permits, etc.	\$ 4,000
Base, Landscaping, Removal, Electrical modifications	\$ 23,000
<b>Insurance</b>	
Artwork, General Liability, Texas Worker's Compensation Automotive Liability Transportation Coverage	\$ 1,000
<b>Contingency</b>	\$ 23,000
<b>TOTAL</b>	<b>\$181,000</b>



28. Mirek Struzik  
Wroclaw, Poland  
Total Budget: \$70,000+ (?)

## Artist Statement

I have previously completed successful projects in the public realm, ranging from public parks, through botanic gardens, to large shopping malls. I am especially fascinated by the floral patterns, such as constructions of flowers and plants and the topic of transplanting floral motifs from micro to macro scale.

The defining aspect of my art is its ability to transform itself at dusk and present the nature transposed from a micro to macro scale through use of biomimicry. My series of sculptures created for parks and gardens were also based on naturalistic design principles and were designed to amplify the effects of natural light.

When the sun sets, the dynamic illumination systems built in my sculptures let them undergo a complete metamorphosis, completely changing their character. It's a great feature in dynamic public places, where a lot of people walk. As my Bubble Forest in Nice, France proved, my art also serves as perfect landmarks that make navigation in the area easier. It also works interactively, as an attractive selfie spot.

In my past projects, I have successfully collaborated with managers and general constructors of large buildings, consulting professionals and several fabricators. Some projects I have done include coordinating with civic professionals on the municipal level. My artworks are engaging pieces that carefully fit, without necessarily seeming so, into their spaces by using a creative logic.

I usually hire local companies to prepare concrete foundations and electric infrastructure for my sculptures.

Most importantly, I believe that it is key for public art projects to create meeting spots, gathering places. I always design my sculptures to be attractive selfie spots and recognizable landmarks, so they serve a very practical purpose of defining the space around them and building a sense of ownership in the community. This way, they become local attractions and are used by the people in everyday life and conversations. "Let's meet at the Bubble Forest" or "Let's meet at the Dandelions" are phrases commonly used in Nice, France or Kirkland, Wa.

Best regards,  
Mirek Struzik



Proposal Images









# Resume

## Mirek Struzik

e-mail: [ms@struzik-art.com](mailto:ms@struzik-art.com)

www: [www.struzik-art.com](http://www.struzik-art.com)

mobile: +48 692 168 278

address: ul. Ćwiczebna 9/11

51-180 Wrocław

Poland

Mirek Struzik was born in 1956 in Żarów, Poland. In 1989 he graduated from the Academy of Fine Arts in Wrocław in the department of graphics, painting and sculpture - sculpture specialty. Master of fine arts. Before gaining the degree, he worked for 8 years in design studios where he got a few invention patents. Besides that, he also studied industrial design.



### *Sculptures in public spaces*

- 2025 *Bubble Trees in the Sky*, Texas A&M University, Collage Station, TX, USA
- 2024 *Jellyfish Shrub*, Academia Sinica Tainan, Taiwan
- 2023 *The Roots of the World*, Stockholm, Sweden
- 2021 *Bubble Trees*, Neuchatel, Switzerland
- 2020 *Soaring Higher*, Wrocław, ECM hq building, Poland
- 2020 *Dandelions*, Kirkland, Wa, USA
- 2020 *Dandelions*, Dallas, TX, USA
- 2019 *Dandelions*, San Mateo, California, USA
- 2019 *Bubble Forest*, Nice, Saint-Laurent-du-Var, CAP 3000, France
- 2019 *Dandelions*, Nice, Saint-Laurent-du-Var, CAP 3000, France
- 2019 *Dandelions*, Cracow, Poland
- 2018 *Dandelions*, Seoul, South Korea,
- 2017 *Dandelions* near Burj Khalifa, Dubai, United Arab Emirates
- 2017 *Walk for the Municipal Tolpa Park*, Wrocław, Poland
- 2015 *Dandelions* for Zorlu Center, Istanbul, Turkey.
- 2012 *Dandelions* in front of the „Integart” office building, Błonie near Wrocław, Poland
- 2011 *Butterflies, Birds and Leaves* for Futura Park in Cracow, Poland
- 2011 *Director Stanislaw Lenartowicz memorial*, Wrocław, Poland
- 2010 *Memorial of Gratitude to World War II Victims*”, Opoczno, Poland
- 2008 *Splinters* for the Factory Outlet II in Wrocław, Poland
- 2007 *Adam and Eve* for the Skokie Northshore Sculpture Park, Chicago, USA
- 2007 *Shawl and Wardrobe* for the Factory Outlet in Lubon n. Poznan, Poland
- 2006 *Roots and Composition* for the Factory Outlet in Wrocław, Poland
- 2004 A project and realization of the St. Hedwig’s Chapel for Caritas of Archdiocese, Wrocław, Poland
- 2001-4 A cycle of sculptures for the Municipal Botanic Garden of Wrocław University, Poland

1989 *Force of Nature* in front of the „Centrostal” office building, Wrocław, Poland

### *Prizes and awards*

2024 Virginia Sinus Center, York Street Building, Norfolk, VA, USA  
2024 Tonglueo Campus Entry Gate Sculpture, Hsinchu Science Park, Taiwan  
2024 Dunwoody Georgetown Public Art Sculpture, Dunwoody, Georgia, USA  
2024 Fresno Yosemite International Airport - Suspended Sculpture, Fresno, CA, USA  
2023 Academia Sinica Center in Southern Taiwan Public Art Sculpture Competition  
2023 Innovative Learning Classroom Building Public Art Competition, Texas A&M University  
2023 LAGI 2022 Mannheim – Beautiful Forms of Energy – honorable mention  
2020 International Sculpture Center - November/December 2020 Featured Artist - Outdoor & Public Art Category  
2020 Awarded a Platinum A' Design Award in Arts, Crafts and Ready-Made Design Category for Bubble Forest  
2020 Recognized as one of the top artists in the 25 Creative Revolutionaries by CODAWorx  
2018 Honorable Mention Award, Circle Foundation for the Arts  
2013 Special Commendation in Nanjing International Sports Sculpture Competition For Youth Olympic Games  
2013 Finalist in “Concurso Internacional de Escultura Urbana” “Ciudad de Murcia”, Spain  
2013 Sculpture “Dandelion” chosen to “Top 100” of CoD+A Awards in Public Art category  
2012 1st prize for commission, appointed by the City of Ballart’s Public Art Advisory Committee, Australia  
2011 1st prize in public art project competition for Futura Park, Krakow, Poland  
2009 1st prize in public art project competition for „Memorial of Gratitude to World War II Victims”, Opoczno, Poland  
2007 First prize in competition of sculpture realization for Factory Outlet in Luboń near Poznań, Poland  
2006 First prize in competition of sculpture realization for Factory Outlet in Wrocław, Poland  
2005 Sugarman Foundation Award, USA  
2001 3rd prize in competition „Sacrum – dzisiaj” Kielce, Poland  
1990 Scholarship from the Ministry of Culture and Arts, Poland

### *Participation in exhibitions*

2023 BUGA 23 – participation in the exhibition of select designs from the LAGI 2022 competition, Mannheim, Germany  
2020 Participation in The Landscape of Form exhibition at Baker-Howard Contemporary, London  
2020 Participation in the *Genius Loci* exhibition in the municipal museum of Jelenia Góra  
2019 *The ARTBOX.PROJECT Miami 2.0* at the ART BASEL MIAMI ART WEEK 2019  
2018 *K-Lab Land Art Biennale Norway*  
2015 *Istanbul Light Festival Istanbul, Turkey*  
2015 *6th International Art Biennale, Beijing*  
2015 *Beauty of Animals - Global Art Medal Grand Prix, China*  
2013 *9th International Sculpture Symposium, Davos, Switzerland*  
2013 Post-competition exhibition, *Concurso Internacional de Escultura Urbana Ciudad de Murcia, Spain*  
2013 *25th International sculpture Biennale, Ube, Japan*  
2012 *European Sculpture Exhibition, Stockholm*  
2012 *Art. Expo, New York*  
2012 *Premio Internazionale Tokyo, Galeria Amart Luise, Bruxelles, Belgium*  
2011 *European Sculpture: methods, materials, poetry, Edsvik Konsthall, Stockholm*  
2011 *1st International Wood Symposium, Gangel, Germany*  
2011 *Premio Internazionale Tokyo, Galery Amart Luise, Bruxelles, Belgium*  
2010 *Open Art Code, GemlucArt, Monte Carlo, Monaco*  
2010 *Open Art Code, GALLERY@OXO, London, UK*  
2009 *Sculpture in Context, National Botanical Garden, Dublin, Ireland.*  
2008 Exhibition for the 100th anniversary of Hungarian Polonia in Budapest, Hungary  
2008 *World Art Vision in Cancun, Mexico*

## Publications

- The Economic Power of Public Art, CODAworx, 2024
- Informator Polish Artists' Association Magazine #55 03/2023
- Land Art As Climate Action, editors: Elizabeth Monoian and Robert Ferry, 2023
- Rzeźby w przestrzeni publicznej, Decoration & Design magazine, 4 (55) 2021
- Meet me at the Dandelions, [Kirkland Lifestyle](#) Feb. 2021
- International Sculpture Center - November/December 2020 Featured Artist - Outdoor & Public Art Category
- Making Money and Creating Community with Monuments, Jeremiah Karpowicz, 2020, USA, page 78-79
- Award Winning Communication Design Yearbook 2019-2020, ISBN Number 978-88-97977-38-4, page 33
- Sculpture Network, "Wood – a material for old and new"; June 2020; <https://bit.ly/38d3PdQ>
- Sculpture Magazine May/June 2020
- [ThyMagazine.it – A' Design Awards & Competition Winners 2020](#)
- [Creative Boom - World's largest design contest, the A' Design Awards, announces 2020 winners](#)
- CODAworx, 25 Creative Revolutionaries 2020, <http://codaworx-5964602.hs-sites.com/creative-revolutionaries-2020>
- Fenomen Polska magazine, 3-4/2019, Made in Poland, Designed by Mirek Struzik – a profile of the artist
- CODAmagazine, The Magic of Color VI, 2019 <https://www.codaworx.com/project/bubble-forest-altarea>
- CODAmagazine, Video III, 2018
- Polish Market Special Edition 2018
- CODAmagazine, Light as Art V, 2018, <http://fiip.it/yMsdWT>
- Sculpture magazine, October 2016
- CODAmagazine, Light as Art III, 2016 <http://fiip.it/fE9IH>
- Memory and Dream 2015 - The Album of 6th Beijing International art Biennale, China
- Hephaistos magazine No 7/78 2013
- Land Art Generator Initiative (LAGI) Catalog, Freshkills Park, NYC 2012
- Art in Vogue 2012 (coming now)
- World of Architecture No7 2011 (polish edition)
- 500 x art in public, Braun Publishing 2011
- World Wide Art Book 2010
- Featured artists vol. II 2010
- Land Art Generator Initiative (LAGI) Catalog, Dubai & Abu Dhabi, UAE 2010
- Masters 2009
- Trends Contemporary Artists 2009

29. Studiofolia/James Dinh  
Cerritos, CA  
Total Budget: \$175,000



**James Dinh**

**Resumé**

12723 Park Street  
Cerritos, CA 90703  
562.841.2512  
james@studiofolia.com  
www.studiofolia.com

**EDUCATION**

Master of Landscape Architecture, University of California, Berkeley  
Master of Public Health, with a concentration in epidemiology, University of California, Los Angeles  
Bachelor of Science in Biological Sciences, University of California, Irvine

**WORK EXPERIENCE**

2014 – present Principal  
Studiofolia, Cerritos, CA

**PUBLIC ART COMMISSIONS**

Current      Leinberger Memorial Center public art, Woodland, CA – completed  
Montgomery County Law Enforcement Memorial, Dayton, OH – under construction  
September 11 Memorial, Indio, CA – under construction  
North Valley public art, Reno, NV – under construction  
Bitter Lake Reservoir public art, Seattle, WA – in design development  
Villa Chiquita Park public art, Mountain View, CA – in design development  
Willie Henderson Sports Complex public art, San Diego, CA – in design development  
Community Resource Center public art, Surprise, AZ – in design development, with Mandy Palasik  
New Mexico Tech public art, Socorro, NM – in design development, with Mandy Palasik  
Quincy Jones Square public art, Bremerton, WA – under construction, with Michael Stutz  
Oakey Dog Park public art, Las Vegas, NV – in design development, with Michael Stutz

2024      Baltimore County COVID-19 Memorial, Baltimore, MD – completed  
Higuera Adobe public art, Milpitas, CA – completed

2023      Vista Canyon Multi-Modal Center public art, Santa Clarita, CA – completed  
50th Anniversary sculpture, Cedar Park, TX – completed  
Commemorative public art, Frankfort, KY – completed  
Sports Park mural, Tustin, CA – completed  
Woman's College tribute, Uni. of N. Carolina, Greensboro – completed with Michael Stutz  
2024 CODA awards Winner, Education category  
Kahului Community Park mural, Maui, HI – completed with Thinh Nguyen

2022      St. Thomas University student memorial, St. Paul, MN – completed  
University of Nebraska public art, Lincoln, NE – completed  
Westminster Crossing affordable housing art, Westminster, CA – completed with Thinh Nguyen

2021      Evergreen Cemetery Veterans Memorial, Gainesville, FL – completed

2020      Equity Fountain public art, Helena, MT – completed with Michael Stutz

2018      Art in Transit Program, bus shelter public art, San Antonio, TX – completed  
National Native American Veterans Memorial, Smithsonian, Washington D.C. – finalist

2017      Of Two Lineages public art, Westminster, CA – completed

2016      David & Margaret Youth and Family Services Public Art, La Verne, CA – completed



# studiofolia

2015 LA County Sheriff's Memorial, LA County Arts Commission – commissioned artist

2014 Circles of a Ripple public art, Hacienda Heights Community Center – completed

## SYMPOSIUMS / LECTURES

2023 Webinar: *Representation: the Crux of Public Space*, World Heritage USA  
The webinar pushes the activism of creators into the forefront, featuring guest speakers from the United States of America and Afghanistan.  
<https://www.youtube.com/watch?v=MmYqfaqqZng>

## EXHIBITIONS & WORKSHOPS

2018 *Viet Stories: Recollections & Regenerations*, Richard Nixon Library, CA – exhibition designer

2017 *Impress*, Orange County Center for Contemporary Art – participating artist

2016 Coastal Communities Cancer Center Temporary public art, Ventura, CA – commissioned artist

2015 Earth Day Temporary Public Art Installation, City of Garden Grove, CA – commissioned artist  
*40 Hues Between Black & White*, Orange County Center for Contemporary Art – participating artist  
Re:Imagine Garden Grove, Garden Grove, CA – participating artist for community workshop

## AWARDS

2019 Orange County Arts Awards Honoree: Achievement Award for Arts Leader

2017 American for the Arts Convention Scholarship

2006 Post-Katrina New Orleans East Design Residency, New Orleans, LA

## REFERENCES

Erik Qvale  
Public Art Manager, Los Angeles Metro  
807 N. Edgemont St., Los Angeles, CA 90029  
E: [QvaleE@metro.net](mailto:QvaleE@metro.net)  
T: 213-999-3336

Meagan Dion  
Nebraska Public Art & Artist Programs Specialist  
1004 Farnam Street, Omaha, NE 68102  
E: [Meagan.Dion@nebraska.gov](mailto:Meagan.Dion@nebraska.gov)  
T: 402-595-2122

Katherine Nestved  
Arts and Events Coordinator, City of Santa Clarita  
23920 Valencia Blvd., Santa Clarita, CA 91355  
E: [KNestved@santa-clarita.com](mailto:KNestved@santa-clarita.com)  
T: 661-565-0588

Dear Selection Committee:

It is an honor to submit my interest and preliminary design concept for the Denton Fire Station public art project. Based in Los Angeles County, I founded the collaborative design practice Studiofolia in 2014 with the simple mission of designing public art spaces that connect people to memory and place. Because the context and requirements of each project are different, my design process is based on an *approach* rather than a singular style or medium. This focus on site-specificity is reflected in the diversity of my built projects in different communities across the country. Each project tells a story that is unique to its place.

I am drawn to the Denton Fire Station public art project because I believe the selfless service of firefighters and first responders should be honored and recognized. Having completed large-scale, community-centered artworks across the country, I believe that my experience working with different stakeholders and engaging diverse communities will make me a strong candidate for this project.

#### Design Concept: Tower of Service

The tower-like shape of the proposed sculpture is inspired by fire lookout towers, which were once found in cities, but are now mostly seen in wilderness areas. Like the lookout towers, the artwork is intended to be a beacon for the community that recognizes and celebrates the work of fire fighters.

Made of steel panels, the sculpture stands about 16 feet tall and 4 feet wide. Each of the sculpture's four sides contains four medallions of the St. Florian Cross, which is an ancient symbol that represents fire fighting departments around the world. Each side also contains cut-out text of a "core value" of the Denton Fire Department: respect, integrity, courage, and humility.

In the center of each medallion are images of things that are associated with fire fighting, such as axes, hoses, hydrants, extinguishers, etc. The artist will work with the fire station staff to determine the fire-fighting objects that are represented in each circular medallion.

One in-ground LED light can be placed in the middle of the base of the sculpture. Normally lit a red color at night, the light can change to blue when fire fighters respond to emergencies. The sculpture is envisioned to be painted the same iconic red color as fire trucks. A highly durable industrial paint such as Tnemec or Carboline Carbothane can be used.

The design shown in this proposal is intended to be preliminary and conceptual. The artist anticipates that the design will be enriched and evolve with continual feedback from stakeholders. The artist will work with the fire station staff and the city to determine the most visible and appropriate location for the sculpture. Thank you for your consideration

Sincerely,

James Dinh  
Studiofolia

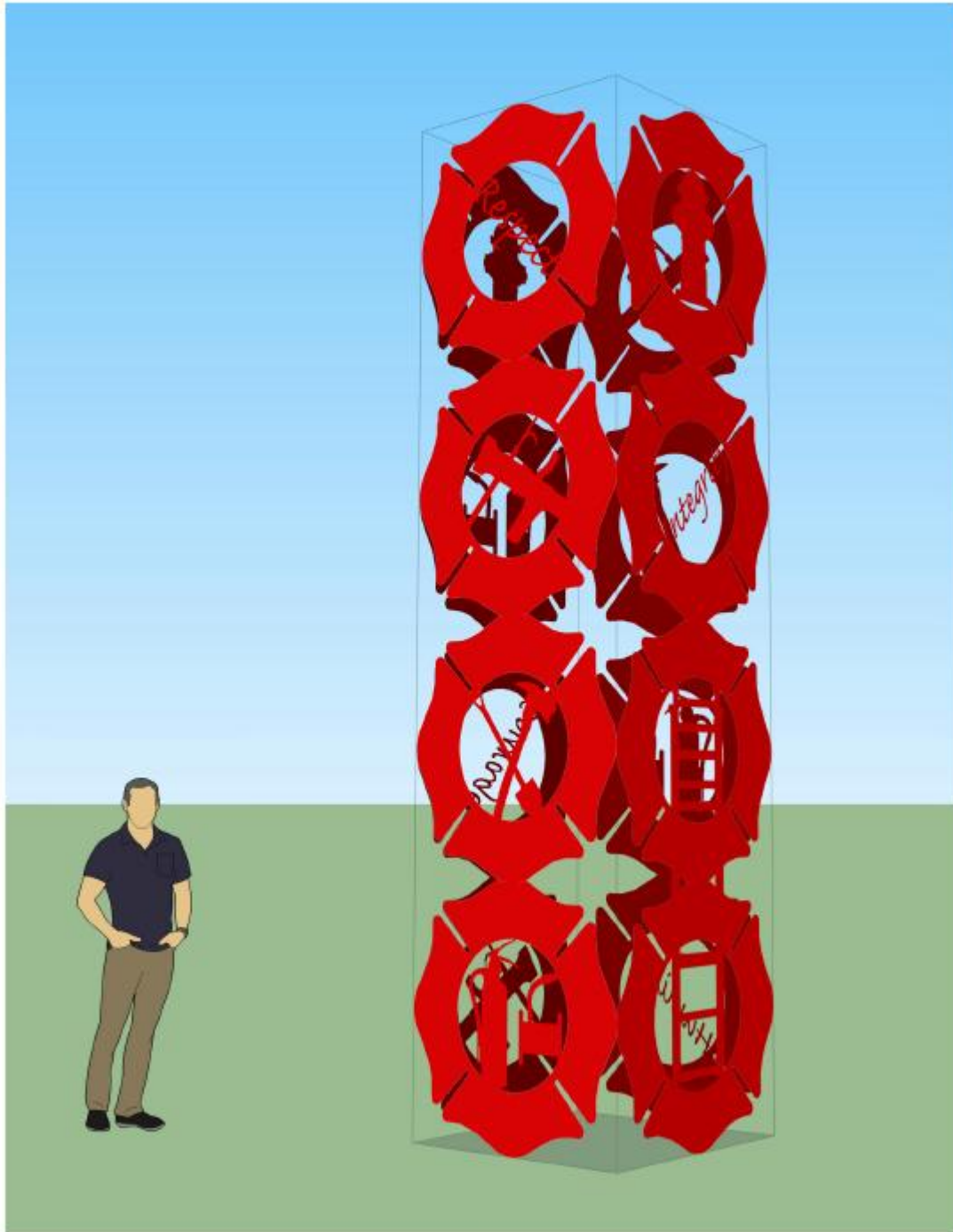

Elevation view of each side of the proposed sculpture. The artist will work with the fire station staff to determine the fire-fighting objects that are represented in each circular medallion.





Item	Cost
DESIGN	
Artist fee (~12.5%)	22,000
Computer modeling / drawings	6,000
Structural engineer	6,000
Travel	6,000
OFF-SITE WORK	
Sculpture materials & fabrication	75,000
Shipping	6,000
ON-SITE WORK	
Concrete footing	20,000
Installation	10,000
Lighting (1 in-ground LED fixture)	6,000
CONTINGENCY (~10%)	18,000
<b>TOTAL</b>	<b>175,000</b>

Note: Budget does not include site prep  
or electrical service conduits to the artwork

30. SV Randall Studio  
Dallas, TX  
Total Budget: \$

SV Randall

3/20/2025

# City of Denton Parks and Recreation Department FIRE STATION # 5

\* PRELIMINARY DESIGN PROPOSAL

#5 RFP-8773



City of Denton - Fire Station # 5

# Preliminary Design Proposal

#5 RFP-8773



01 Design

02 Budget

01 Maintenance

04 Timeline

05 Resumé

06 Portfolio

# VISION

My aim for this project is to create engaging and beautiful piece of sculptural artwork that will captivate the interest of the City of Denton residents for the long-term.

01 Design

02 Budget

01 Maintenance

04 Timeline

05 Resumé

06 Portfolio

# DESIGN GOALS

My aim for this project is to create engaging and beautiful piece of sculptural artwork that will captivate the interest of the City of Denton residents for the long-term. This sculpture was designed with 3 primary goals in mind:

**Honor and Inspire:** To celebrate the heroism of firefighting in Texas and the United States, recognizing not only the bravery and sacrifice of firefighters but also the deep sense of community, resilience, and service they embody. The sculpture seeks to stand as a lasting tribute, inspiring pride and gratitude in all who encounter it.

**Dynamic Perspective:** The sculpture is designed to be interesting from all angles, allowing for maximum enjoyment to residents, whether they are walking or driving by.

**Stylized Representation:** The sculptures exist in a playful space between abstraction and representation in order to evoke rather than directly depict.

01 Design

02 Budget

01 Maintenance

04 Timeline

05 Resumé

06 Portfolio

Design 1A - "Ever Vigilant"

Rendered here at 12 x 16 feet



<b>01</b> Design	<b>02</b> Budget	<b>01</b> Maintenance	<b>04</b> Timeline	<b>05</b> Resumé	<b>06</b> Portfolio
------------------	------------------	-----------------------	--------------------	------------------	---------------------

Design 1B - "Ever Vigilant"





Rendered here at 12 x 16 feet



<b>01</b> Design	<b>02</b> Budget	<b>01</b> Maintenance	<b>04</b> Timeline	<b>05</b> Resumé	<b>06</b> Portfolio
------------------	------------------	-----------------------	--------------------	------------------	---------------------

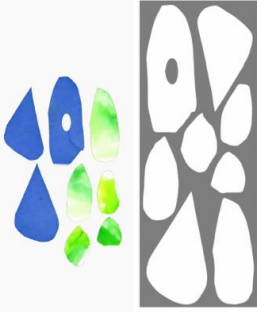

# FABRICATION PROCESS

Digitize	Cut	Assemble	Paint		
<p>Create vector files of shapes</p> 	<p>Mill shapes using water jet CNC</p> 	<p>Bend and weld</p> 	<p>Sandblast, prime, paint, and clearcoat</p> 		
01 Design	02 Budget	01 Maintenance	04 Timeline	05 Resumé	06 Portfolio

# FABRICATION COMPANY - OPTION 1

## Decotron

- Dallas based / Excellent track record working on public art projects in DFW
- Turn key service, all in-house: Engineering, Fabrication, Transportation, Foundation and Installation

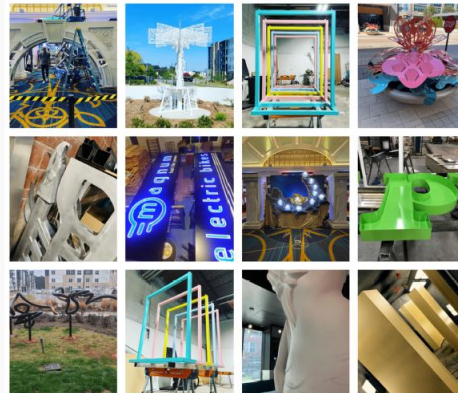

01 Design	02 Budget	01 Maintenance	04 Timeline	05 Resumé	06 Portfolio
-----------	-----------	----------------	-------------	-----------	--------------

# FABRICATION COMPANY - OPTION 2

## Wanderlust

- San Antonio-based / Excellent track record working on public art projects in DFW
- Fabrication, Storage, Delivery - No Installation, No Foundation, and No Engineering

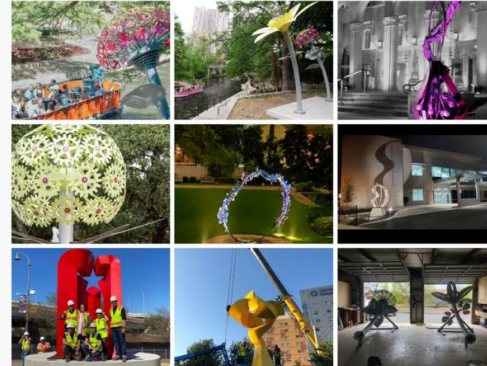

01 Design	02 Budget	01 Maintenance	04 Timeline	05 Resumé	06 Portfolio
-----------	-----------	----------------	-------------	-----------	--------------

### Tentative Budget Overview

Turn Key Engineering, Fabrication, Transportation, Foundation and Installation - Decotron (Dallas, TX)	
<b>Structural Engineering, Fabrication, Transportation</b> - Materials, CNC cutting services, labor, transport, rigging	\$98,000
<b>Foundation + Installation</b> Site prep (excavation and grading if needed) and concrete footing	\$24,000
<b>Permits and Insurance</b> - Liability insurance, permitting, & city fees	\$4,000
<b>Artist Fee</b> (16%) - Concept design, artist labor, documentation, studio admin. and overhead	\$27,000
<b>Contingency</b> (10%) - Unexpected expenses	\$17,000
<b>TOTAL:</b>	<b>\$170,000</b>

*Pricing quotes from subcontractors are initial estimates.  
The bottom line can be lowered depending on scale of sculpture to be determined after consulting with City of Denton Public Art Committee.*

01 Design	02 Budget	01 Maintenance	04 Timeline	05 Resumé	06 Portfolio
-----------	-----------	----------------	-------------	-----------	--------------

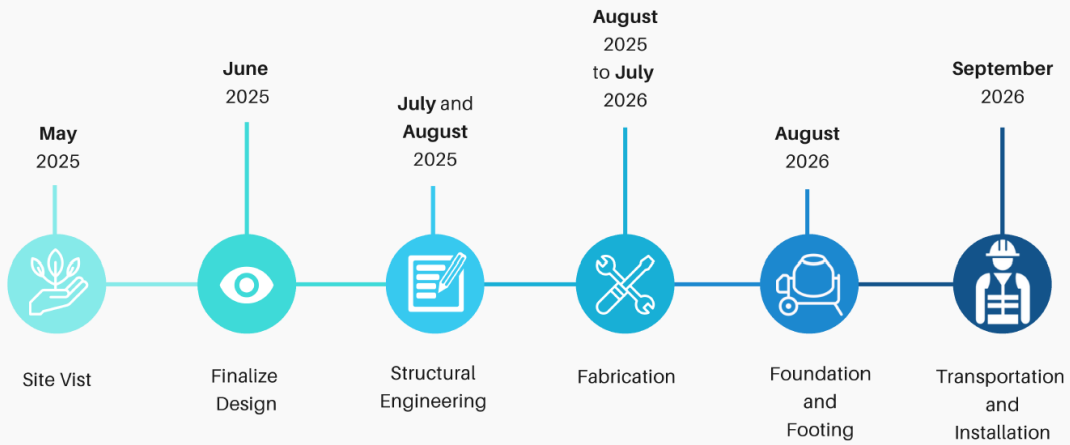

01 Design	02 Budget	01 Maintenance	04 Timeline	05 Resumé	06 Portfolio
-----------	-----------	----------------	-------------	-----------	--------------



- Stainless Steel painted with Automobile-grade epoxy paint has a life of 20+ years and requires little to no maintenance.
- Extremely low maintenance, every fabricator I've consulted with recommended power washing and spot paint touch-ups **as needed** for this combination of stainless steel & epoxy paint.

01 Design	02 Budget	01 Maintenance	04 Timeline	05 Resumé	06 Portfolio
-----------	-----------	----------------	-------------	-----------	--------------

31. Elizabeth Akamatsu / The Red Pine Company  
Nacogdoches, TX  
Total Budget: \$200,000

DENTON FIRE STATION #5  
**The Heart of the City**

Firefighters are more than first responders—they are the steady pulse that keeps our community strong, safe, and unified. Every time the alarm sounds, these courageous men and women answer the call without hesitation, prepared to risk everything to protect lives and property. Their commitment runs deeper than duty—it is an act of love, a testament to their unwavering dedication to the people they serve.

To embody and honor this immense devotion, I propose a monumental heart sculpture, fabricated from stainless steel. Towering at 12 feet tall with dimensions of 8 feet by 6 feet, this heart will symbolize the generosity, bravery, and sacrifice of Denton's firefighters. Resting upon a 12- to 24-inch tall concrete base, the sculpture will blend seamlessly into its surroundings, with its final height dictated by the landscape design. The surface may be brushed stainless steel for a sleek, reflective effect or powder-coated in a vibrant hue to further express the warmth and passion firefighters pour into their work.

If electricity is available, this tribute can become even more dynamic. Lights embedded within the sculpture could flicker when an emergency call is made—serving as a visible reminder that somewhere, firefighters are rushing toward danger on behalf of others. As the sun sets, internal lighting would illuminate the heart, allowing its presence to shine through the night as a beacon of resilience, heroism, and love for the community.

This project isn't just about a structure—it's about capturing the spirit of those who serve, ensuring their sacrifices are forever seen, felt, and honored.

Words reflecting those of a firefighters character will be laser cut out of the metal. These words can be changed to those desired by the committee.

The sculpture will be bolted to the concrete base using concrete anchor bolts.



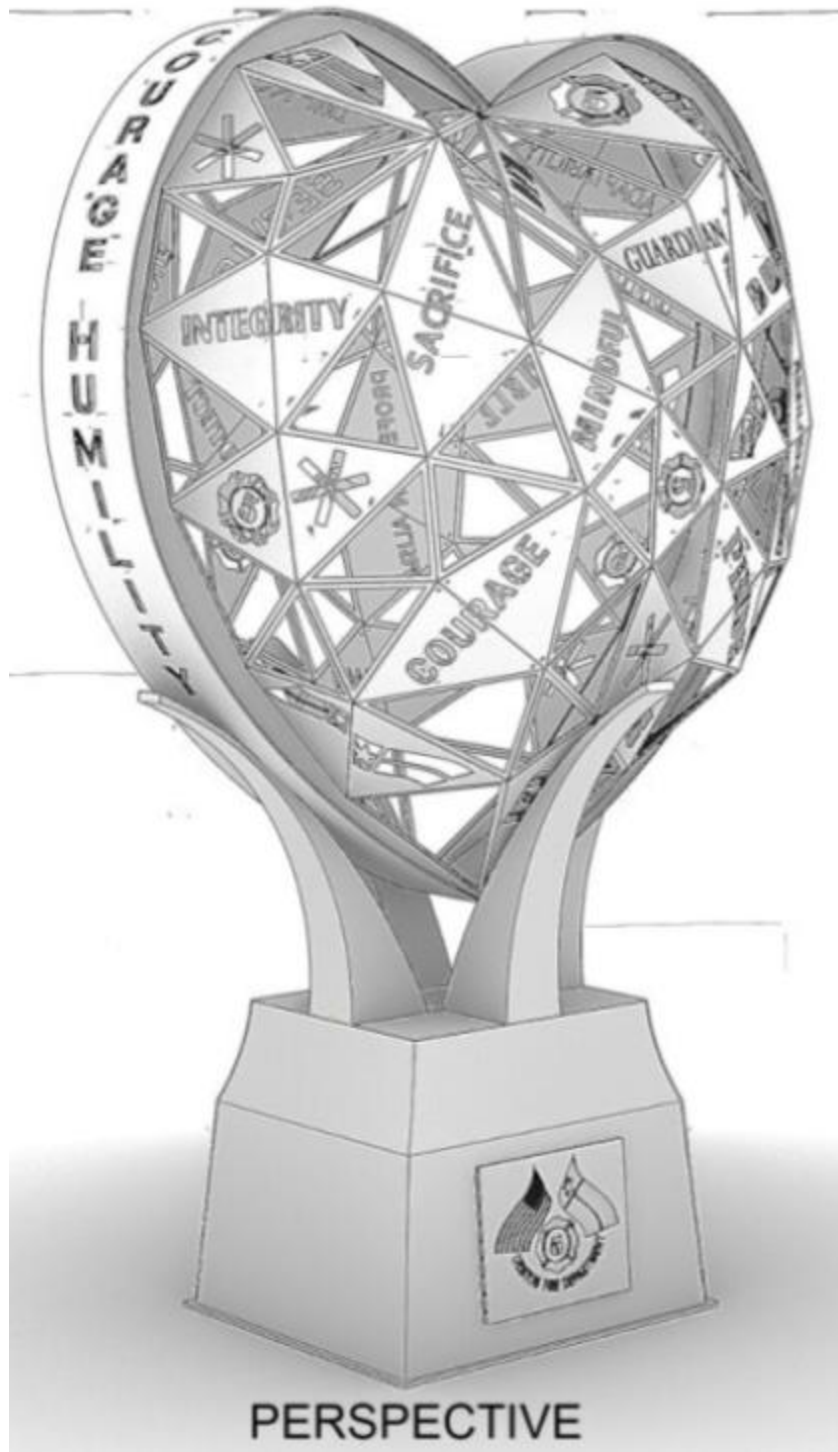

PERSPECTIVE

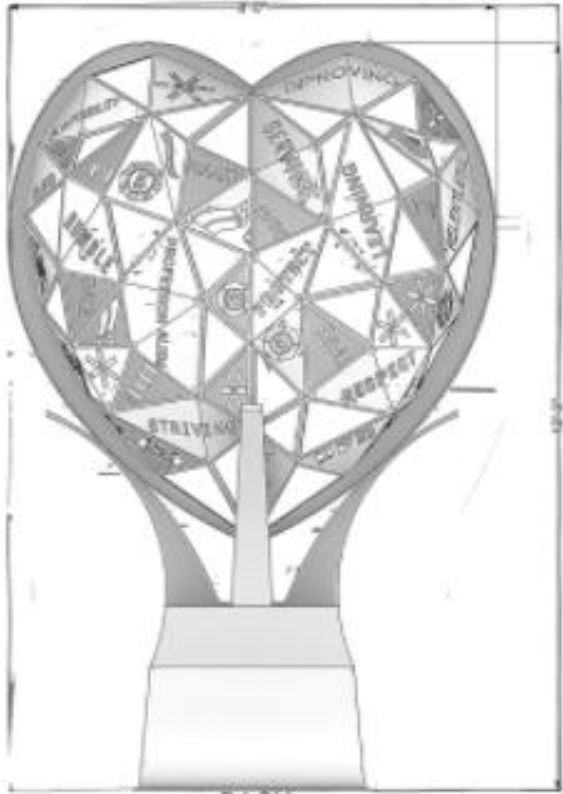

BACK



RIGHT

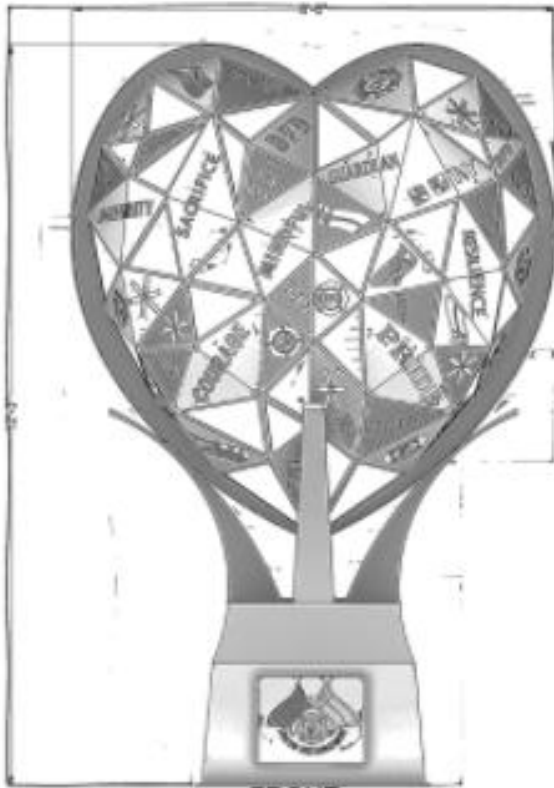

FRONT

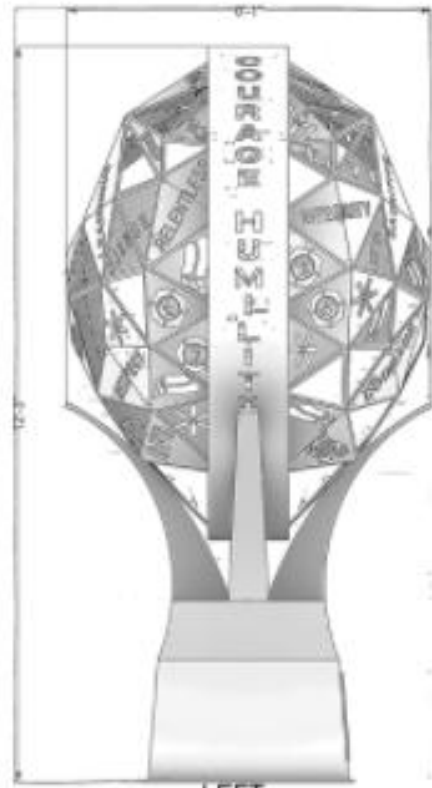

LEFT





# **FIRE STATION #6**

## **CATALOG OF PROPOSALS**



1. 220 Designs  
Manchaca, TX  
Total Cost: \$124, 180

### Overview:

The proposed artwork consists of a 7-foot stainless steel badge sculpture crafted from hand forged and textured stainless steel bar designed to be site-specific, harmonizing with its surroundings to create a unique and engaging work of art.

### Variations and Customization:

- Scalability: This sculpture can be scaled up or down to fit site location for alternative visibility options.
- Color Options: The sculpture can be powder-coated in different colors, adding vibrancy and making the piece stand out in its surroundings.
- Lighting: If required, I can design and install lighting to highlight the artwork, pending further site details and an additional proposal.

### Installation and Durability:

- Material and Fabrication: The sculpture will be constructed from brushed stainless steel, chosen for its ability to sparkle in daylight and reflect lights at night, creating a captivating visual effect. The fabrication time will be 4-6 months. Progress photos will be made to show progression.
- Maintenance: The brushed finish helps hide scratches from interaction, making the sculptures virtually maintenance-free. It will

**1 3 0 1 b l a c k b e a r , m a n c h a c a , t x 7 8 6 5 2**  
**5 1 2 . 4 1 3 . 7 6 2 5**



## Proposal for Public Art Installation at Denton Fire Station

### Fullered steel badge sculpture

#### Overview:

The proposed artwork consists of a 7-foot stainless steel badge sculpture crafted from hand forged and textured stainless steel bar designed to be site-specific, harmonizing with its surroundings to create a unique and engaging work of art.

#### Variations and Customization:

- **Scalability:** This sculpture can be scaled up or down to fit site location for alternative visibility options.
- **Color Options:** The sculpture can be powder-coated in different colors, adding vibrancy and making the piece stand out in its surroundings.
- **Lighting:** If required, I can design and install lighting to highlight the artwork, pending further site details and an additional proposal.

#### Installation and Durability:

- **Material and Fabrication:** The sculpture will be constructed from brushed stainless steel, chosen for its ability to sparkle in daylight and reflect lights at night, creating a captivating visual effect. The fabrication time will be 4-6 months. Progress photos will be made to show progression.
- **Maintenance:** The brushed finish helps hide scratches from interaction, making the sculptures virtually maintenance-free. It will

**1 3 0 1 b l a c k b e a r , m a n c h a c a , t x 7 8 6 5 2**  
**5 1 2 . 4 1 3 . 7 6 2 5**



extensive experience in metalworking, I am able to craft art that is not only visually appealing but also built to withstand the test of time.

Within my art, I employ subtle irony to present alternative viewpoints. For instance, I might design a textured steel bench that appears uncomfortable at first glance but is actually quite cozy to sit on. Alternatively, I might create oversized metal ants that invite viewers to explore their whimsical world. I believe that this approach resonates universally, even among individuals without a background in fine art appreciation. This inclusivity and accessibility are fundamental aspects of how I define public art and its purpose.

By incorporating these elements of thought-provoking concepts, meticulous craftsmanship, and a touch of irony, my aim is to enrich public spaces and encourage meaningful interactions among diverse audiences. I aspire to create public art that not only captivates but also challenges individuals, encouraging them to expand their perspectives and engage with art in a way that is both enjoyable and intellectually stimulating.

I have over 30 years of experience creating and installing complex architectural metalwork and public art. I am well versed in working with all members of the project and can deliver the project on time and on budget.

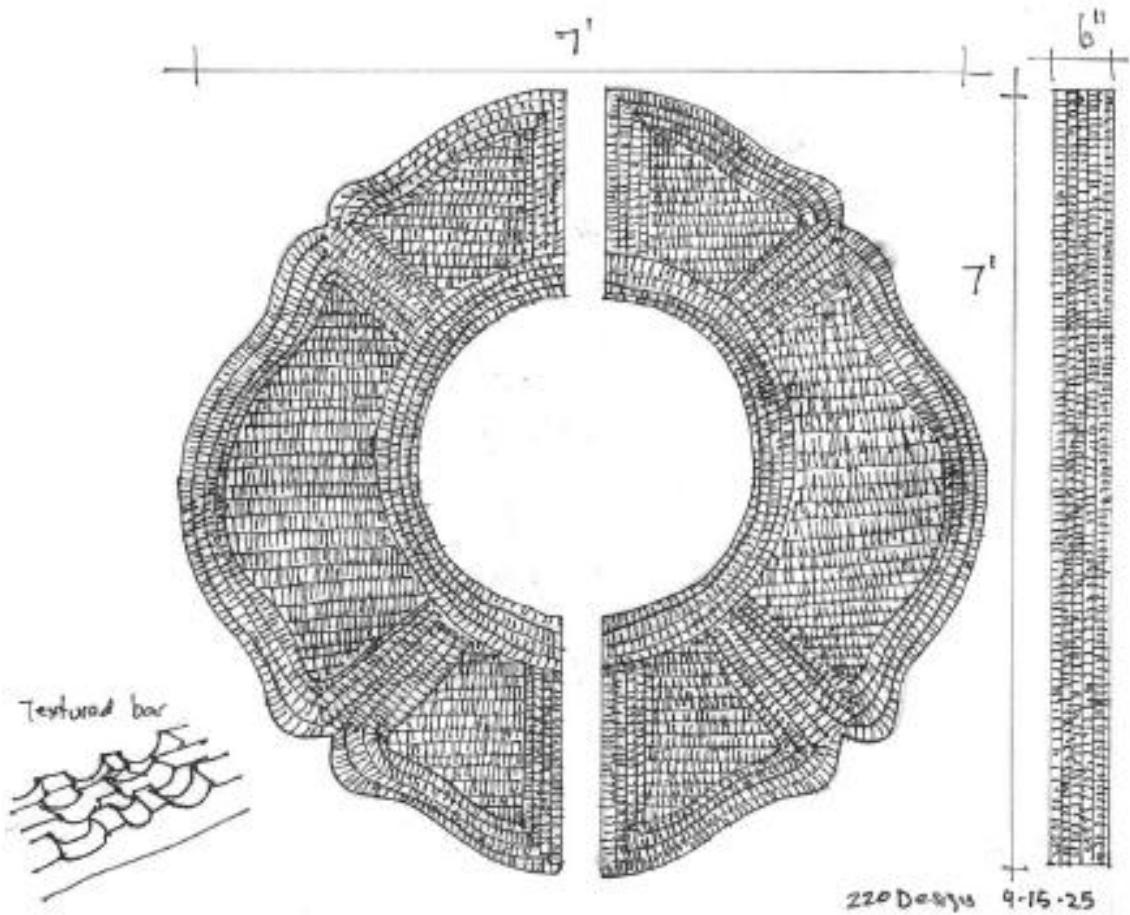



2. 900 North Studio / Alicia Eggert  
Indianapolis, IN  
Total Cost: \$160,547.22

**Spacetime Continuum**  
Proposal Statement / Denton Fire Station #6

**Alicia Eggert**

---

My work gives material form to language and time, those powerful but invisible forces that shape our perception of reality. I have always gravitated toward language as a sculptural material, and I like to think I sculpt words the way other artists sculpt clay or wood. I draw inspiration from physics and philosophy, but I use simple, everyday words as points of entry into concepts that feel are beyond my intellectual grasp. These words are accessible to anyone who can read and understand the same language, making them an approachable medium through which complex ideas can be shared.

I believe we all need more opportunities in our everyday lives to reflect on the wonders of the world we live in and the role we play in it. So that is my pursuit — to make works of art that create opportunities to reflect on what is truly important. I've found working in public space to be the best environment in which to reach and inspire a broad and diverse audience. Public art allows me to present pressing issues in ways that feel personal and sincere in spaces that are familiar, inclusive, and ideal for audiences who might not otherwise get the opportunity to encounter them.

The project at Denton Fire Station #6 is particularly meaningful to me, because Denton is my home. It's where I live and work, and where I've chosen to raise my son. As a professor of Sculpture at the University of North Texas and a former member of Denton's Public Art Committee, I am committed to the creative growth of younger generations, and to contributing to the vibrant cultural atmosphere of the city. A public art commission would allow me the rare opportunity to give back to my hometown, my community, and my neighbors.

Spacetime Continuum encourages people to reflect on the present moment and our place within it, both individually and collectively. Installed near the fire station, where time is often measured in urgency and action, the sculpture will serve as a powerful reminder of the immediacy of "now"—a moment that is constantly becoming, never static. The word NOW is elongated in space, indicating the potential to extend and spiral endlessly outward and upward in opposite directions. This gesture suggests that the present is not isolated, but an unfolding extension of the past and a bridge into the future. The sculpture fosters mindfulness and invites Denton residents to consider the continuity of time, and how each moment is shaped through awareness, attention, and action.

The sculpture's title, Spacetime Continuum, references the concept from physics that space and time are not separate entities, but interconnected dimensions that form the fabric of the universe. This idea is echoed in the sculpture's form, which visualizes time not as a fixed point but as a flowing, physical presence. By giving this concept a material form, I invite people to experience it physically, in real space and time, where it can take on new meaning through the viewer's presence, movement, and changing point of view.

The generous budget would enable Spacetime Continuum to be fabricated with the highest quality, most durable, and beautiful materials at a scale capable of reaching and inspiring a broad public audience. The sculpture will be engineered to withstand extreme weather events, intense heat and sun, and those strong North Texas winds. The fabrication process is carefully planned from the bottom up, starting with a reinforced concrete plinth poured well-below ground level. A framework

of welded steel would provide the supporting inner structure and the external form sculpted in marine-grade fiberglass. UV-resistant paint and clear coating will ensure the sculpture looks in 20 years the same it did the day of installation.

Since 2021, I've worked closely with the City of Fort Worth and Public Art Manager Michelle Thomas Richardson on a large-scale outdoor sculpture for a traffic roundabout, titled *A Very Long Now*. The 30-foot-tall, \$320,000 sculpture is now complete and awaiting transportation, and I'm thrilled to begin installation with my team during the first week of July. This project has been a massive undertaking—from early design iterations to close collaboration with the curator, structural engineer, general contractors, material vendors, and the fabrication team at 900 North Studios. Throughout the process, I've had to learn the language of multiple construction disciplines, becoming familiar with new materials and procedures along the way. This experience, combined with my personal connection to the City of Denton, uniquely positions me to create a lasting, iconic artwork that honors and inspires both the city's firefighters and its residents.

If awarded the opportunity to create *Spacetime Continuum*, I would work closely with 900 North Studios to engineer, fabricate, and install the sculpture. Based in a 20,000-square-foot facility in the heart of Indianapolis, 900 North manages every phase of production, from project management and design to engineering, fabrication, and installation. They have successfully brought to life projects for municipalities, artists, architects, private clients, and developers around the world. With extensive experience executing large-scale sculptures with budgets approaching half a million dollars, I have full confidence in their ability to deliver exceptional results with precision, professionalism, and care.

Thank you for the opportunity to submit my proposal. I look forward to the possibility of contributing to this meaningful project.

Alicia Eggert

A handwritten signature in black ink, appearing to read 'Alicia Eggert', with a long horizontal flourish extending to the right.

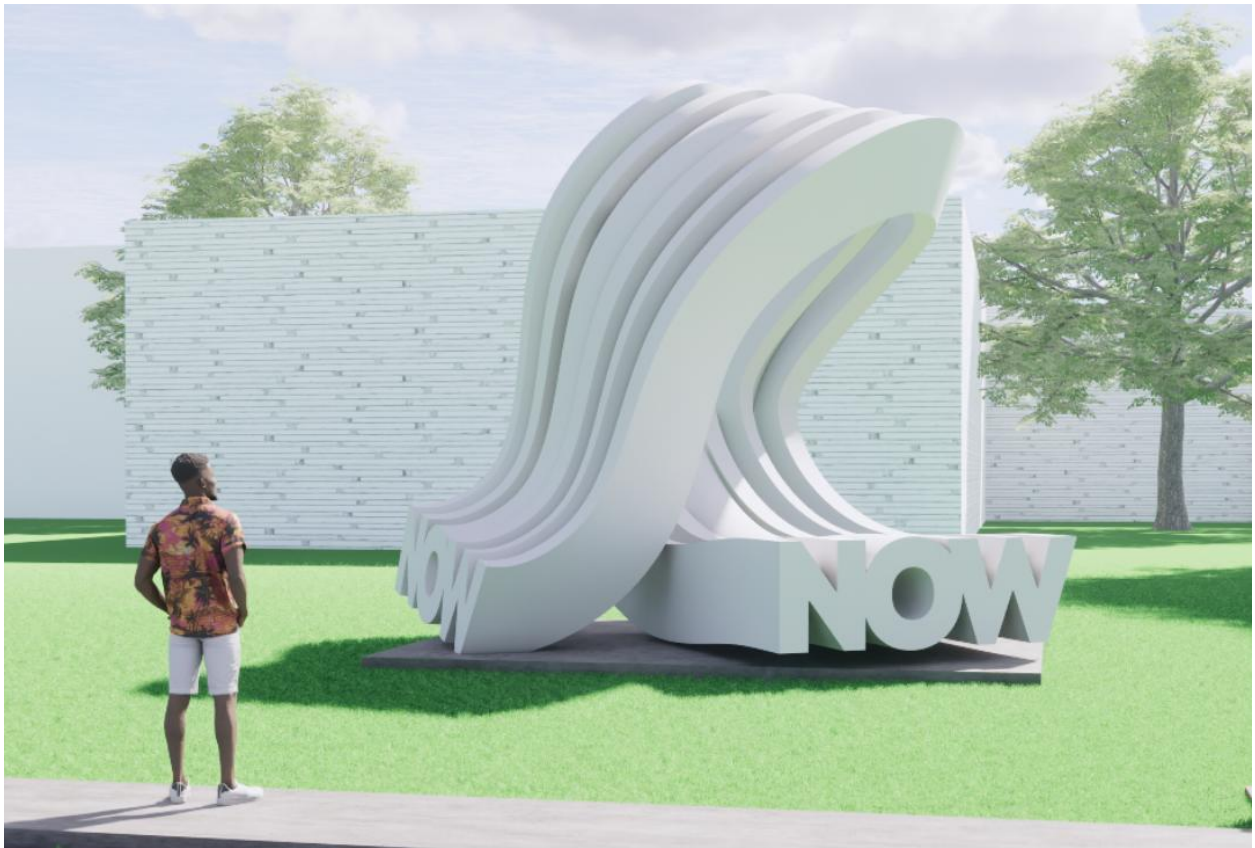





**Spacetime Continuum  
Budget / Denton Fire Station #6**

**Alicia Eggert**

---

<b>Materials</b> (steel, fiberglass, metal surface epoxy, hardware, powder coat, consumables).....	<b>\$58,452.13</b>
<b>Fabrication</b> (design, cutting, drilling, fiberglass, surface, coating, handling, welding, grinding) .....	<b>\$24,618.72</b>
<b>Engineering</b> .....	<b>\$5,000.00</b>
<b>Installation</b> (labor, concrete, transportation, rentals, airfare, lodging, per diem).....	<b>\$24,200.00</b>
<b>Artist Fees</b> .....	<b>\$37,049.36</b>
<b>Contingency</b> .....	<b>\$11,227.01</b>
 <b>TOTAL</b> .....	 <b>\$160,547.22</b>



3. Brodin Studios  
Kimball, MN  
Total Cost: \$125,000

### **Artist Statement**

At Brodin Studios, we believe public sculpture has the power to carry legacy, embody values, and forge a lasting emotional connection between a community and its heroes. For over 40 years, our studio has been devoted to telling the stories of real people through lifelike bronze sculptures—those who serve, protect, and uplift others in times of need.

Our work is rooted in respect for service and sacrifice. Every piece we create is guided by a deep sense of responsibility: to honor the truth of a uniform, the authenticity of gesture, and the soul of a story. We are drawn to commissions like Denton's because they share our commitment to preserving history through meaningful visual narratives.

Through enduring bronze, we strive to create not just a sculpture, but a landmark—one that honors Denton's firefighters while connecting with all who pass by. At Brodin Studios, we strive for more than art; it's a legacy, made visible.

### **Proposed Sculpture**

Life-Size Firefighter w/ Kid and Axe running through lit bronze char textured doorframe



## Budget

- Statue (life-size)
  - \$65,000
- Doorframe
  - \$25,000
- Base
  - \$20,000
- Delivery/Installation
  - \$10,000
- Electrical/Misc
  - \$5,000
- **Total: \$125,000**

4. Cesar Henao  
Vaison-la-Romaine, France  
Total Cost: \$195,000

## "TIME SPIRE" FIRE STATION #6 DENTON TX MONUMENTAL PARAMETRIC SCULPTURE PROJECT PROPOSAL BY CÉSAR HENAO

### Declarative Preamble

I am honored to present my proposal for the creation of *Time Spire*, an outdoor 3D artwork conceived as a monument to vigilance, permanence, and elevation, standing as a defining landmark at Fire Station #6 in Denton, Texas. Through its ascending parametric form, *Time Spire* embodies the continuous presence of first responders, highlighting their dedication to safeguarding the community.

Following the conceptual exploration initiated with *Luminous Watch*, *Time Spire* emerges as a unique vision, responding to the distinct mission and expectations of Fire Station #6. While *Luminous Watch* was designed as a beacon of readiness, *Time Spire* focuses on the passage of time, the rhythm of service, and the unwavering continuity of protection, reinforcing the cyclical nature of vigilance.

I deeply appreciate the opportunity to participate in this Bid Procurement Process, and I am fully committed to delivering an artwork that aligns with the civic identity of Denton. My expertise in large-scale public installations, combined with precise engineering and material innovation, ensures a seamless execution of this commission.

### Project Overview

With its 365 stainless steel tubes, *Time Spire* is a visual chronicle of vigilance, symbolizing the daily dedication of first responders throughout the year. Its ascending cylindrical structure, crowned by a 55° inclined cut, interacts with sunlight to generate shifting shadows, reinforcing its role as a time marker within the station's architectural presence.

### Production and Shipping

The sculpture will be fabricated at a specialized studio in Poland, where I have successfully completed similar large-scale commissions. The studio is equipped with state-of-the-art facilities and a highly skilled production team, ensuring precision execution. Throughout the Bid Procurement Process, I have carefully examined transportation constraints, structural dimensions, and budgetary requirements to optimize the design and logistics of *Time Spire*. The shipping phase will span approximately two months, allowing ample time for customs clearance and site preparation before installation.

### Commitment to Excellence

I am dedicated to delivering an artwork that not only meets but exceeds expectations. My experience in monumental sculptural works allows me to address technical, aesthetic, and material standards while ensuring long-term sustainability for the installation. With a well-defined execution timeline, I am fully committed to achieving the October 2026 completion date, ensuring that *Time Spire* becomes an integral landmark in Denton's visual and civic landscape. I am confident that *Time Spire* will stand as a symbol of endurance, protection, and pride, offering an impactful tribute to the firefighters of Denton while enriching the city's cultural identity.

Thank you for considering my proposal as part of this Bid Procurement Process. I look forward to collaborating with the City of Denton to bring this vision to life.

# "TIME SPIRE" FIRE STATION #6 DENTON TX

## MONUMENTAL PARAMETRIC SCULPTURE PROJECT PROPOSAL BY CÉSAR HENAO

### Introduction

#### "TIME SPIRE" – A Monument to Vigilance at Fire Station #6, Denton

Fire Station #6 in Denton, Texas, stands as a pillar of permanence, embodying the unwavering vigilance of first responders. Day after day, firefighters dedicate themselves to continuous protection, ensuring the safety and well-being of the community. Time Spire was conceived to materialize this constancy of service, integrating time, elevation, and resilience into a singular sculptural form.

More than a visual landmark, this monumental 3D artwork embodies the watchful presence and enduring commitment of firefighters. Its ascending parametric composition, forged from 365 stainless steel tubes, reflects the cycle of time, symbolizing the passage of days and the perpetual rhythm of duty. Through its light interaction and evolving shadows, the sculpture reinforces the idea that vigilance is not static—it is ever-present, adapting, and defining the essence of service.

Where Luminous Watch stood as a beacon of readiness, Time Spire establishes continuity, celebrating perseverance and the relentless march of time. This proposal details its vision, technical realization, and integration into Denton's civic landscape.

A pillar of time, sculpted in steel, forged in vigilance, and standing in unbroken continuity.



## DESCRIPTION OF THE ARTWORK

**Title:** TIME SPIRE

**Artist:** César Henao

**Medium:** Stainless Steel L316

**Dimensions:** 19.7 feet Height (6 meters)

**Base Width:** 7.9 feet (2.40 meters)

**Structure:** 365 parametric stainless steel L316 tubes of 2 inches (5 cm) diameter each

### Artistic & Conceptual Overview

*TIME SPIRE* is a monumental parametric sculpture conceived as a pillar of vigilance, permanence, and elevation, marking the presence of Fire Station #6 in Denton, Texas. Through its ascending cylindrical formation, the work symbolizes the continuity of service, embodying the rhythm of time and the daily dedication of first responders.

Each of the 365 extruded steel tubes represents a day in the cycle of vigilance, forming a structural calendar in motion. The upper portion of the sculpture, inclined at 55°, interacts dynamically with light, casting an evolving circular shadow—a temporal marker akin to a sundial, reinforcing the passage of time.

### Material & Structural Features

**Parametric Composition:** The arrangement of tubes follows a precisely calculated distribution, generating fluidity and density within the form.

**Polished Stainless Steel Finish:** The truncated upper edge ensures that the sculpture projects a distinct circular shadow, evolving with the sun's movement.

**Shadow Projection:** A mirror-finished stainless steel band 19.7 inches (wide), x 1.6 inches (thick) encircles the base, capturing light reflections, emphasizing motion, resilience, and transformation.

**Durability & Site Integration:** Fabricated in weather-resistant L316 stainless steel, the structure is designed for long-term stability with minimal maintenance.

### Symbolism & Community Interaction

**A Pillar of Time:** *TIME SPIRE* materializes 365 days of service, embodying the endurance of firefighters in their unbroken commitment.

**A Landmark of Vigilance:** Standing at Fire Station #6, the sculpture is a visual anchor, reinforcing the sense of protection and permanence.

**Light & Time Dialogue:** The interplay of shadows and reflections transforms the artwork into an active, evolving presence within its environment.

By embodying the rhythm of time and the endurance of service, *TIME SPIRE* creates a landmark that reflects permanence and vigilance in the heart of Denton. The interplay of its parametric structure and evolving shadows establishes a visual chronicle of resilience, reinforcing the firefighters' continuous presence. As Luminous Watch the project for Fire Station #5, captured the moment of activation, *TIME SPIRE* expands the narrative, expressing constancy, elevation, and the cyclical nature of protection.





5. Christine Sanders  
Denton, TX  
Total Cost: \$117,000

## "Eternal 6"

This proposal is for the artwork to accompany the new Fire Station 6 "The Bull Pen" on Teasley Ln. in Denton Texas. *Eternal 6* is a sculpture and mural installation designed to honor the values and sacrifices represented by the Bull Pen Station and the community it serves. The central feature is a striking "eternal flame" shaped as a 6- a symbol of both continuous remembrance and the identity of the station, the sculpture anchors the space both physically and symbolically. The mural behind the sculpture is a visual backdrop reflecting the, movement, warmth, and strength tying into the theme of the eternal service. On the ground, in the concrete are the words, Honor, Bravery, Courage, and Dedication together with the zeroscaping provide harmony to the entire space and amplify the message and values of those who serve and protect at "The Bull Pen" Station 6

**Artist: Christine Sanders**

**Location: Denton Fire Station 6, Denton Texas**

**Sculpture Title: *Eternal 6***



[artistxine@yahoo.com](mailto:artistxine@yahoo.com)

## Christine Sanders Artist Statement Proposal for Denton Fire Station 6 Public Art Installation

Denton Fire Station 6, affectionately known as "The Bull Pen," sits just across from my neighborhood and has been a meaningful part of my daily life for the past 24 years. More than just a firehouse, it's a place of pride and belonging—a home away from home for the brave men and women who serve our city. With this project, my aim is to create a meaningful tribute to those who have served and continue to serve at Station 6, capturing their spirit and honoring their legacy.

The Eternal Flame is a powerful symbol in the firefighting community—representing honor, remembrance, and unwavering service. My proposed sculpture, titled *Eternal 6*, transforms the number 6 into an eternal flame crafted from Core 10 steel. A small, continuously lit bulb will glow at its center, and at night, carefully placed spotlights will animate the sculpture, creating a gentle, dancing light.

Behind the sculpture, a bold mural will act as a visual landmark for Station 6. It will feature two key images: the firefighter's American flag and a bull, accompanied by the "Bull Pen" banner. Rendered in black, white, and red, the mural's aesthetic will be clean and striking—providing a powerful backdrop to the *Eternal 6* sculpture.

My work is always community-focused, and this piece is no exception. I consulted with Station 6 firefighters, incorporating elements they personally take pride in. Their voices helped shape the vision. The surrounding space is also part of the art—inscribed in the sidewalk will be the words Honor, Bravery, Dedication, and Courage, encircling the sculpture and mural.

The site will be landscaped using a zeroscape of crushed white granite, rust-colored boulders to echo the sculpture's patina, and a few native evergreen sages to provide color and life. Hidden spotlights will be tucked into the boulders to maintain a natural look. A custom bench, with legs shaped like the number 6, will sit nearby as an inviting spot for reflection.

This installation is more than a piece of art—it's a heartfelt tribute. It celebrates the strength, pride, and commitment of Denton's Fire Station 6 and creates a lasting symbol of appreciation from the community it so faithfully protects.

[artistxine@yahoo.com](mailto:artistxine@yahoo.com)



## Eternal 6 and The Bull Pen



- The "6" flame is 3' wide 4' tall on a 2' diameter cylinder.
- The metal base is a 4' diameter cylinder with a beveled top that is 4' high at the highest point and 3' high at the short end of the slope. The slope has the fire fighter shield on it. The base is hollow and powder coated.
- This all sits on a concrete base that is 6' deep and 16' square. The words, Honor, Bravery, Courage, and Dedication will be on plaques embedded in the concrete.



- The *Eternal 6* Flame can have layered steel pieces giving it more of a flame look and will be powder coated in red.
- There will be electric running through the center of the sculpture for a light that will be flame looking and will stay on 24/7 to give the eternal flame glow in the center of the 6.
- Additional spotlights will be placed, hidden in the boulders of the landscape to shine on the mural and the sculpture at night. The spot lights on the *Eternal 6* can be special SFX light that have movement of red light that will give the flame a flicker at night.
- Final shape of sidewalks and landscape boarder will be determined with the collaboration of the Architects and landscapers of the station build to ensure a cohesive look.

artistxine@yahoo.com

## Eternal 6 and The Bull Pen



- The *Bull Pen* mural is approximately 16' high by 22' wide. The final size will be determined when the wall is complete and the full uninterrupted space can be seen.
- The banner for Fire Station 6, will be the width of the windows on the side of the building or approximately 9' wide by 7' high.
- The sculpture will be positioned so that it will be seen between the bull and the banner from the entrance of the fire station or the corner of Teasley and Hunter's creek rd.
- There will be a bench that goes in harmony with the aesthetic of the sculpture and mural allowing for sitting for a moment of reflection.

- Landscaping will be a zeroscape, with crushed white granite larger gray stones and large rust colored boulders. Boulders will hide spotlights and reflect the color of the patina on the sculpture.
- A few sage bushes and native plants for a pop of color and life.
- The color scheme is monochromatic, gray, black, and white with red. Accents of rust color in the metal patina and the boulders will give this area a striking yet simple and clean look. The bold image of the bull and the fire fighter's flag show the strength of the station and those who serve there, and the *Eternal 6* keeps the reverence and sincerity of the space those who pass by or visit.

artistxine@yahoo.com

# Project Plans

## Budget

• Mural: Cost of labor, materials, and rental equipment.	\$20,000.00
• Sculpture: Cost of core 10 Steel, powder coating, patina, welding and installation labor.	\$30,000.00
• Concrete: Cost of sidewalks and structural base.	\$5,000.00
• Landscape: Materials and labor.	\$20,000.00
• Park Bench:	\$4,000.00
• Architectural and Engineering fees.	\$5,000.00
• Electrical and lighting	\$8,000.00
• electrical Engineer	\$3,000.00
• Artist 3D rendering ( Chris Goodwyn)	\$2,000.00
• Artist fee for project	\$20,000.00

## Time Line

This project scheduled to be completed in 2026 when the construction of the Fire Station 6 on Teasley Ln. is completed, and the landscaping is beginning, before the open of the station. All work for the *Eternal 6*, and the Bull Pen mural with landscaping will be completed prior to the grand opening of the station.

## Maintenance

There is no maintenance need for the mural. The zeroscape landscaping will only need an occasional check for weeds or trash pick up that may blow in. The *Eternal 6* has lighting and may need a change of bulbs every couple of years, or replacement bulbs incase of hail damage.

## cost

\$117,000. is the total cost of the sculpture, "Eternal 6" ad The "Bull Pen" mural. This includes the cost of supplies labor and Engineer fees.

6. Christopher Fennell  
Birmingham, AL  
Total Cost: \$150,000

### **Artist Statement**

Artist-Engineer Christopher Fennell has built sculpture in 27 states, his sculpture appearing in movies, River Thief and Damnation, and in magazines such as AIT, Sculpture and Make. The Green Sculptor is known for his vortexes of everyday objects made into colossal sculpture inspired by nature. He uses local history and recycled materials to create site-specific art. The artist takes advantage of egress to deliver a time based experience of discovery. At a distance the viewer sees an identifiable object: a 24 foot tall wave, a 26 foot tall bean sprout, a 24 foot tall fireball, then on closer inspection the viewer discovers the material of the sculptures: Canoes, little red wagons or fire ladders. The viewer is then visually encouraged to walk through the sculpture or sit down on one of its benches; in doing so the viewer becomes part of the sculpture.

### **Proposed Sculpture**

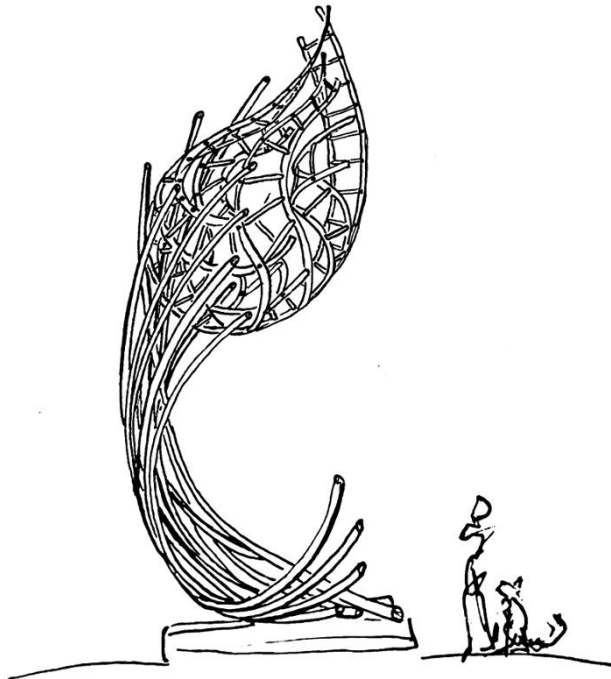

For the Fire Station Number Six, Christopher Fennell proposes sculpting “Water Fire Ball” a fireball of decommissioned fire ladders held aloft by a wave of pipe. In the same way that the artist sculpted a fireball of decommissioned fire ladders for Allen’s Number Five fire station with a base of train rails, he would like to do a sculpture once again using decommissioned fire ladders from Denton, but held aloft by a wave of pipe. Christopher has built many waves of pipe including the *Industrial Pipe Wave* that won Phoenix Time Best Installation of 2022. Residing in Denton you might know Fennell’s latest installation *Barnyard Promenade* along 3 mi of North Beach Street where he installed twelve working weather vanes where the animals are made out of locally recycled material. To illuminate the Denton installation he will include red and orange LED floodlights that will light up the fireball at night- so that as you drive by the sculpture the different facets of the ladders will reflect the two colors of light differently, causing the fire ball to appear to flicker red and orange.

Fennell will build a series of models to develop the concept before construction.

For a \$1000 fee Christopher will build a scale model of the proposed sculpture to better convey what the sculpture will look like.

### **Budget**

Donated Decommissioned Fire Ladders	\$0
Shipping Ladders to Studio	\$1900
Wiring and Lighting	\$2,800
Structural Engineering Drawings	\$6,000
Pipe bending	\$8,000
5” steel pipe for water droplet	\$6,800
1” Base plates	\$3,100
1/2" Steel Plate for tabs	\$670
Insurance	\$3,515
Consumables	\$2,600
Labor to build sculpture	\$64,485
Sand Blasting	\$4,000
Lumber for scaffolding	\$1,230
Fasteners	\$1,700
Epoxy Paint and Urethane	\$2,300
Welding Supplies	\$1,700
Rental bucket truck for installation	\$1,600
Rental telehandler for installation	\$2,100
Transportation of sculpture to site	\$7,000
Artist Fee	\$6,800
Travel Expenses	\$3,000
Building Permit	\$700
Labor to Install Sculpture	\$18,000
<b>Total</b>	<b>\$150,000</b>



7. Sujin Lim / Cloud Study LLC  
Brooklyn, NY  
Total Cost: \$200,000

Sujin Lim

***Dwell in Clouds***



**Materials**

Stainless Steel and Urethane Painted Aluminum

**Approximate Dimensions**

Approx. 5' x 5' x 20'

*Dwell in Clouds* is a 20 foot tall sculptural installation shaped like both a house and a cloud. It serves as a powerful metaphor for home, journey, and limitless aspirations, evoking the emotional landscape of those who dedicate their lives to public service. Inspired by the strength and quiet heroism of firefighters, the sculpture symbolizes both protection and elevation: the grounded security of a house and the ethereal hopefulness of a cloud.

Positioned prominently along Teasley Lane at the eastern edge of the Fire Station #6 site, the sculpture will function as a visual and symbolic beacon, welcoming passersby and station personnel alike. Fabricated in durable materials such as stainless steel or urethane painted aluminum, *Dwell in Clouds* will offer striking visibility during the day and a gentle luminescence at night through a subtle internal lighting system. The lighting may be programmed to softly glow in response to emergency call activation, acknowledging the fire station's active service in real time. In moments of silence, it will remain a contemplative object; in moments of emergency, a quiet signal of action and care.

The cloud form becomes a skyward symbol of shared care, mirroring the calm presence of first responders and the suspended stillness before a call to action. The house shape references the fire station itself as a second home, a place where courage is nurtured and selflessness becomes daily practice. Together, these forms reflect the dual roles firefighters hold in our communities as steadfast, grounded protectors and as aspirational figures who rise to every moment of need.

The materials used, brushed stainless steel or urethane painted aluminum, offer both strength and reflectivity. The mirrored surface will subtly reflect the sky, the landscape, and the people around it, reminding viewers of their connection to those who serve. Just as firefighters reflect the needs of their communities, the sculpture reflects back the environment and people it stands among.

The installation will be situated within a landscaped zone near the station, offering a space for community gathering and quiet appreciation. This site specific positioning reinforces the sculpture's role not only as a landmark but as a point of contemplation and connection.

As one of the first public artworks commissioned through Denton's 2023 Bond Program, *Dwell in Clouds* aspires to set a new standard for community public art, balancing aesthetic impact with deep thematic resonance. It invites every viewer to reflect on memory, aspiration, and the invisible acts of heroism that shape our daily lives.

### **Technical Specifications**

- **Durability:** Engineered to withstand outdoor conditions, including wind, rain, and UV exposure. Corrosion-resistant coatings will be applied to extend longevity.
- **Lighting System:** Motion-activated or solar-powered LEDs embedded within the cloud structure to enhance visibility while maintaining energy efficiency.

### **Maintenance**

*Dwell in Clouds* is designed with longevity and durability in mind, using materials that are well suited for permanent outdoor display. The sculpture's primary structure will be constructed from either brushed stainless steel or urethane painted aluminum, both of which are resistant to corrosion, fading, and environmental damage. These materials require minimal upkeep and are commonly used in public art settings for their low maintenance needs and long term performance.

Routine maintenance will primarily consist of visual inspections and basic surface cleaning. It is recommended that city staff conduct a visual check at least once a year, especially after significant weather events, to identify any debris buildup, bird droppings, or surface wear. Once a year, preferably in spring and fall, the sculpture should be cleaned with a mild detergent diluted in water, using a soft cloth or sponge to avoid scratching the surface. All fasteners, seams, and welded joints should be reviewed at the same time, along with a functional test of the internal lighting system if installed. Lighting elements will be housed in waterproof, UV resistant enclosures and are expected to last over 50000 hours before requiring replacement.





8. Daniel Borup  
Shelley, Idaho  
Total Cost: \$200,000

To the Selection Committee

Thank you for this opportunity to submit a proposal for Fire Station #5 and #6. I am excited because I feel my work and expertise can greatly benefit this location and community. I am submitting the same design for both fire stations and would be honored to create this sculpture for either of them. I am a traditional representational sculptor. Bronze will be a great material for this project as it is strong and durable and lasts well in any kind of weather. It is also a classic material for public art and holds up extremely well to viewer interaction

My design depicts two fire fighters in action, creating a dynamic and emotional piece. One spraying the fire hose and the other next on the hose line helps to stabilize. These fire fighters are fully dressed in their turnout gear including the masks. Because of this, they will not be viewed as fire fighters representing any specific gender or ethnicity but rather as courageous fire fighters that the viewer can freely interpret as they wish. These firefighters are moving up stairs which helps to strengthen the sense of action and movement. Visually the hose also guides the viewer through the piece as it wraps around the stairs and directs the viewer to the plaque of the Maltese Cross.

In my proposal this Maltese cross is just a generic one that can be found at many fire departments. I would be happy to make this plaque more specific to Denton with some unique wording and imagery. This plaque is a great opportunity for the committee to help make this piece a memorial specific to Denton. These changes can be decided with help from the committee. This plaque will be two feet tall and wide, making it large enough to be seen from the road from passing cars. This sculpture will be cast in bronze and securely fastened to the concrete pedestal. Lighting will be installed to light it up at night.

The large pedestal, the two figures, the fire hose and the plaque give the piece a monumental impression. All of these elements combined can be quite costly. In order to stay in budget I will be reusing the molds from a piece I have already created for Fire Station #6 in Meridian Idaho. This piece is an edition piece and I have the rights to use this piece again for this memorial in Denton. By reusing these molds I am able to save a little time and money to stay within budget, It also gives you the benefit of being able to see exactly what part of the sculpture will look like when it is installed. I will be changing the helmet patch to be specific to the Denton Fire Department, but all else about this sculpture will remain the same. The second figure will be sculpted to match this first piece stylistically so the entire piece harmonizes.

I have experience with several Public Works as evidenced in my resume. I have also been a finalist for various public art sculptures and have created in-depth proposals with renderings, scale models, and itemized budgets. Working with stakeholders, I have created public art for Libraries, Parks, Roundabouts, Schools, City Halls, Fire Stations, and Police Stations. Each piece has been created on time and within budget.

Aiming to convey the goals of each selection committee, I am willing to hear what preferences they have and adapt my design as necessary. I am eager to use my experience and expertise to create a proposal and ultimately see my sculpture become a reality. Thank you for taking the time to consider my application. I look forward to hearing from you.

Sincerely,



Daniel Borup  
Professional Artist  
daniel@danielborup.com





Denton Fire Fighter Memorial Model



Denton Fire Fighter Memorial Model With Measurements

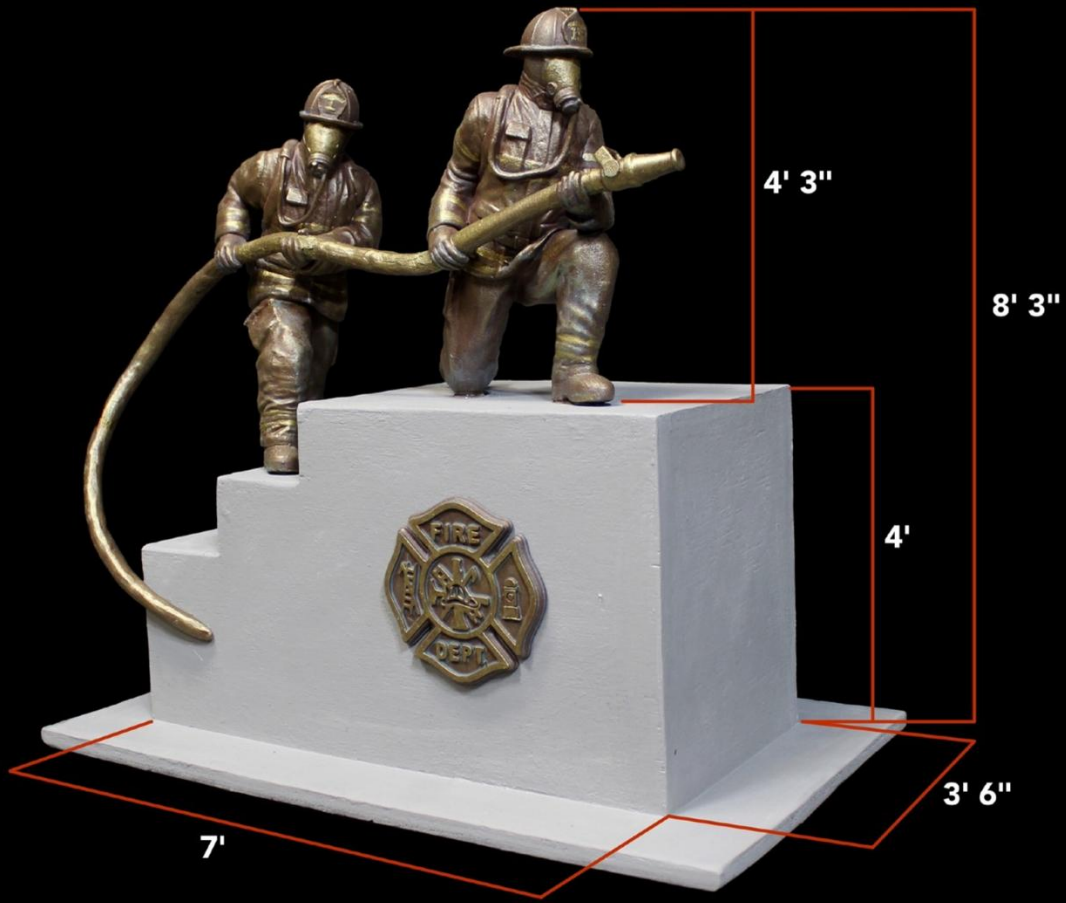

Each of my projects have been completed on time and within budget.

**Timeline**

**June, 2025**

- Agreement signed.
- Amateur fabrication begins.

**June 2025 - January 2026**

- Sculpting
- I will be in touch periodically about the sculpting progress.

**January, 2026**

- Clay sculpting finished.
- Photos sent in for approval.

**February, 2026**

- Deliver Sculpture to Foundry.

**July, 2026**

- Receive sculpture from Foundry.

**July, 2026**

- Sculpture Installation.

**Budget**

Artist Design Fee	\$30,000.00
Labor	\$70,000.00
Foundry/Bronzing	\$61,000.00
Clay	\$500.00
Amateur Fabrication	\$500.00
Misc Supplies	\$1,000.00
Travel & Shipping	\$4,000.00
Contingency	\$15,000.00
Insurance	\$1,000.00
Engineer Fee	\$1,000.00
Installation	\$1,000.00
Pedestal and Lighting	\$15,000.00
Total:	\$200000.00



9. Vito Di Bari/Di Bari & Associates  
Miami, FL  
Total Cost: \$135,000

Dear Selection Committee,

I am honored to submit my proposal for the sculptural art installation at Fire Station 6. *Guardian of Hope* reflects and honors the City of Denton's call for installations that celebrate heroism, selflessness, and the rich history of firefighting in Texas and the United States, while incorporating an active lighting component responsive to emergency calls.

*Guardian of Hope* is a vibrant, large-scale sculptural panels combination anchored on a simple concrete base. The artwork captures a profoundly emotional scene: a firefighter, wearing a helmet marked with the number 6 — a direct tribute to Fire Station 6 — cradles a small child in his arms. This depiction powerfully symbolizes rescue, protection, and the deep compassion inherent in the firefighter's mission.

The figures are framed against a large circular backdrop, laser-cut to depict dynamic, stylized flames in tones of orange and yellow, representing both the danger firefighters face and the courage required to confront it. The sculpture is designed in layered, relief style, giving it a strong three-dimensional presence. Its vivid color palette — bold reds, blues, oranges, and yellows — evokes the energy of firefighting, the spirit of Texas, and American patriotism.

Material and Construction:

- The sculpture is made of laser cut mild steel layers.
- The layered design creates visual dynamism, producing striking shadow and light effects both during the day and at night.
- The sculpture is anchored to a simple, clean concrete base for structural integrity and aesthetic simplicity.

Color and Lighting Concept:

- During daytime, the firefighter and child are rendered in bright blue, white and red tones - a color palette that represents Texas and the USA.
- At night under normal conditions, the sculpture is softly illuminated: the firefighter and child glow in calm blue hues, while the flame background emits a warm, gentle light, symbolizing the balance between safety and danger.
- During emergency calls, the sculpture's internal lighting responds dynamically: the flames intensify to vivid yellow and red tones, creating a dramatic and urgent visual signal that honors the firefighters' swift action in real time.

Lighting System:

- Discreet spotlights are integrated at the base of the sculpture to provide even, dramatic illumination at night.

- The lighting control system is synchronized with the station's emergency call system, ensuring real-time visual response to emergency activations.
- The light fixtures will simulate the movement of the flames, adding dynamism and drama to the scene. Here an example, in our case the color will always be orange - <https://www.youtube.com/shorts/dzYy-9Wgb1k>

Artistic and Community Alignment:

*Guardian of Hope* not only captures the selfless spirit of first responders but also serves as a living tribute to the history and future of firefighting in Texas and the United States. Through its emotive imagery, dynamic color interplay, and interactive lighting, the piece will stand as a lasting symbol of bravery, compassion, and community resilience at Fire Station 6.

Maintenance:

The sculpture will be made of mild steel, painted with industrial direct-to-metal enamel paint, protecting it from any kind of weather conditions. It will require minimal maintenance, that can be performed by non-artists (public work employees), see more details in the maintenance and conservation plan attached to this application.

It would be an honor to create a piece that stands as a beacon of inspiration for the City of Denton, its citizens, and its brave first responders at Fire Station 6.

Thank you for your thoughtful consideration.

Sincerely,

Vito Di Bari





DAY



NIGHT  
*Normal conditions*

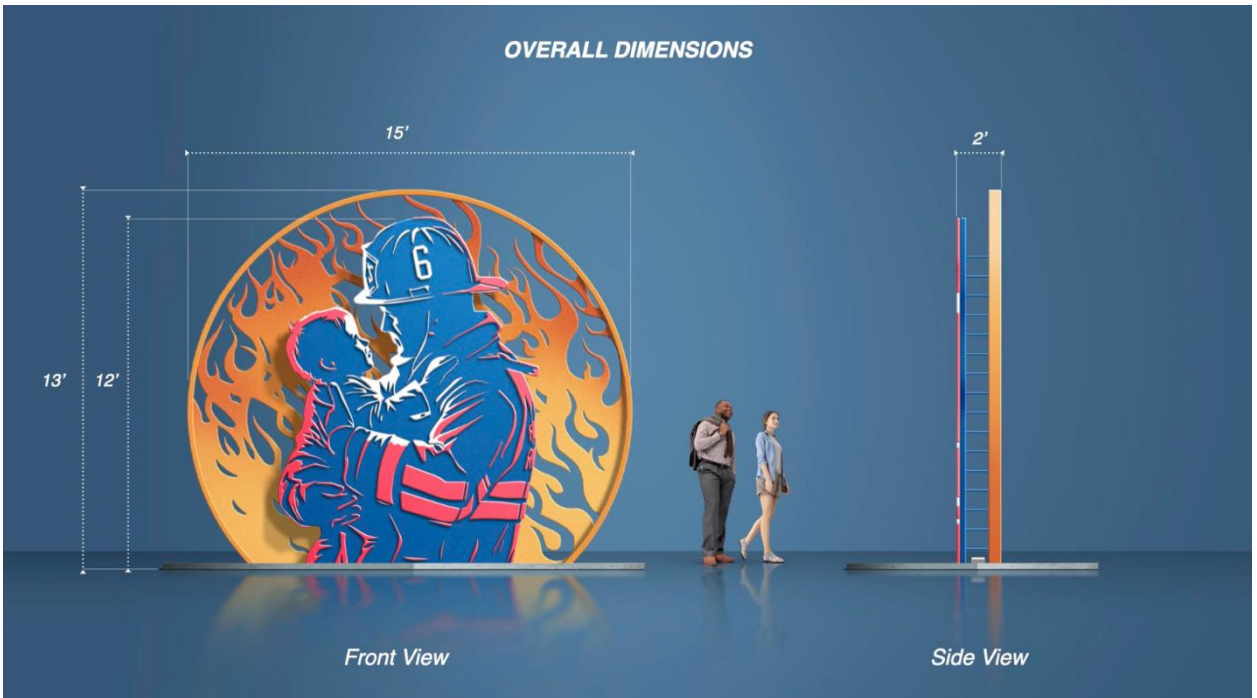



## ROM (Rough of order of magnitude pricing)

The project budgets listed in the following pages are informal cost estimates provided for early phase planning and budgeting purposes only.

ROM pricing must be finalized after proper engineering, costing and planning have been executed.

ITEM DESCRIPTION	COST
Artist Design and Project Management Fee (10%)	13,500.00 USD
Fabrication (45%)	60,750.00 USD
Installation (20%)*	27,000.00 USD
Professional Consultant Fees (10%)	13,500.00 USD
Insurance, Permits, Legal, Accounting, T&A, Quota of Overheads (10%)	13,500.00 USD
Contingency (5%)	6,750.00 USD
	<b>TOTAL</b>
	<b>135,000.00 USD</b>

*\*Access to electricity for night time illumination shall be provided by the city*

## Maintenance and conservation plan

Task	Frequency	Materials	Expertise Level	Protocol
<b>Remove debris</b>	As needed during landscaping	Leaf blower	Technician or Groundskeeper	Use a leaf blower to remove all debris from the sculpture and base during routine landscaping (ex: plants, insects, garbage, etc.)
<b>Wash</b>	Twice yearly	Boom/scissor lift Hoses (not power washers) Buckets Orvus Non-Ionic Surfactant Sponges & soft-bristled brushes	Technician or Groundskeeper	<ol style="list-style-type: none"> <li>1. Rinse the sculpture &amp; concrete pad with water using standard-pressure hoses (not a power washer)</li> <li>2. Scrub the sculpture &amp; concrete pad with an Orvus and water solution mixed in a bucket at a 1 tbs : 1 gallon ratio</li> <li>3. Rinse the sculpture &amp; concrete pad with water using standard-pressure hoses (not a power washer) thoroughly to remove all suds and grime</li> <li>4. Repeat as necessary to remove all grime, debris, etc.</li> </ol> <p><i>Avoid using any abrasive cleaning agents or materials on the painted surface (such as steel wool or Scotchbrite)</i></p>
<b>Condition Inspection</b>	Once yearly	Boom/scissor lift	Technician or Groundskeeper	<ol style="list-style-type: none"> <li>1. Inspect the sculpture overall for any structural or surface damage</li> <li>2. Inspect for any scratches, dings, or other losses to the coating and/or paint layers</li> </ol>
<b>Spot apply paint &amp; coating losses</b>	Once Yearly	400-800 grit wet sandpaper paint (listed above)	Conservator/ experienced paint applicator	<ol style="list-style-type: none"> <li>1. If losses to the coating and/or paint layers are observed, spot apply paint and/or coating to ensure the metal is protected. Prep the area by wet sanding with a 400-800 grit wet sandpaper before re-application</li> </ol>
<b>Corrosion mitigation</b>	As needed	n/a (consult conservator)	Conservator	<i>If any corrosion products (such as rust) are observed, immediately consult a conservator for corrosion mitigation and spot re-application of paint and coating.</i>
<b>Full re-paint &amp; re-coat</b>	As needed (~15 – 20 years after install)	400-800 grit wet sandpaper paint (listed above)	Conservator/ experienced paint applicator	<i>Eventually the coating and paint layers will fail, leading to flaking, fading, and loss. When this is observed, perform a full re-paint and re-coat.</i>

10. Sheryl Forward / Endavant LLC / Big Statues  
Tyler, TX  
Total Cost: \$186,200

# STATUE DESIGN

Initial Statue Design and Concept Art



Our design is bold, inspiring, and created to immediately capture attention. With fire elements, the sculpture honors the bravery and sacrifice of all firefighters. We are happy to provide a second design, but please note that concepts normally take weeks to develop, and additional time will be needed to ensure the same level of detail and impact. We will happily modify the final concept to best reflect your vision.

YOUR PROJECT

# BUDGET

Description	Quantity	Price
8' Bronze Firefighter with a Child Statue	1	\$155,900
Large Fire Base	1	\$18,900
Lighting		\$3,500
Installation Estimate		\$7,900
<b>Total Price</b>		<b>\$186,200</b>

Total Statue Cost includes:

- Artist Fee
- Materials Used
- Clay Work
- Artwork/Sketches
- Fabrication
- Mold and Foundry Fee

**BIRD'S EYE VIEW:**

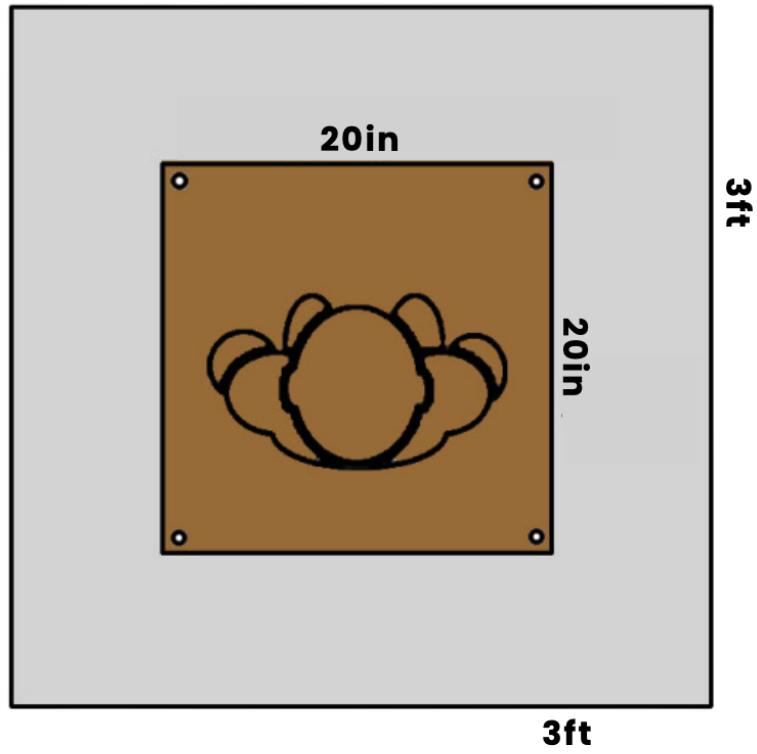

**SIDE VIEW:**

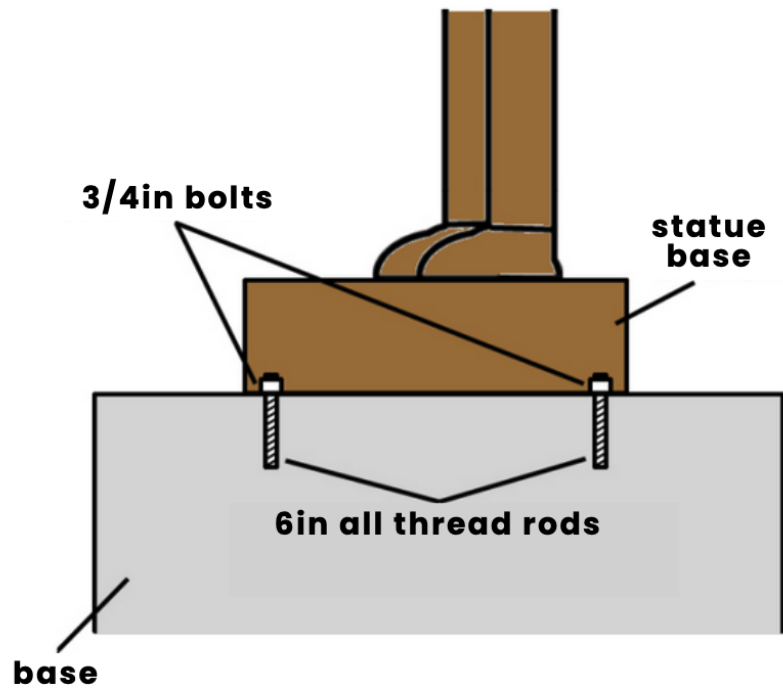



11. Donna Stevens / Go Wild Fabrication and Welding, LLC  
Fort Worth, TX  
Total Cost: \$157,000 - \$197,000

## **FIRE STATION #6**

Deana Stevens  
Go Wild Fabrication and Welding, LLC  
6442 Nine Mile Bridge Rd.  
Fort Worth, TX 76135  
April 8, 2025

Parks and Recreation Department  
901 Texas St.  
Denton, Texas 76209

Parks and Recreation Department,

As a diverse artistic team and co-owners of Go Wild Fabrication and Welding, LLC, we are excited to submit our proposal for the Fire Station #6 public art opportunity. With a background that blends large-scale sculpture, graphic design, and structural steel fabrication, we create work that honors community, resilience, and craftsmanship—values that align deeply with the spirit of fire service.

We were so excited about this opportunity that we are submitting three different design ideas for consideration. Each concept reflects our creative vision and commitment to celebrating the bravery of first responders and the strength of the community they serve. We wanted to provide a range of options to inspire the space and ensure a meaningful connection to the Fire Station #6 location.

Why choose us? Because we don't just design—we fabricate and install the artwork ourselves. Go Wild Fabrication and Welding, LLC is a fully equipped shop with all the machinery and tools necessary to build the sculpture in-house. We even have a structural engineer on staff, which allows us to handle engineering needs quickly and make adjustments on the fly. By keeping the entire process under one roof, we eliminate the delays and complications that often come from outsourcing to multiple vendors—saving time, cost, and stress.

Thank you for considering our proposal. We have included all required materials, including visuals of past work and a detailed project concept. We would be honored to contribute to this meaningful space and welcome the opportunity to further discuss our ideas with your team.

Sincerely,  
Deana Stevens  
Go Wild Fabrication and Welding, LLC  
(619) 244-7576  
deana@gowildfabrication.com  
www.gowildfabrication.com

SPECIFICATIONS:

MATERIALS:

WELDED METALS- MILD STEEL, STAINLESS STEEL,  
CORTEN RUSTED STEEL

PAINT FINISHES:

NO PAINT NEEDED. THE CORTEN WILL RUST NATURALLY  
AND IS LONG LASTING.

SCULPTURE WILL BE CONSTRUCTED OF A STEEL  
FRAME WITH WELDED/FORMED CORTEN STEEL ON THE SURFACE.

PROPOSED SCHEDULE:

4 MONTHS AFTER FINAL  
DESIGN AND ENGINEERING/APPROVALS

MAINTENANCE:

CORTEN STEEL DOES NOT REQUIRE  
MAINTENANCE AS IS MEANT TO RUST  
NATURALLY.  
THERE IS NO PROPOSED MAINTENANCE  
SCHEDULE FOR THIS SCULPTURE.

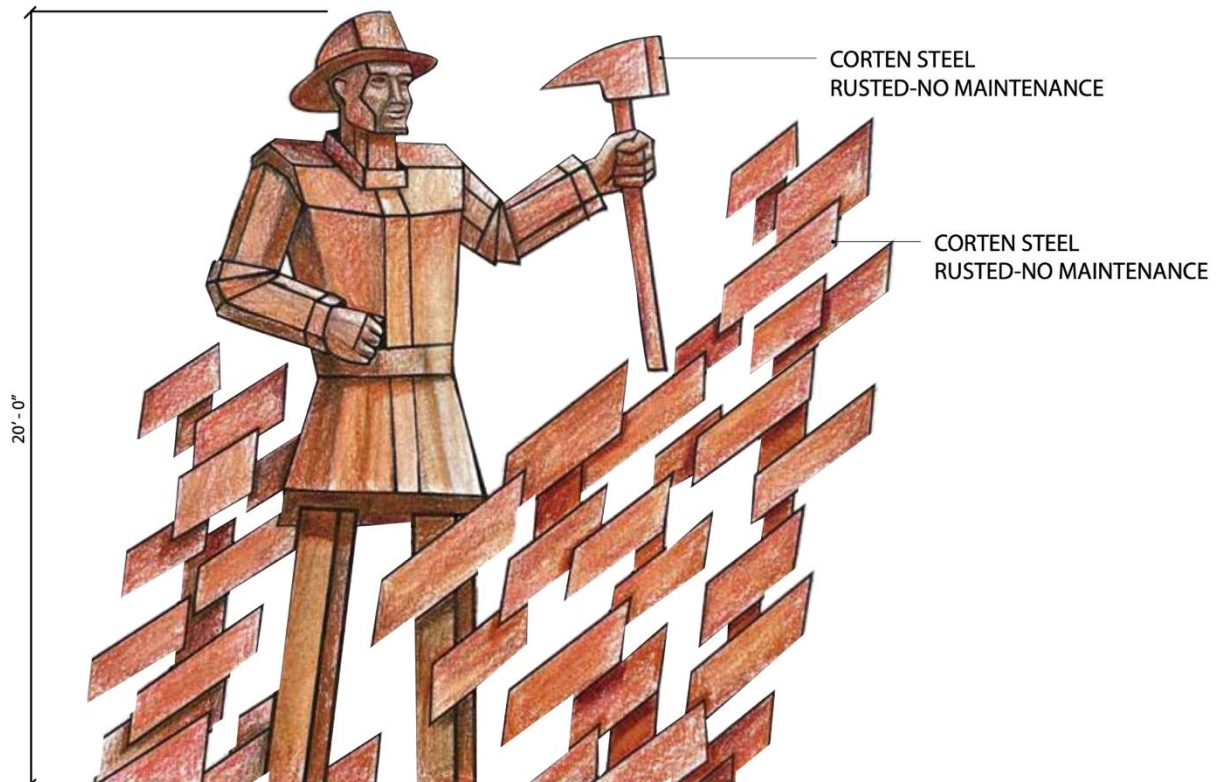

COST BREAKDOWN: \$197,000

ENGINEERING: \$10,000

UNDERGROUND POWER AND LIGHTING: \$12,000

PAVING & CONCRETE FOOTINGS: \$20,000

METAL: \$45,000

EQUIPMENT RENTALS: \$5,000

LABOR/CONSTRUCTION: \$105,000

**NOTE: LIGHTING WILL ALLOW FOR COLORED LIGHTS TO  
DISPLAY WHEN EMERGENCY CREWS ARE DEPLOYED. THE  
LIGHTS WILL REFLECT OFF THE METAL SURFACES, CREATING  
A DYNAMIC INTERPLAY OF HIGHLIGHTS AND SHADOWS THAT  
ENHANCES THE SCULPTURE'S DEPTH AND MOVEMENT AS PEOPLE  
DRIVE/WALK PAST. IMAGINE HOW BEAUTIFUL THE CASTED SHADOWS  
WILL BE!**

FIRE STATION - 6  
ART LOCATION PLAN



ELEVATION VIEW - NTS

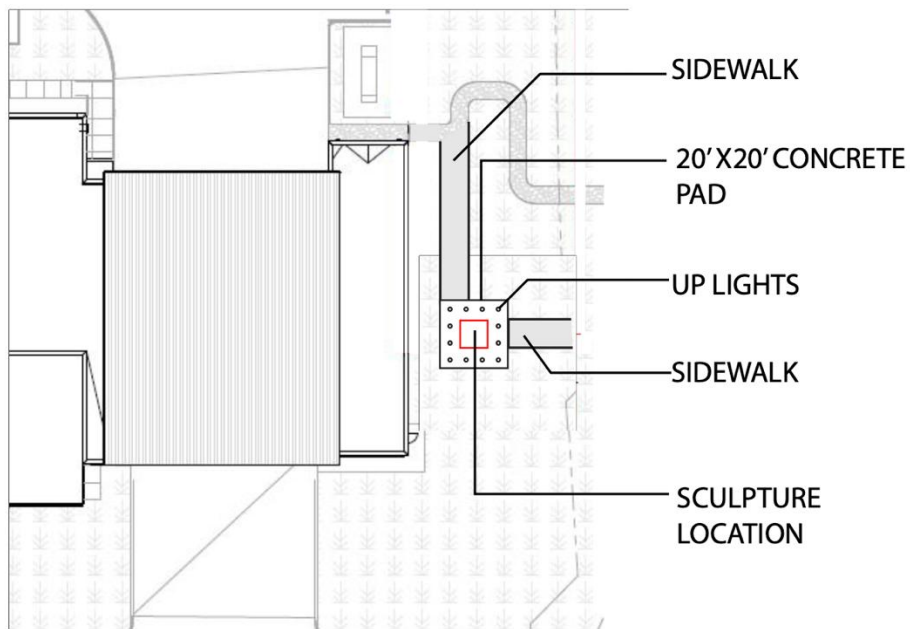

PLAN VIEW - NTS

SPECIFICATIONS:

MATERIALS:

WELDED METALS- MILD STEEL, STAINLESS STEEL,  
CORTEN RUSTED STEEL

PAINT FINISHES:

POLYURETHANE AUTOMOTIVE PAINT  
FINISHES & CLEAR COATS (ONLY WHERE NEEDED)

SCULPTURE WILL BE CONSTRUCTED OF A STEEL  
FRAME WITH WELDED/FORMED STAINLESS & CORTEN STEEL ON THE SURFACE.

PROPOSED SCHEDULE:

4 MONTHS AFTER FINAL  
DESIGN AND ENGINEERING/APPROVALS

MAINTENANCE:

CORTEN STEEL DOES NOT REQUIRE  
MAINTENANCE AS IS MEANT TO RUST  
NATURALLY.

THERE IS NO PROPOSED MAINTENANCE  
SCHEDULE FOR THE CORTEN PORTION  
OF THIS SCULPTURE.

PAINTED STEEL/CLEARCOAT WILL BE  
PAINTED WITH AUTO PAINT WHICH  
SHOULD LAST UPWARD TOWARDS  
20 YEARS. IF NEEDED-WILL MASK OFF  
AND REPAINT IN THE FUTURE.

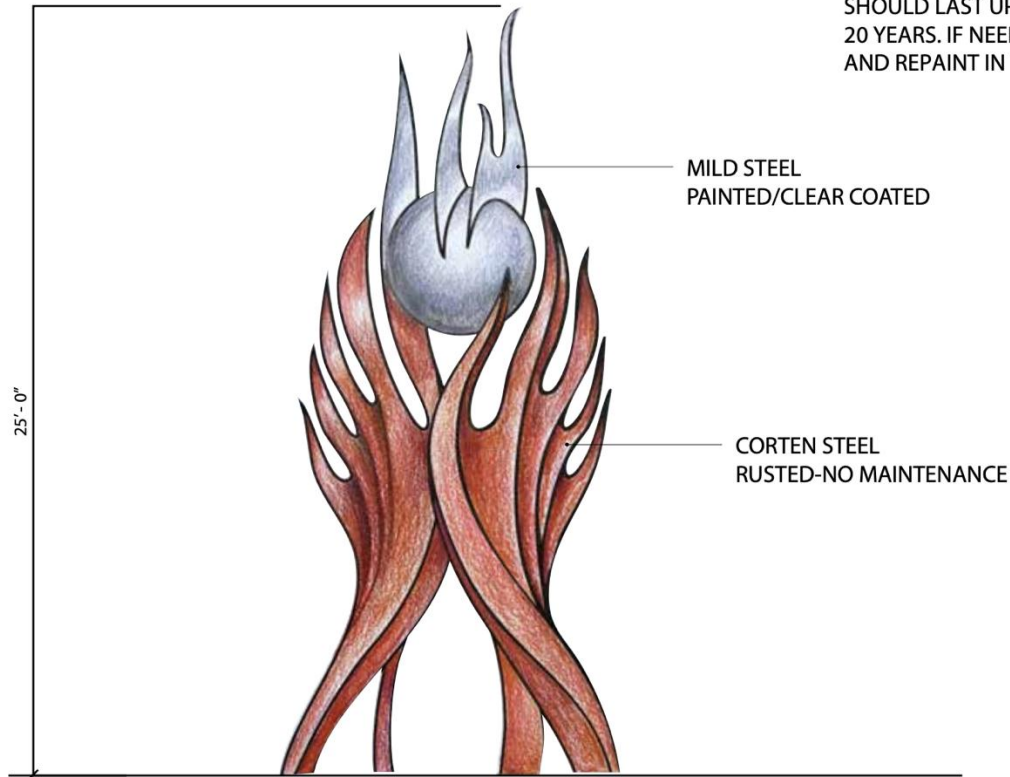

COST BREAKDOWN: \$182,000

ENGINEERING: \$10,000

UNDERGROUND POWER AND LIGHTING: \$12,000

PAVING & CONCRETE FOOTINGS: \$20,000

METAL: \$28,500

EQUIPMENT RENTALS: \$5,000

LABOR/CONSTRUCTION: \$107,000

**NOTE: LIGHTING WILL ALLOW FOR COLORED LIGHTS TO  
DISPLAY WHEN EMERGENCY CREWS ARE DEPLOYED. THE  
LIGHTS WILL REFLECT OFF THE METAL SURFACES, CREATING  
A DYNAMIC INTERPLAY OF HIGHLIGHTS AND SHADOWS THAT  
ENHANCES THE SCULPTURE'S DEPTH AND MOVEMENT AS PEOPLE  
DRIVE/WALK PAST.**



FIRE STATION - 6  
ART LOCATION PLAN



ELEVATION VIEW - NTS

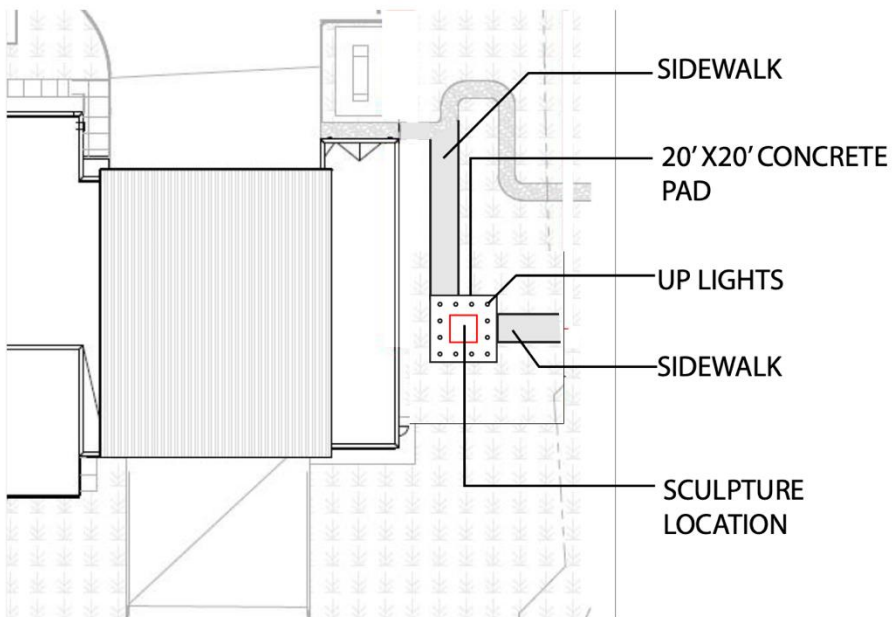

PLAN VIEW - NTS

**SPECIFICATIONS:**

**MATERIALS:**

WELDED METALS- MILD STEEL, STAINLESS STEEL,  
CORTEN RUSTED STEEL

**PAINT FINISHES:**

POLYURETHANE AUTOMOTIVE PAINT  
FINISHES & CLEAR COATS (ONLY WHERE NEEDED)

SCULPTURE WILL BE CONSTRUCTED OF A STEEL  
FRAME WITH WELDED/FORMED STEEL ON THE SURFACE.

**PROPOSED SCHEDULE:**

4 MONTHS AFTER FINAL  
DESIGN AND ENGINEERING/APPROVALS

**MAINTENANCE:**

CORTEN STEEL DOES NOT REQUIRE  
MAINTENANCE AS IS MEANT TO RUST  
NATURALLY.

THERE IS NO PROPOSED MAINTENANCE  
SCHEDULE FOR THE CORTEN PORTION  
OF THIS SCULPTURE.

PAINTED STEEL/CLEARCOAT WILL BE  
PAINTED WITH AUTO PAINT WHICH  
SHOULD LAST UPWARD TOWARDS  
20 YEARS. IF NEEDED-WILL MASK OFF  
AND REPAINT IN THE FUTURE.

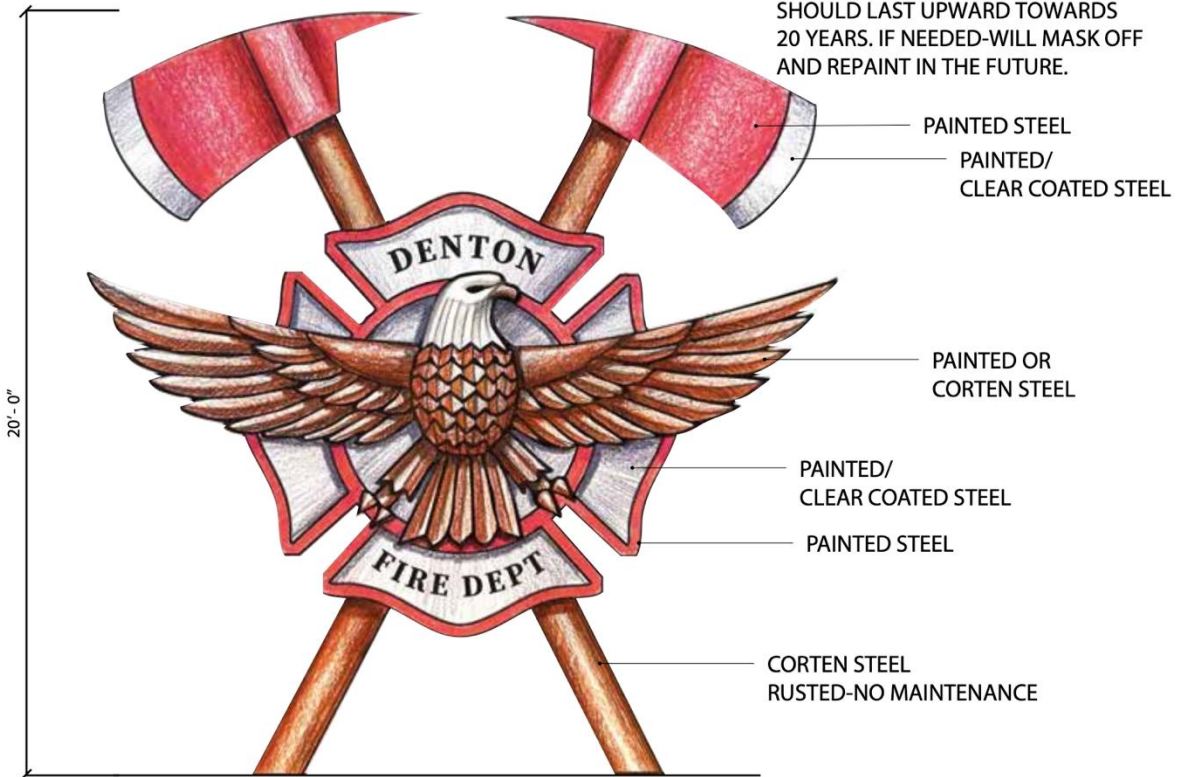

**COST BREAKDOWN: \$157,000**

ENGINEERING: \$10,000

UNDERGROUND POWER AND LIGHTING: \$12,000

PAVING & CONCRETE FOOTINGS: \$20,000

METAL: \$30,000

EQUIPMENT RENTALS: \$5,000

LABOR/CONSTRUCTION: \$80,000

**NOTE: LIGHTING WILL ALLOW FOR COLORED LIGHTS TO  
DISPLAY WHEN EMERGENCY CREWS ARE DEPLOYED. THE  
LIGHTS WILL REFLECT OFF THE METAL SURFACES, CREATING  
A DYNAMIC INTERPLAY OF HIGHLIGHTS AND SHADOWS THAT  
ENHANCES THE SCULPTURE'S DEPTH AND MOVEMENT AS PEOPLE  
DRIVE/WALK PAST.**

FIRE STATION - 6  
ART LOCATION PLAN



ELEVATION VIEW - NTS

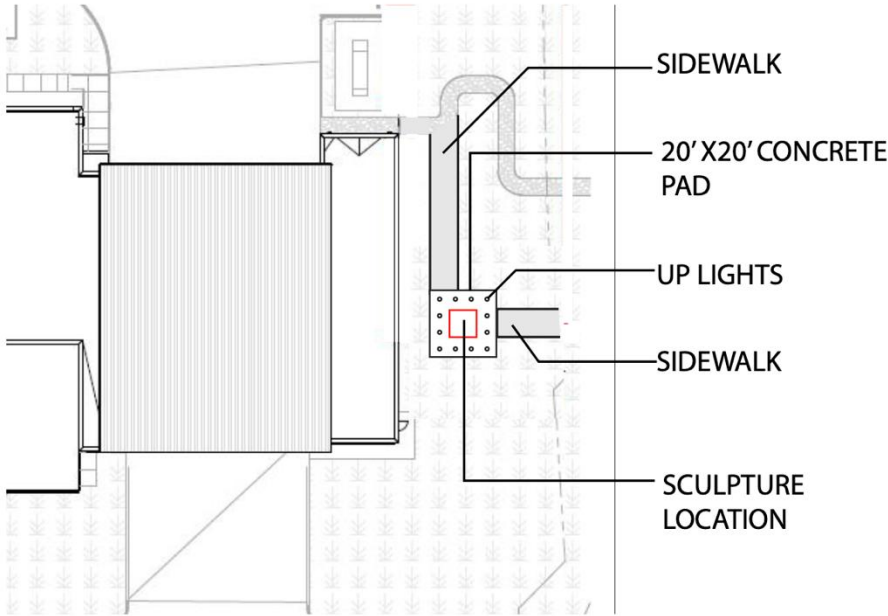

PLAN VIEW - NTS

12. Art Garcia / Graphic Content  
Dallas, Texas  
Total Cost: \$200,000

Art Garcia

LETTER OF INTEREST

City of Denton  
Denton - Purchasing  
901-B Texas Street  
Denton, TX 76209

Fire Station 6  
RFP-8774

June 30, 2024

Members of the Art Selection Committee,

This submission is presented on behalf of Art Garcia, in regard to the opportunity to create an original unique artwork for Denton Fire Station 6 to be completed and installed by October, 2026 with an all-inclusive budget total of \$200,000.

As Lead Artist for Graphic Content, Inc. Garcia has more than 35 years of experience creating innovative, sight specific works. Graphic Content, Inc. President Art Garcia is deemed to have the experience and expertise in public art and qualified to provide the services required by municipalities and their respective Public Art Committees and Institutions. Including but not limited to insurance coverage, consulting, permitting, zoning, environmental, historic or other policies and ordinances.

Like a fingerprint, every community has its own cultural, environmental or spiritual identity. This inspiration is essential to Garcia's work. With research and a strong desire to establish a visual dialog with the community, public art projects provide an iconic representation, resulting in civic pride and inspiring interaction — a sense of being. Most meaningful are the intangible connections the object makes with the viewer and the community in which they exist, encouraging both gathering and place making.

*Zarape*, 2018, for Victory Forest Community Center in Fort Worth, Texas, speaks to this process. Abstract whimsical profiles represent community members through a traditional Mexican sarape. *Seventh*, 2010, speak to the unsung heroes of the community while the Seventh Line was in service. Both projects are examples of an approach applied to Fire Station 6.

In addition to creating sculpture, Garcia has experience producing artwork for Fire Stations which speak to their communities. A professor of art and sculpture, his work has been published in the United States and Europe. In 1998, he founded Graphic Content to support private, public and commercial endeavors. A teaching instructor with the National Center for Construction Education and Research through Dallas College, Garcia earned his Master of Arts and Master of Fine Arts from the University of Dallas.

Kind Regards,

Art Garcia, MA, MFA  
Lead Artist, President  
Graphic Content, Inc.



**Concept:** The working concept of the artwork is to honor firefighters, specifically those of who have made contributions to the Denton Fire Department. This proposal seeks to showcase seven watering pools in the park-like setting at Fire Station #6, allowing individuals to reflect in a 70' path of river aggregate along the fire station. These 10' to 12' tall pool shape objects are made of steal and lucite.

**Description:** The installation utilizes seven objects created in custom metal and lucite providing low maintenance composites. The top water feature is laser cut metal and lucite. Fabricated in metal with a custom anchor system approved by a Texas Certified structural engineer and mounted on a concrete base. The individual objects are powder coated in hues reflecting water in cool blue hues. At dusk blue flood lighting will illuminate the sculpture surfaces. When on call, each sculpture will alterate white and blue traveling through the row of seven until the firefighters return from the call. While durable, the artwork will also be easily reproduced and repaired in an event of damage due to outside forces. The artwork is viewable from any direction at a location previously identified by the city to consider artwork placement.

The design process is typically completed in three phases: design, fabrication and installation. Design phase considers all aspects of the sculptures aesthetic approach as it relates to the public art realm. The fabrication phase will overlap the design phase in consideration of anchoring, fastening and welding in addition to the application of pigment. In this case, powder coating for durability. Installation occurs with two to three site visits to confirm the proper footings or pads are accurately prepared to accommodate the sculpture(s). Installation may occur with an a crew of 3 of 5 or outside contractor. Art Garcia is involved in every aspect of these phases. There is no additional personnel identified at this time, as the objects are custom built. Personnel will be selected that are best suited for their craftsmanship, timeline and task at hand with a suitable subcontractor(s).

A successful consultant, Art Garcia's quality control and quality assurance is evident in past projects. All work is carefully cross referenced with the engineer's drawings and plans originally created by Art Garcia, modified and finally stamped by a Texas Certified engineer. If at any given point during fabrication the work requires altering the engineer will be notified for final approval, re-stamped and certified if required. Garcia sculptures are completed to specification. An expertise of the artist's characteristics.

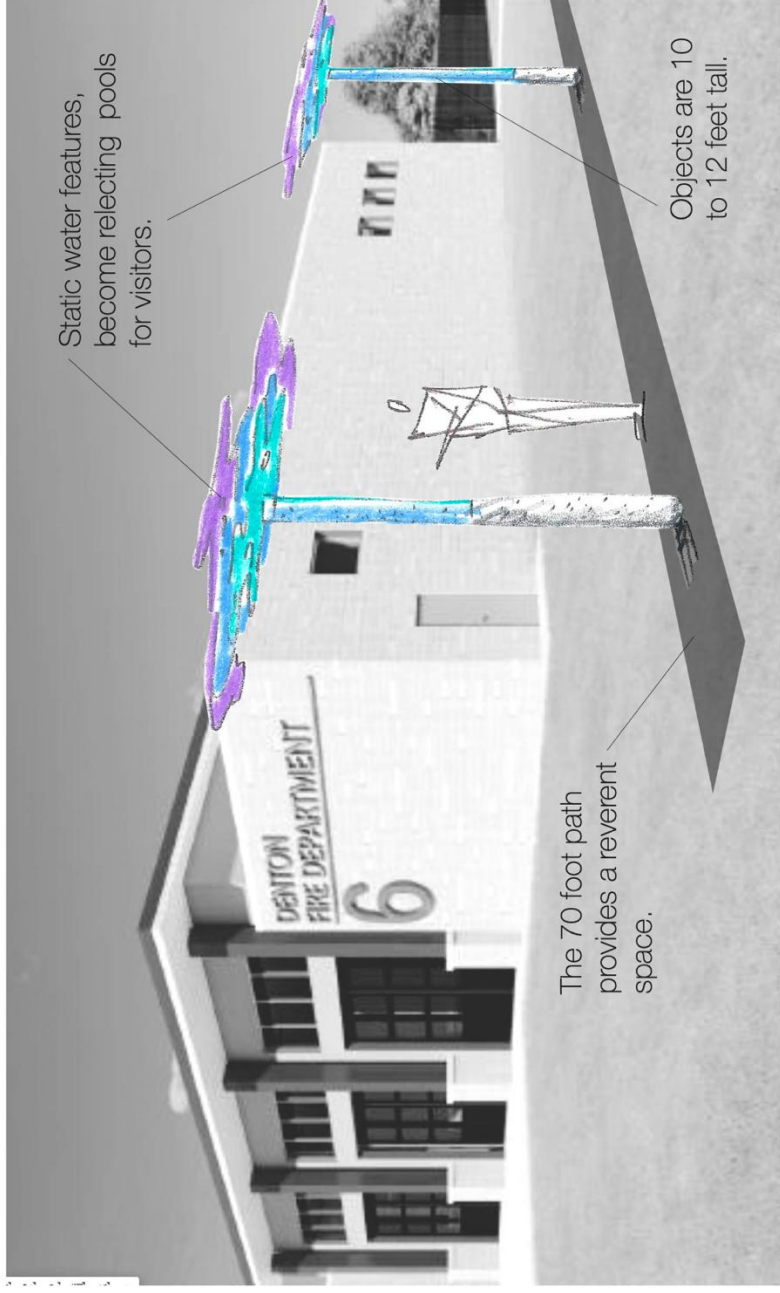

**Reflection Pool**

Sculptural fountains adorn the park-like space with a 70' path of river aggregate providing visitors a time to reflect while honoring our first responders.



Object are lit with a blue hue to accentuate pools of water.

Blue lights alternate to white during responder calls.

Ground flood lights are flush mounted at ground level.

Teasley Elevation

### Reflection Pool

During evening hours the metal and lucite objects provide a calming display of light with soft changes of blue to white light during first responder calls. When responders return the lights remain blue.

Powder coated metal and transparent lucite water shapes

10' to 12' powder coated poles suspend water shapes.

Pole anchors to piler under-ground level.

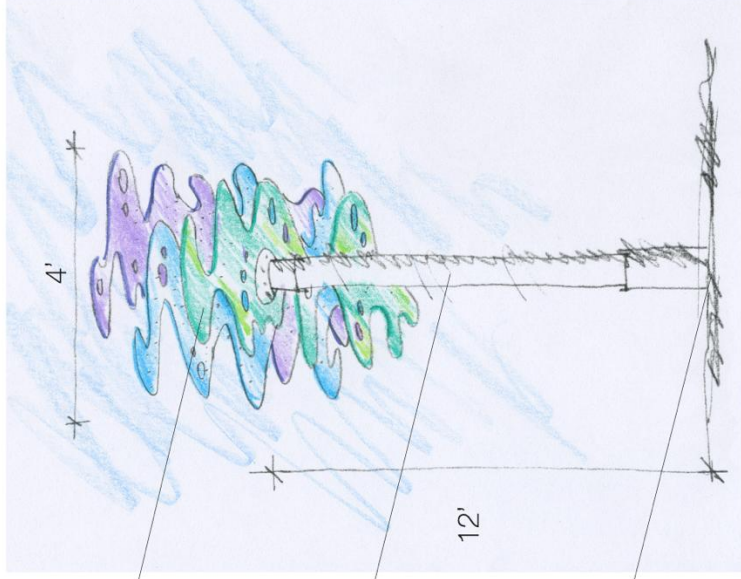

Front Elevation

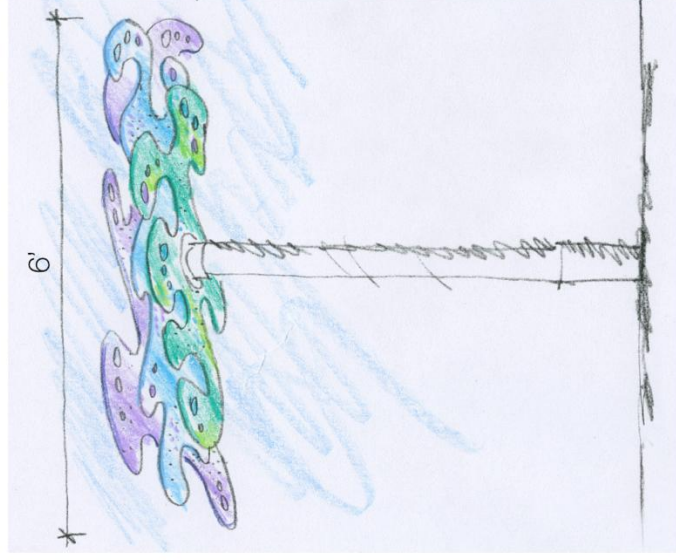

Profile Elevation

### Reflection Pool

The installation utilizes seven objects created in custom metal and lucite. While durable, the artwork will also be easily reproduced and repaired in an event of damage due to outside forces.



## Budget Outline

The artwork will utilize metal, plasma cut, powder coating. Properly constructed, the installation will require very little maintenance, though its appearance can be preserved, and the lifetime of the coating extended by periodic cleaning and waxing.

<b>Project Coordination</b>	<b>Schedule</b>	<b>Fee</b>
<b>Artist's fee</b>		
Preliminary design (artist's fee in preliminary design contract TBD)		\$ 5,000.00
Final design (artist's fee in final design/commission contract TBD)		\$ 5,000.00
<b>Consultants/Other People-Related Costs</b>		
Engineering (structural)	60 days	\$ 10,000.00
Photographer	3 days	\$ 2,000.00
Computer art preparation,	60 days	\$ 7,000.00
Model, digital maquette	20 days	\$ 5,000.00
Fabrication	120 days	\$ 25,000.00
<b>Transportation</b>		
Travel	3 days	\$ 1,000.00
Shipping of materials to fabrication site	15 days	\$ 6,000.00
Shipping of artwork to installation site	5 days	\$ 3,000.00
<b>Materials</b>		
Metal	8 days	\$ 20,000.00
Fasteners and anchors	10 days	\$ 2,400.00
Painting/powder coating	30 days	\$ 20,000.00
<b>Site Preparation</b>		
Site survey/meetings	5 days	\$ 3,000.00
Installation Labor/Equipment	20 days	\$ 30,000.00
Rentals (lifts, special equipment/materials, studio supplies, etc.)	3 days	\$ 6,000.00
Permits	10 days	\$ 2,000.00
Installation Labor	5 days	\$ 23,000.00
<b>Insurance Coverage</b>		
Loss/theft/damage (supplies and fabrication parts prior to shipping and during shipping-inland marine)		\$ 1,000.00
General liability (self, subcontractors, assistants)		\$ 600.00
Workers' compensation for assistants		\$ 1,000.00
Automobile and any special insurance riders		\$ 2,000.00
<b>Contingency (10%)</b>		\$ 20,000.00
<b>Total Budget</b>	<b>377 days</b>	<b>\$ 200,000.00</b>

Art Garcia, Graphic Content, Inc. agrees to the scope of work and budget of \$200,000. Acknowledges and agrees to comply with all applicable federal, state and local laws, regulations and grant requirements associated with NEA funding.

The estimated completion date of 10/2026 is achievable. An additional six-month contingency is an adequate timeframe for undetermined factors like weather, material availability, engineering, construction, and city permit approvals.

13 Jenn Garrett  
Newberry, FL  
Total Cost: \$100,000



## Artists Statement

As a public artist, I create sculptural installations that are rooted in place, shaped by community, and driven by narrative. My work engages themes of identity, resilience, and public service, often honoring the quiet heroism embedded in the everyday fabric of civic life. Through scale, material, and interaction, I aim to create artworks that resonate deeply—transforming public space into landmarks of meaning and memory.

Over the past 15 years, I have had the privilege of developing major public works across Florida and beyond, including pieces that celebrate first responders and the spaces they safeguard. My illuminated sculpture for Gainesville Fire Station 1, for example, honors the bravery and commitment of firefighters with a billboard-sized, light-responsive installation that has become a cherished part of the community. Its importance was affirmed when, during the construction of a new facility, the community insisted the artwork be relocated and preserved—an acknowledgment of the sculpture’s emotional and cultural impact. I have also created pieces like the Young Pine Park sculpture in Orange County, commemorating the opening of the county’s first inclusive playground, and reinforcing themes of access, empathy, and unity.

In developing works for fire stations and civic sites, I am particularly drawn to themes of heroism, selflessness, and the rich, often underrecognized histories of firefighting in Texas and across the United States. I see these projects as opportunities to both honor service and spark curiosity—to create spaces where the public can reflect on the human stories behind the sirens. My proposed work for Denton may include a responsive lighting component that is activated during emergency calls at the fire station, creating a visible, poetic gesture that links the physical sculpture with the living actions of those it honors. This approach—merging symbolism with interactivity—underscores my larger philosophy as a public artist: that art should not be passive. It should respond, engage, and bear witness. There is even opportunity to model the figure shown after a person of your choosing. For a city like Denton, with its forward-thinking approach to public art and its commitment to civic storytelling, I envision a permanent, iconic installation that is both visually powerful and emotionally resonant. A piece that honors the past, reflects the present, and stands as a beacon of shared values—community, courage, and care. Public art is most powerful when it becomes part of a city’s rhythm, identity, and story. With this work, I aim to create a sculpture that is not just seen—but felt—by generations to come.

Jenn Garrett

sketches/renderings

jgarrett



Sculpture can be mounted to wall or designed to be installed on posts adjacent to wall.

sketches/renderings







## BUDGET

Artist Fee (including concept and design development, site visits, meetings, insurance)	\$20,000
Design Documents	\$2,500
Engineering	\$3,500
Materials and hardware	\$20,250
Fabrication (appx 6 weeks)	\$36,000
Finishes	\$9250
Transportation	\$4500
Installation	\$3,500
Signage/Plaque	\$250

**Total: \$100,000**

"Jenn Garrett approached our call with great enthusiasm and passion to understand the environment and issues so that she could make a proposal that was just what we needed. And then she executed the work on time and on budget even in the midst of other projects."

-Terry Olson  
Director  
Orange County Arts &  
Cultural Affairs

14. Jennifer Troice  
 Dallas, TX  
 Total Cost: \$177,000

JENNIFER TROICE

LETTER OF INTEREST

Dear Selection Committee Members,

I'm excited about the chance to design a monument honoring our brave firefighters and their selfless sacrifice for the Denton Community. This opportunity feels perfectly aligned with my artistic language, creative energy, and passion for sculpting meaningful, community-centered public art.

**WHY ME?**

I'm Jennifer Troice, a bronze sculptor with a gift for creating emotional connections through clean, modern forms. My substantial body of work includes multiple monumental sculptures.

My outdoor monumental sculptures, dating back to 2014, remain beautiful and timeless. Bronze is weather-resistant, requiring minimal maintenance. Safety is implicit in this format - size, weight, and strength. Installations are anchored with underground structures and cement, guaranteeing they won't fall over even if climbed on.

Working with board representatives, community, and business leaders is not new to me. I thoroughly enjoy the collaboration, from project launch to final installation. My life experience makes me particularly adept at listening, understanding, and incorporating input.

**RELEVANT EXPERIENCE**

To date, I have completed 14 public and private life-size bronze sculptures, including custom, site-specific, and community-responsive works.

I was commissioned to create THE VERACRUZ COLLECTION, an eight-sculpture series for a public park. The theme was celebrating human connection. The idea is that spending time on devices pulls us apart, while being outdoors playing brings us closer. One monument shows two figures playing jacks, together and fully present (JACKS). Another depicts a seesaw with an empty seat. Visitors frequently interact and play with the bronze child, and lots of photos are taken (SEESAW).

Each sculpture explores human relationships—friends, family, neighbors—all interacting outdoors, face-to-face. It's a reminder of the beauty in real connection, without screens in between. It was important to me that the sculptures be visibly and physically enjoyed.

Likewise, I've also designed, sculpted and installed a 10 ft. tall sculpture of a tree (TREE OF LIFE) weighing over 1 ton giving me the experience of installing large sculptures using a crane.

**DESIGN & IMPLEMENTATION OF THE WORK**

At project launch, I gather insight to ensure a full understanding of the vision.

Second, I create a small 3-D format model of the proposed sculpture to enable suggestions or changes before crafting the full-scale sculpture.

Once the design is finalized, I begin site construction planning with my team.

I can't wait to learn more about your dream sculpture and am excited to bring it to life! I am available for meetings and to work within the budgetary and time constraints proposed. I hope my extensive experience, creativity, and ability to respond to unforeseen bumps give you the peace of mind that the outcome we create will be exceptional.

Warm regards,

*Jennifer Troice*  
 Jennifer

DESIGN PROPOSAL

I envision a bronze sculpture of 2 firefighters responding to a call. The water coming out of the hose is composed of a glass piece created by Carlyn Ray (Dallas glass artist) and will light up whenever the fire alarm goes off. The base is a representation of the cement foundation and can be adjusted in shape, size and/or material.



\*I'm happy to modify the design if this isn't what you envisioned.

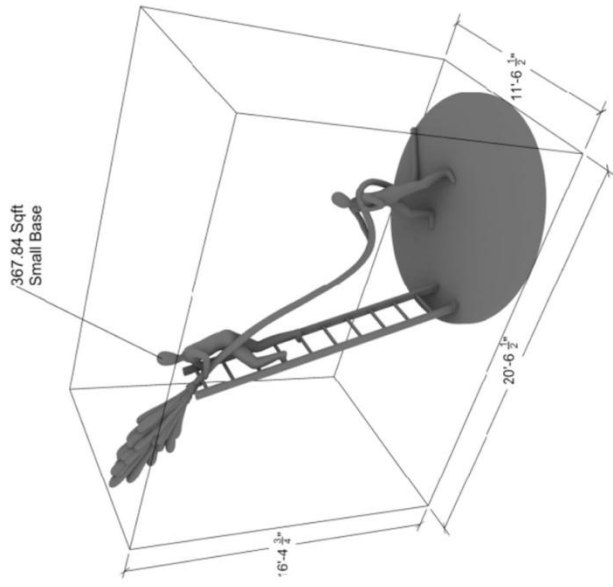
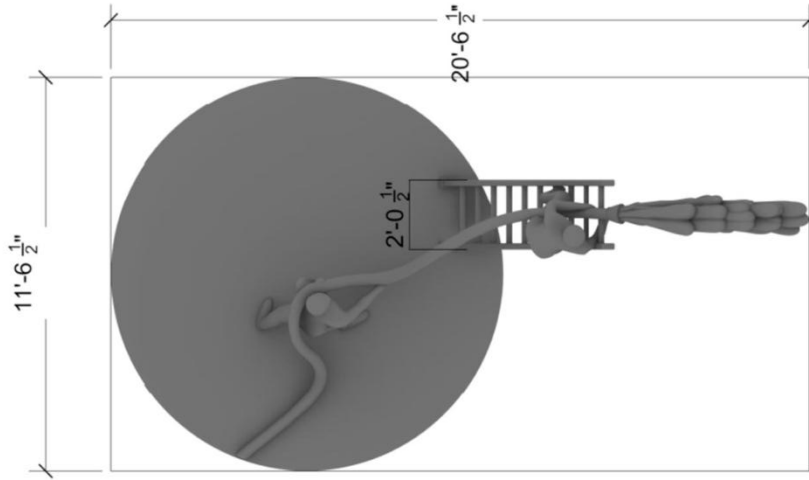

#	Product or service	Description	Qty	Rate	Amount
1.	<b>Artist Fees</b>	Proposal, Design, Creation and Project Management, Gas for traveling to and from the foundry as well as the job site. This also covers any unforeseen expenses.	1	\$35,000.00	\$35,000.00
2.	<b>Digital Design and Print</b>	Design of 3D hollow large scale model in castable material and shipment to foundry	1	\$30,000.00	\$30,000.00
3.	<b>Bronze Casting</b>	Bronze Casting, Stainless Steel Structure, Welding, etc.	1	\$78,000.00	\$78,000.00
4.	<b>Glass &amp; Electrical Component</b>	Design, Engineering and Creation of the glass water sculpture that exits the water hose and will turn on when the alarm goes off at the station.	1	\$20,000.00	\$20,000.00
5.	<b>Installation</b>	Staff, Transportation of Artwork & Equipment	1	\$14,000.00	\$14,000.00
				<b>Total</b>	<b>\$177,000.00</b>



15. Julie Libersat Studio  
Denton, TX  
Total Cost: \$2,000



## **SAFETY MOVES - PUBLIC ART PROPOSAL**

Fire Station #6 Teasley Ln, Denton TX

### **CONCEPT PROPOSAL:**

*SAFETY MOVES* is a public art proposal for the City of Denton at Fire Station #6 located on Teasley Lane. Made up of multiple stacked spinning signs, *Safety Moves* is inspired from the patterns in safety symbols and roadways. The artworks engage with the wind, each layer of signs turn individually on ball bearings acting like a windmill.

Installed in a cluster near the Fire Station #6 on Teasley Lane, *Safety Moves* references the symbolism of safety symbols and the heroic work of firefighters and safety personnel. The installation seeks to create a space that inspires visitors and commuters to reconsider our contemporary urban landscape, street markings, and safety symbols. My intent is that visitors are drawn to walk through and around *Safety Moves*, feeling inspired to navigate around or through road signs and consider how they direct our movement. Presented at a smaller scale, the spinning signs allow participants to experience urban space from a different vantage point and hopefully inspire creative physical interactions. The installation seeks to engage pedestrians and drivers to reconsider the everyday landscape traversed on their commutes through and on roads.

*Safety Moves* is visually engaging during the day as well as at night. The reflective surfaces of the signs interact with light at night from passing vehicles and on site lighting. Headlights from

passing vehicles on both roadways will engage with the reflective sign material to create visually interesting movement and interaction. A new addition to the installation will be electrical components including flashing sirens lights that flash when the fire alarm is activated.

This proposal includes modification and addition to an existing public artwork commissioned by the Rose Kennedy Greenway Conservancy in Boston, MA. Originally titled, “No Direction,” this public artwork was commissioned in 2018 and installed for a temporary public art exhibition in the Greenway Conservancy from June to November, 2018. The work was commissioned for “The Auto Show” which was curated by Lucas Cowan to commemorate the park’s 10 year anniversary as an outcome of a major urban infrastructure project. As the work was commissioned to be installed for only six months, after the duration of the show the artwork became my property with the Greenway Conservancy holding no rights over the work. The artwork has been in storage since 2019. It will need minor alterations to be updated for installation but the preparation of the site and installation to ensure safety will be the greatest expense. Replacing the vinyl sign material with longer lasting vinyl will be the focus of updating the work for permanent installation. The original vinyl sign material was estimated to last 10 years in full UV exposure. The work has been in climate controlled storage for 5 years but as replacing the vinyl will be part of the work’s long term maintenance and conservation plan, installing it with new vinyl will ensure a consistent conservation.



Centrally installed in *Safety Moves* are spinning signs that engage the passive wind energy to move the blades of the signs like a windmill. The layers of signs resemble a totem and reference the complex sign posts familiar from Dr. Seuss or the Wizard of Oz. The stacked signs each have bisected four sides like blades of a propeller to catch the wind. Each layer moves independently on rotating cuffs. The signs utilize basic road sign shapes and colors but remain blank from marking or content so as not to be confused with road signs located in the vicinity. The surface of the signs are covered in reflective vinyl which engages with car and street lights at night and as the sign moves with the wind.





Figure 1: Original installation on the Rose Kennedy Greenway Conservancy, June to November 2019



Figure 2: Alternate perspective of original installation

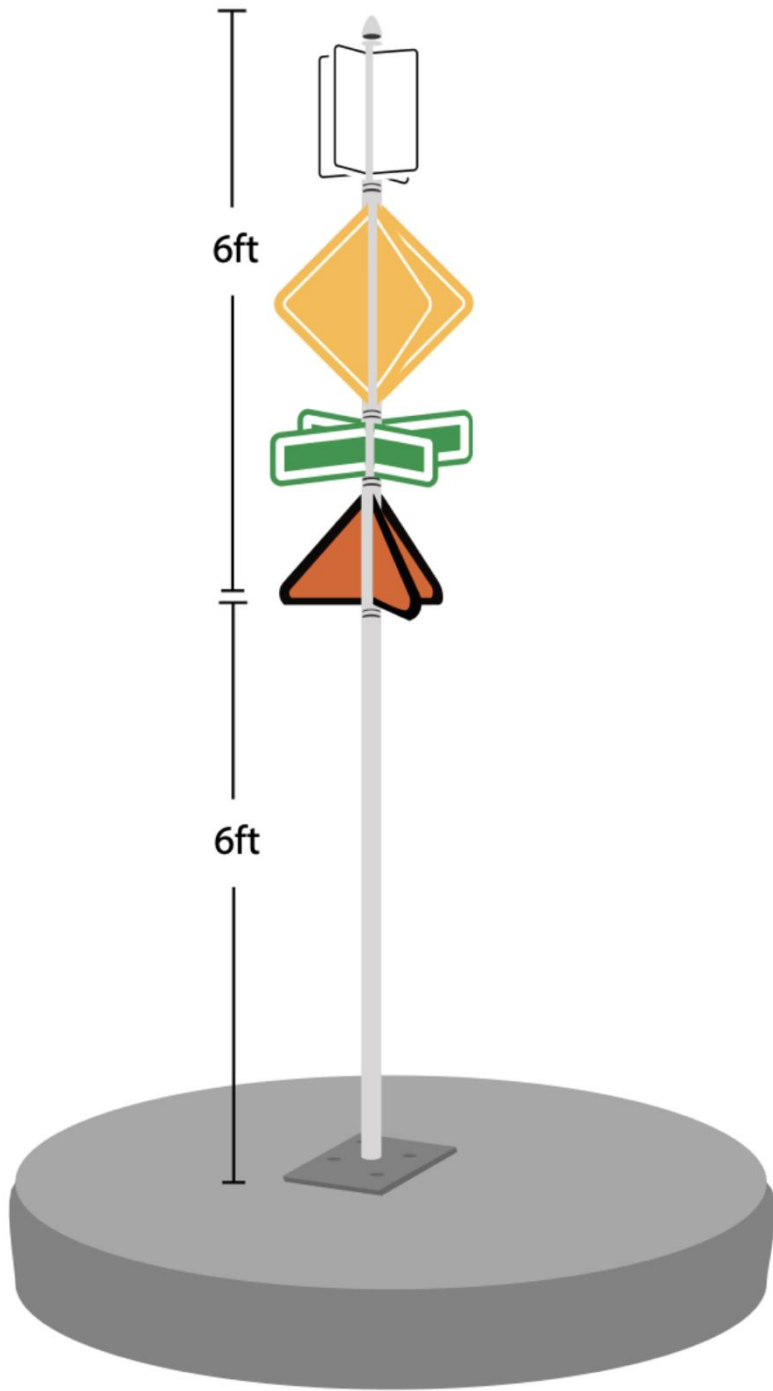

Figure 4: Schematics of Sign Posts



**PRELIMINAREY BUDGET:**

**Materials**

Existing Sculptural components (5 signs)	\$25,000
4" Structural Steel Pipe	\$1,000
Aluminum sheets	\$1,000
Replacement Vinyl	\$5,000
Siren Electrical Components	\$1,000

**Labor**

Engineering fees	\$7,000
Electrical contractor	\$5,000
Production, in-studio (vinyl replacement)	\$2,000
Fabrication offsite (siren housing)	\$5,000
Powder Coating	\$1,000

**Installation**

Sign Installation	\$2,500
Electrical Installation	\$5,000
Cherry Picker rental (3 days)	\$5,000
Transportation to site	\$500

**Site Preparation**

Concrete Pads	\$30,000
Landscaping	\$5,000
	\$35,000

**Additional Expenses**

Insurance	\$2,500
Contingency costs	\$10,000
Artist Fee	\$10,000

**TOTAL ESTIMATED BUDGET** **\$158,500**

## Julie Libersat

Artist Statement

julielibersat.com

I use navigation and orientation as both metaphor and process in order to examine our relationship with the built environment. I question my own relationship to place and belonging through the lens of "getting lost," which allows me to highlight the ways that public and private spaces direct orientation and inform our cultural values. Our cities, neighborhoods, and buildings reflect our personal, cultural, and political histories and imaginaries. Individually, places hold great meaning: we occupy places within our memories, dreams and imagination. I strive to make immersive, interactive, and participatory environments that engage viewers and compel them to observe ways in which space is socially and culturally produced.

Through digitally fabricated sculptures, installations, videos, and interactive technology, I explore patterns and symbols within the visual culture of transportation to reveal the politics of space. *No Direction* explores infrastructure history is a public artwork commissioned by the Greenway Conservancy, a 1.5-mile rooftop public park above Boston's Central Artery Expressway. To commemorate the 10-year anniversary of the Big Dig, my temporary public artwork titled, *No Direction* included five kinetic sculptures that referenced common street signs and the history of the park's construction. Each sculpture spins when activated by the wind and reflects the lights of vehicles' headlights at night.

As a visual artist, art /design educator, and scholar in the field of art education, my creative research, scholarship, and service often merge boundaries and feed into each other. My studio practice is rooted in an ongoing investigation of our relationship with the built environment: how we design, navigate, represent, and live within architecture and infrastructure. My research and writing explore our relationship and orientations within public space. A recent article titled, *The Great Highway Robbery: Texas Highways and Historic Freedmen Towns*, traces the history of urban renewal projects and their pattern of destruction through historic Black neighborhoods. I recently collaborated on a co-authored book chapter titled "Libretto in Four Acts: Tactics for Art Walking in Public Spaces," which questions if all bodies have agency and are, in fact, safe in public space, using the lenses of intersectional feminist and disabilities studies. In 2021, I served as co-PI on a National Endowment for Humanities grant project *Quakertown Stories*, which is an interdisciplinary curricular initiative that integrated the history of Quakertown, a historic Black community in Denton, into courses across TWU. In order to grapple with our own institution's complicit role in the neighborhood's

forced removal and dissolution, we worked with an interdisciplinary group of faculty fellows to create curriculum and reflect on best practices for social justice learning and arts and place-based research. We worked with students in our classes and connected with descendants of Quakertown residents, community members, and historians through programming and oral history projects.

#### BIO

Julie Libersat is a new media artist and associate professor of art, design, and technology at Texas Woman's University. She has a BFA from the Maryland Institute College of Art (2003), an MFA in New Media (2016) and a MA in Art Education (2017), both from the University of North Texas. Libersat has exhibited artwork in the US and abroad including shows at the Dallas Contemporary Museum, Texas Vignette, Currents International New Media Festival, Paseo Taos, and Museo de la Ciudad de México. She has received a Maryland State Arts Council Individual Artist Grant, the 2014 CADD FUNd grant, and the Velma and Davis Dozier Travel Grant from the Dallas Museum of Art. She served as a co-PI on a Humanities Connections grant from the National Endowment for Humanities in 2021-22.

Julie Libersat is a new media artist and associate professor of art, design, and technology at Texas Woman's University. She has a BFA from the Maryland Institute College of Art (2003), an MFA in New Media (2016), and a MA in Art Education (2017), both from the University of North Texas. Libersat exhibits in the US and abroad including at the Dallas Contemporary Museum, Paseo Taos, and Museo de la Ciudad de México. She has received a Maryland State Arts Council Individual Artist Grant, the 2014 CADD FUNd grant, and the Velma and Davis Dozier Travel Grant from the Dallas Museum of Art. She served as a co-PI on a Humanities Connections grant from the National Endowment for Humanities in 2021-22.

16. Katherine KT Taylor  
Houston, TX  
Total Cost: \$152,100

Dear Members of the Selection Committee,

I am thrilled to submit my letter of interest for the City of Denton's Fire Station #6 Public Art opportunity. As a metal sculptor with over 20 years of experience creating large-scale, permanent outdoor artworks, I am eager to propose a vibrant, iconic sculpture that honors the courage and dedication of Denton's firefighters and their enduring legacy of service to the community.

For this project, I envision a dynamic, larger-than-life sculpture featuring a horse and a Dalmatian, crafted in durable, weather-resistant metal. This concept pays homage to the historical role of horses in pulling fire carriages and Dalmatians in alerting communities and calming horses during emergencies. The horse would be depicted standing calmly, its head lowered to nearly touch noses with the Dalmatian, which gazes up with alertness and loyalty, capturing the deep bond of true friendship between them. To enhance visual impact, I would employ my signature "texture swapping" technique, integrating tactile surfaces inspired by firefighting gear—such as the weave of hoses or the grain of leather—alongside natural textures found in the Denton area.

Designed for durability in Denton's climate, the sculpture would use low-maintenance materials like stainless steel or bronze, ensuring longevity and safety. The piece would serve as a landmark that delights residents and visitors, embodying the spirit of community resilience and the vital role of the fire station. The proposed budget cover all

costs, including design, engineering, materials, fabrication, site modifications, and installation.

My recent projects demonstrate my ability to deliver impactful public art within budget and timeline constraints. I completed The Lion Family, a bronze sculpture for Easton Park in Austin, TX, and am currently fabricating a 13-foot stainless steel falcon for the University of Texas Permian Basin. These works reflect my expertise in creating enduring, site-specific art that resonates with communities. I am prepared to work closely with Denton's team, local engineers, and fabricators to ensure seamless integration and compliance with all project requirements.

you for considering my proposal. I am excited about the opportunity to contribute to Denton's artistic legacy and look forward to the possibility of further developing this concept.

Sincerely,

**Katherine 'KT' Taylor**

1707 1/2 Post Oak Boulevard #137, Houston, TX 77056

Tel: +1 979 571 5045 • Email: ktcreature@gmail.com • www.katherinekttaylor.com

## FIRE HORSE AND DALMATIAN



**Materials:** Bronze or Stainless Steel

**Size:** 10'(H)x12'(L)x3'(W) , Fire Horse

4'(H)x3'(L)x2'(W) , Dalmatian

**Budget:** \$150,000 approx.

KT-2F



# COST ESTIMATION TO FABRICATE AND INSTALL

Below and estimated itemized budget:

<b>Visit Denton's Fire Station #6</b>		<b>Packing</b>	
Travel expenses	\$ 400.00	Wooden box for transporting sculpture	\$ 1,500.00
Lodging	\$ 1,000.00	<b>Shipping</b>	
Modeling material	\$ 200.00	Shipping costs	\$ 4,000.00
<b>Create base for wax model</b>		<b>Installation costs</b>	
Create models in polystyrene	\$ 10,000.00	Equipment rental	\$ 2,500.00
<b>Create wax model</b>		Labor	\$ 4,000.00
Materials and labor	\$ 8,000.00	Foundation work	\$ 3,000.00
<b>Foundry costs</b>		Travel expenses	\$ 400.00
Create molds	\$ 4,000.00	Lodging	\$ 1,000.00
Metal cost	\$ 10,000.00	Insurance (liability and workers insurance)	\$ 600.00
Casting costs	\$ 55,000.00	Permit (if needed)	\$ 1,500.00
<b>Patina, welding and polishing</b>		Structural engineering costs	\$ 1,000.00
Assembly and welding costs	\$ 8,000.00	<b>Contingency (10%)</b>	\$ 15,000.00
Cost of Patina	\$ 500.00	<b>Artist Fees</b>	\$ 20,000.00
Polishing costs	\$ 500.00	<b>TOTAL COSTS</b>	<b>\$ 152,100.00</b>

*\*The final budget may be adjusted based on the sculpture's size and the level of detail required.*

## Samples of previous work:





17. Maxwell Emcays  
Chicago, IL  
Total Cost: \$200,000

As an artist whose practice is rooted in creating meaningful, large-scale public art that elevates community identity and celebrates public service, I am honored to submit a proposal for the City of Denton's Fire Station #6 public art initiative. This project presents a powerful opportunity to honor the bravery, service, and humanity of Denton's firefighters while contributing to a bold new era in the city's public art legacy.

My multidisciplinary public art practice is built on themes of empowerment, remembrance, and connectivity. I create immersive sculptures and installations that not only reflect the character of a site but invite community interaction and emotional resonance. With over 15 years of experience in producing impactful artworks for municipalities across the country—including Chicago, Memphis, and Grand Rapids—I understand how to deliver ambitious projects that are structurally sound, community-centered, and built to endure.

This particular commission, supported by Denton's historic 2023 Bond Program, represents more than a public art installation—it symbolizes a civic investment in the cultural fabric of the city. My artistic approach is well-suited to this charge. My works such as ASPIRE, a 25-foot monument in Chicago's Englewood neighborhood, and The Path Forward, an 80-foot aluminum and steel installation at the University of Illinois, exemplify my commitment to creating "iconic placemaking" pieces that are tailored to their environment and community values.

For Fire Station #6, I envision a visually striking installation that both honors the legacy and spirit of first responders and instills a sense of pride and reflection in the surrounding community. I plan to engage closely with city officials, fire station personnel, and residents to ensure that the final artwork is rooted in local identity while serving as a beacon of inspiration and public gratitude.

My technical process includes the use of CAD modeling for 3D design and coordination with structural engineers, fabricators, and municipal stakeholders. This ensures that the artwork meets all safety, budgetary, and environmental requirements—especially important for outdoor, permanent installations exposed to Texas weather conditions.

Public art is a tool for unification and storytelling. With this project, I aim to craft a work that reflects Denton's values—courage, community, and forward-thinking leadership—and contributes to the city's evolving artistic landscape with enduring power and purpose.

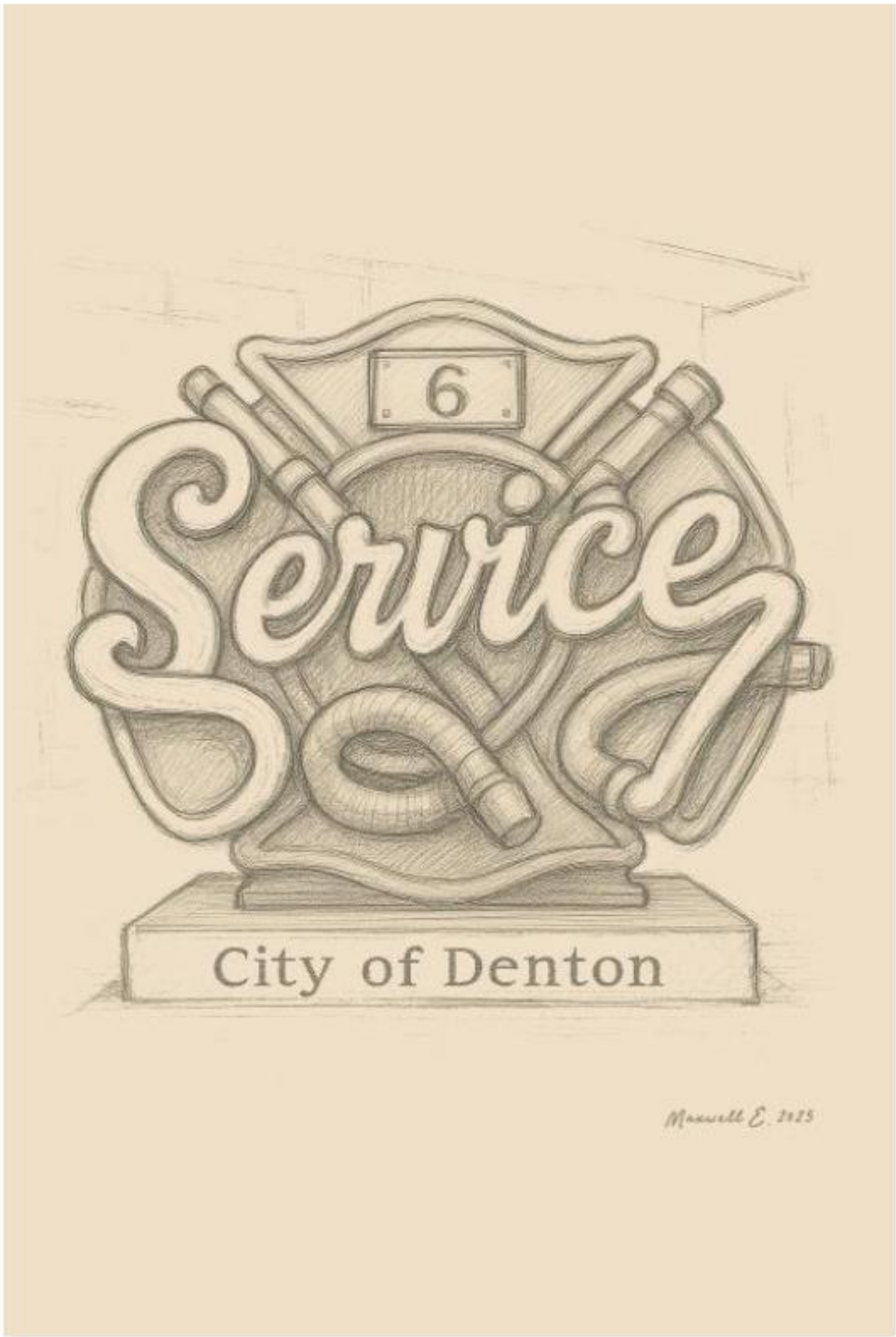



## Proposed Budget for City of Denton Fire Station #5 Public Art Project

Total Project Budget: \$200,000

Category	Details	Amount (USD)	% of Total
<b>1. Administrative Costs</b>	Insurance, project management, travel	\$10,000	5%
<b>2. Artist Fees</b>	Creative concept development, design work	\$30,000	15%
<b>3. Pre-Fabrication</b>	Engineering, modeling, shop drawings	\$24,000	12%
<b>4. Fabrication</b>	Materials & parts, shipping, fabricators, studio rental	\$76,000	38%
<b>5. Installation</b>	Site prep (concrete, trades), install labor & equipment	\$30,000	15%
<b>6. Concrete Fabrication &amp; Install</b>	Specialized base and structural foundation	\$25,000	12.5%
<b>7. Contingency</b>	Design modifications, material increases, inflation buffer	\$15,000	7.5%
<b>TOTAL</b>		<b>\$200,000</b>	<b>100%</b>

---

### Notes:

- This breakdown matches the target ranges shown in your third image:
  - Artist Fees: 15% ✓
  - Pre-Fab: 12% ✓
  - Fabrication: 38% ✓
  - Installation: 15% ✓
  - Admin: 5% ✓

18. Ken McCall Studios  
Boise, ID  
Total Cost: \$200,000

### Letter of Interest

Each public art project has its own potential, and my approach is to create a new design for each opportunity. I am a sculptor based in Boise who specializes in creating enduring works from metal. For over 25 years I have been sculpting contemporary works that combine clean, flowing lines with unexpected details. My fabrication skill set serves not only my own art but allows me the opportunity to collaborate with artists of other disciplines to design and create unique works. Regionally I have collaborated with many Boise artists on several recent projects and have worked with the nationally renowned sculptor Arthur Higgins. Some of my recent notable works are *Circuitree* for Greeley, CO *Transference* for Boise State University; a multiple sculpture design and installation for The City of Bend, OR; an entryway sculpture for the Inn at 500 in Boise, ID; *24/7* and *Call and Respond* for Fire Stations #4 and #8 in Boise, ID; a kinetic sculpture powered by the wind for Heroes Park in Meridian, ID; an iconic free-standing sculpture *Spiral of Injustice* at the Idaho Anne Frank Human Rights Memorial in Boise, ID; a kinetic sculpture representing a historic park and its relationship with the surrounding community throughout time for Munson Park in Norfolk, VA; *A New Leaf* for Bates Technical College in Tacoma, WA; a placemaking sculpture, *Pillars of the Community*, at Fire Station No. 36 in El Paso, TX; *Ambassador's Portal* at Don and Anne Davis Park in Newport, OR; a multi sculptural bench installation for a senior living center in Broomfield, CO; a roundabout sculpture of a mare and her foal celebrating the spirit of rodeo in Nampa, ID; a didactive piece commemorating the City of Nampa in the heart of downtown in Lloyd Square; an entry way sculpture celebrating community upstanders at the Wassmuth Center for Human Rights in Boise, ID; *Vita Nova* celebrating new life for Rogers Farm neighborhood in Superior, CO; and an entry way metal relief sculpture signifying how individuals in the community make up the local landscape for Monroe Detention Center in Woodland, CA.

Working in primarily metal allows the flexibility to produce both delicate and monumental objects of art that can live in almost any space. The materials I work in most often are aluminum and stainless steel which are extremely versatile for lasting outdoor installations. The meticulous construction methods that my studio employs often give a seamless quality to the art to emphasize the elegant lines of the design. Color is used carefully to enliven the space and I often incorporate other materials in the work as important details. Recent pieces have utilized gilding, mosaic, acrylic and specialized finishes to enhance the design.

Because I work from the template of an original artisan, commissioning agencies get the advantage of outstanding service that often gets lost in the vastness of many art corporations; I personally answer all of my own phone calls and emails, design all of my own artworks, fabricate all of my own designs, and work directly with the architects, contractors, engineers, neighborhood associations and city planners in a team effort. In addition, fabricating my own designs gives me the experience needed to propose designs that are feasible for the determined budget, as well as the advantage of being in better control of meeting timelines and staying within that budget as I don't have the cost of hiring someone else to build my artworks. The resulting art is a combination of artistic vision, solid craftsmanship, and careful integration of the piece in the natural setting.

I am confident in my abilities to design, fabricate and install unique artwork for The City of Denton's Fire Station 6. The skills needed to do so; meticulous craftsmanship, solid fabrication, and practical experience with permanent materials; are skills that I have been employing on many individual installations internationally. This is an exciting opportunity to create artwork that captures the essence of the community to engage, uplift and provoke thought in those who interact with it. I believe that my own artistic vision united with years of professional design, fabrication, and collaborative working experience contribute to give me extensive knowledge of working on artwork as well as combine to make me a unique candidate.

Thank you for your consideration,  
Ken McCall

## Proposal



Paying tribute to firefighters' courage, *Heroes Gateway* represents the idea of Fire Station 5 being a space that assists the men and women it houses to prepare for their valorous community service; a space that helps transform heroes.

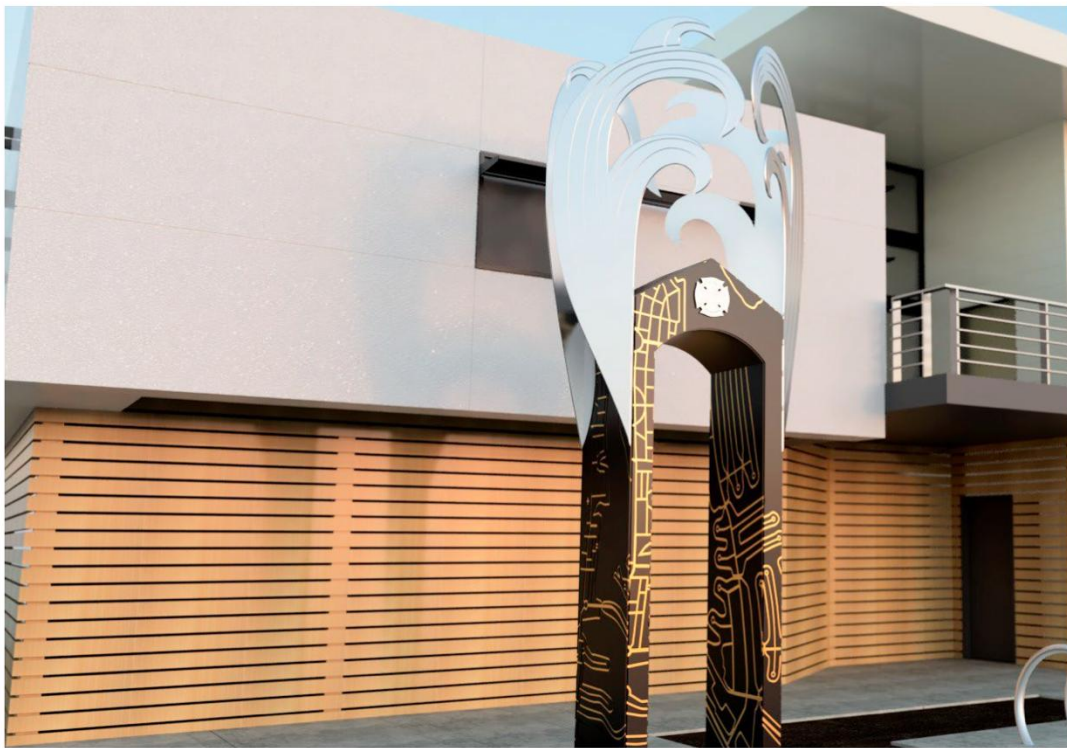



Maps of the area the fire station serves are engraved into the pillars while the station's emblem is displayed on the top, representing the relationship between the two.







Waves are used to represent the beach location of Fire Station 5 as well as signify the importance of water; the universal symbol of life and the vital resource used by the firefighters to protect it.





Blue lights will light up *Heroes Gateway*, which will turn to red to signal the station's calls.

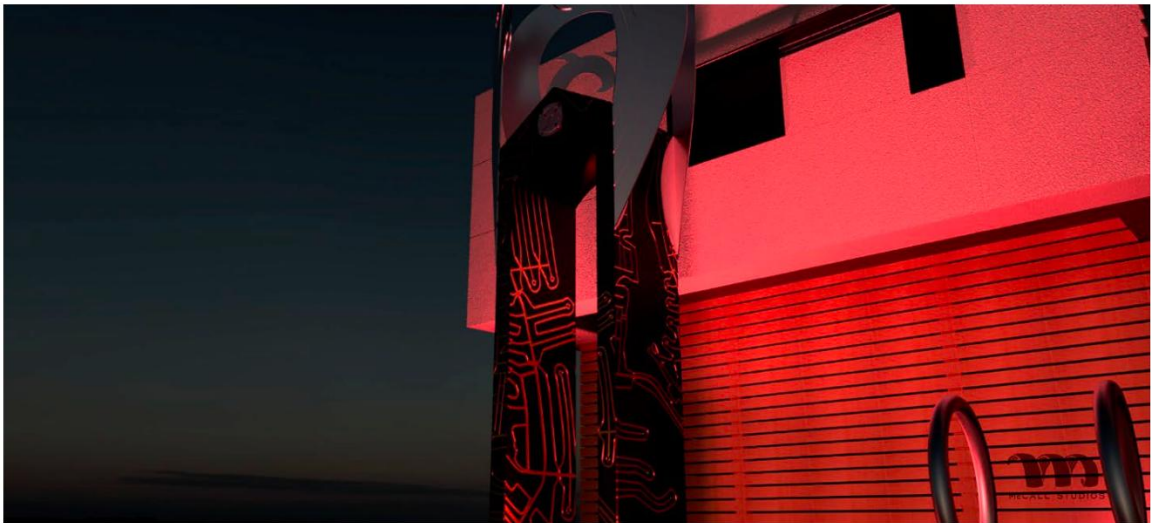



*Heroes Gateway* will stand approximately 17.5 feet high, measure about 4 feet by 4 feet at the base and 7 feet by 5 feet at the top.

### Budget

Engineering	\$2,000
Insurance	\$500
Permits/Fees	\$1,500
Materials	\$40,000
Fabrication	\$80,000
Transportation/Travel	\$10,000
Installation	\$10,000
Research/Site Installation Modification	\$26,000
Contingency	\$20,000
Artist/Design Fee	\$10,000
<b>Total</b>	<b>\$200,000</b>

19. Ray King  
Stockton, NJ  
Total Cost: \$175,000

## **R A Y K I N G**

945 Sergeantsville Rd, Stockton, NJ 08559

Tel: (215) 266-4222

[raykingstudio@gmail.com](mailto:raykingstudio@gmail.com) – [www.raykingstudio.com](http://www.raykingstudio.com)

### **STATEMENT**

I strive to create wondrous, welcoming works of art to enhance public spaces and appeal to all ages. I use the phenomena of light as an art medium, creating dynamic interactions that refract light into color. My art reflects my interest in geometry, science, technology, light and color to create luminous, interactive sculptures that welcome the public and uplift the spirits of viewers -- to make the mundane magical.

I've been a working artist for nearly 50 years with more than four decades experience in public art. My designs are site-specific, inspired by the surroundings to create a unique sense of place. I work with durable materials -- laminated safety glass, stainless steel and concrete -- to create long-lasting monumental artworks. Two common design concepts in my work are "beacons" or "lens" structures that act as optical instruments to capture and re-direct light and color projections into the surrounding space to animate the environment.

Working with glass, metals and laminating films, my sculptures are designed to interact with the sun and/or artificial light, projecting and reflecting light and color into the surrounding space, shifting color and transparency and changing appearance with the times of day and degrees of sunlight. I use the phenomena of light as it interacts with the optics of glass as an art medium, creating dynamic interactions with light, refracting it into colors -- rainbow emanations that change as the viewer moves.

I'm an extremely organized, seasoned professional, with a keen sense of organization and project management. I have experience working with teams, enjoy the R & D process and excel at structural details. Most of my projects are done in collaboration with government agencies, community groups, real estate developers, cultural commissions and construction crews. Many of my projects have involved substantial community consultation and public participation plans that range from design charrettes, school presentations for students, lectures, video productions, book publishing and tours. Public art can be a source of pride for a community as it adds beauty to the landscape. I welcome feedback to my designs -- the process generally improves the final product and generates enthusiasm from the community. I consider this intrinsic to the public art process.

Finally, my art is designed with the highest concern for safety, made from durable materials and are generally maintenance-free and vandalism-proof.



## **INTRODUCTION & INSPIRATION**

I strive to create wondrous, welcoming works of art to enhance public spaces. I use the phenomena of light as an art medium, creating dynamic interactions that refract light into color. My art reflects my interest in geometry, science, technology, light and color to create luminous, interactive sculptures that welcome the public, animate the environment, and uplift the spirits of viewers -- to make the mundane magical.

Over the past five years, I've created a series of what I call Celestial Objects. There are two main categories within these creations: dichroic glass-clad dodecahedrons and spherical structures enmeshed with laminated dichroic glass discs and a smaller stainless dodecahedron star within them. Inspired by Buckminster Fuller's 'Bucky Balls', these geodesic structures not only reflect a purity of geometry inherent to the natural world but are also considered by engineers to be the most durable structural building block available to us.

For the Denton Fire Stations' RFPs, I am proposing two luminous, cosmic sculptures:

### **G - STAR and G - SPHERE**

Both are inspired by the concept of a "Beacon," from the old English verb "to beckon to come" and a "Lighthouse" that guides and helps navigate waterways through the darkness. They are distinct, but aesthetically-related, sculptures, I am offering both versions to both Fire Station #5 and Station #6 to select one.

These free-standing geometric sculptures are fabricated and ready for installation. Made with laminated dichroic glass elements designed to interact with light to dynamically change colors depending on the angle of light and the movement of the viewer in space, the Denton Beacon(s) will be a strong and glowing visual landmark, as well as an iconographic symbol for the community. The Beacons will be visible to passers-by and from a distance to fully experience the changing colors, light projections/reflections and shadows.

The Beacons will be illuminated at night by a solar powered LED light fixture hidden within the sculpture's base. I could install programmable lighting that could b

**RAY KING STUDIO PRESENTS**

[www.RayKingStudio.com](http://www.RayKingStudio.com)

**DENTON BEACONS**



**D - STAR**



**D - SPHERE**

Two Proposals of Possibilities for Luminous Free-Standing Sculptures  
To Enhance and Animate the Denton Fire Stations #5 and/or #6

## D - STAR

Based upon the "Great Stellated Dodecahedron" -- a geometric form that creates a five-pointed star from every vantage point (see images below), G-STAR is made from a stainless steel frame and laminated dichroic glass (a thin coating developed by NASA that projects one color and reflects its opposite complement) the colors change dynamically depending on the angle of light and the viewpoint of the spectator. See video below.

[www.dropbox.com/scl/ffi/z0lgjdb39n8tqzasg80va/IMG\\_8276.m4v?rlkey=6e1kn7ntd6u3jf8bq9dm8n368&st=fxyvyp5q&dl=0](http://www.dropbox.com/scl/ffi/z0lgjdb39n8tqzasg80va/IMG_8276.m4v?rlkey=6e1kn7ntd6u3jf8bq9dm8n368&st=fxyvyp5q&dl=0)

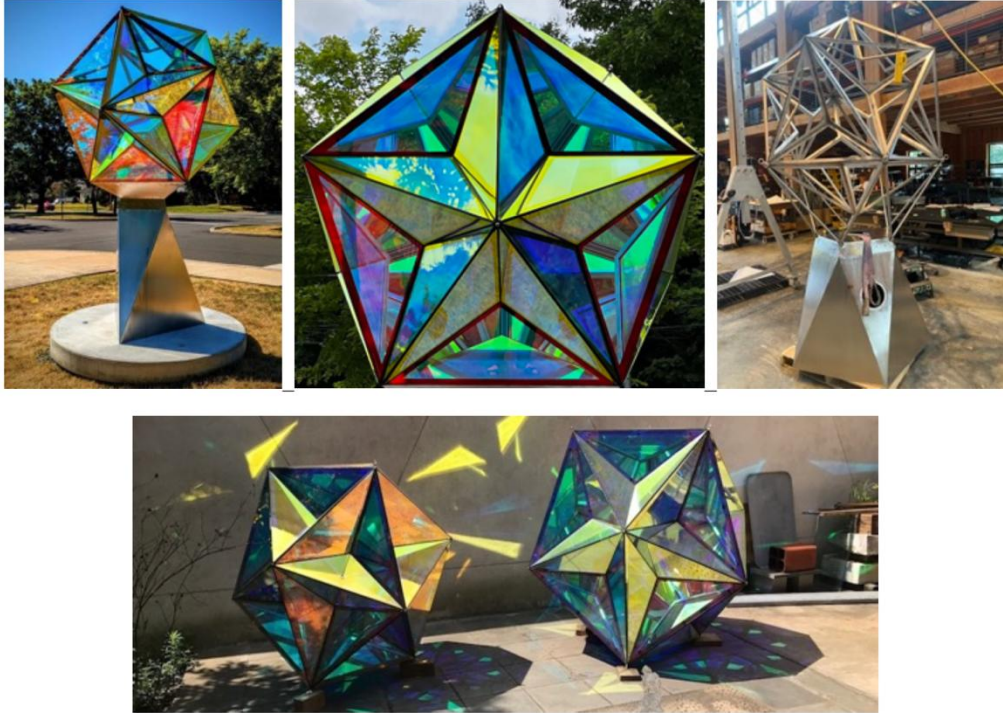







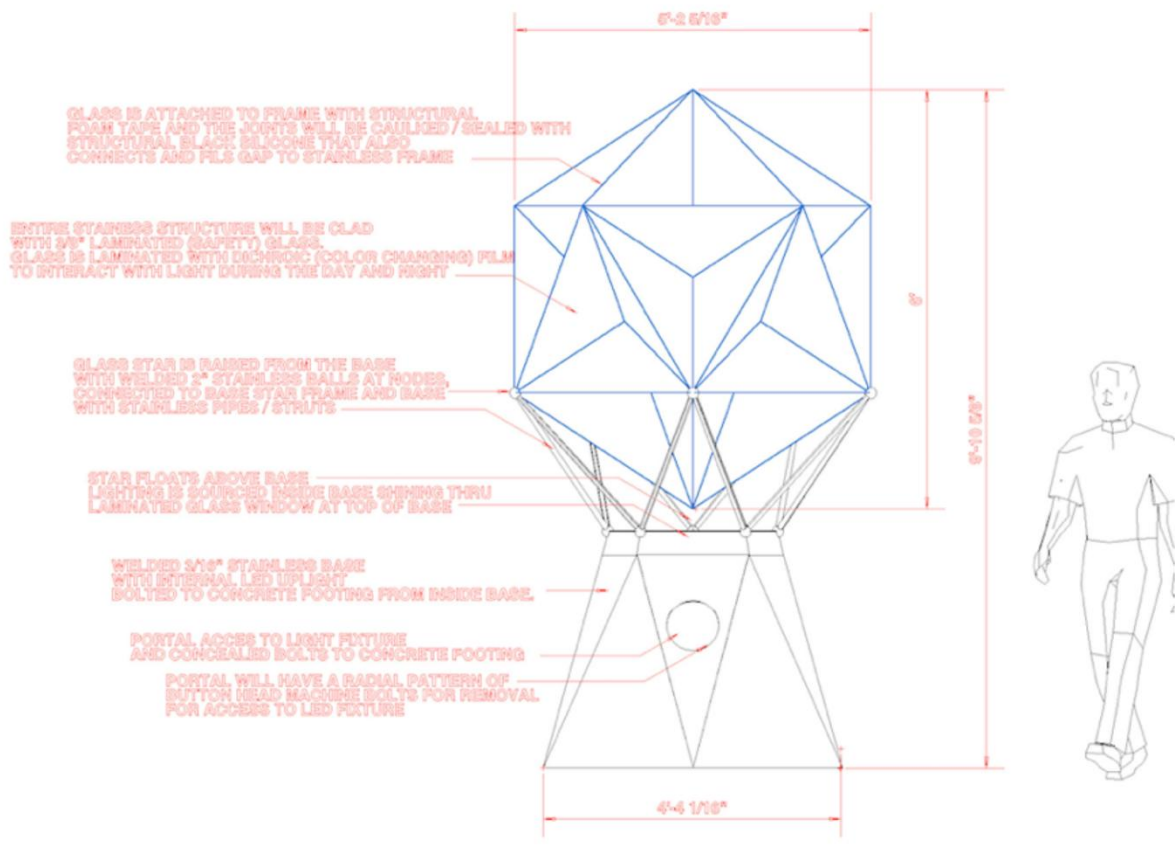

GLASS IS ATTACHED TO FRAME WITH STRUCTURAL FOAM TAPE AND THE JOINTS WILL BE CAULKED / SEALED WITH STRUCTURAL GLASS SILICONE THAT ALSO CONNECTS AND FLS GAP TO STAINLESS FRAME

ENTIRE STAINLESS STRUCTURE WILL BE CLAD WITH 3/8" LAMINATED (SAFETY) GLASS. GLASS IS LAMINATED WITH DICHROIC (COLOR CHANGING) FILM TO INTERACT WITH LIGHT DURING THE DAY AND NIGHT

GLASS STAR IS RAISED FROM THE BASE WITH WELDED 2" STAINLESS BALLS AT NODES, CONNECTED TO BASE STAR FRAME AND BASE WITH STAINLESS PIPE / STRUTS

STAR FLOATS ABOVE BASE LIGHTING IS SOURCED INSIDE BASE SHINING THRU LAMINATED GLASS WINDOW AT TOP OF BASE

WELDED 3/16" STAINLESS BASE WITH INTERNAL LED UPLIGHT BOLTED TO CONCRETE FOOTING FROM INSIDE BASE.

PORTAL ACCESS TO LIGHT FIXTURE AND CONCEALED BOLTS TO CONCRETE FOOTING

PORTAL WILL HAVE A RADIAL PATTERN OF BUTTON HEAD MACHINE BOLTS FOR REMOVAL FOR ACCESS TO LED FIXTURE



**D-SPHERE**



## B A S E S

Alternative bases can be designed.

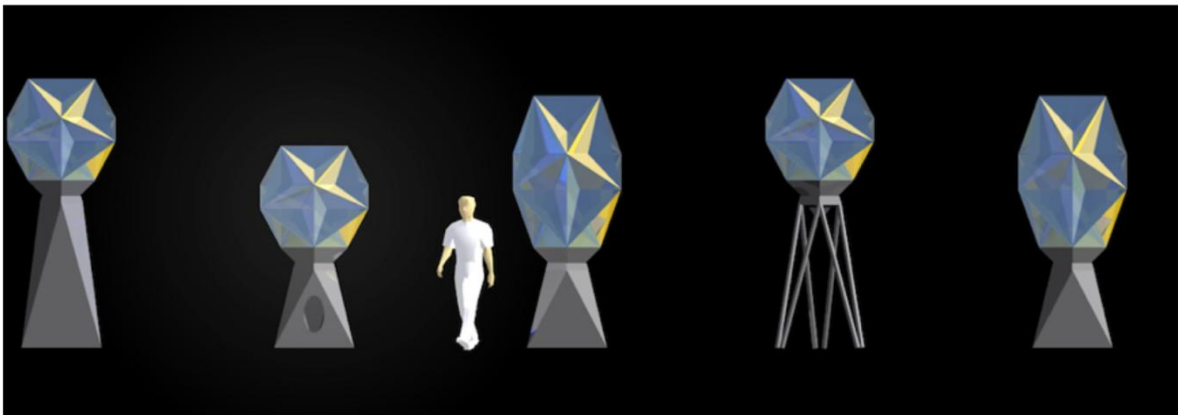
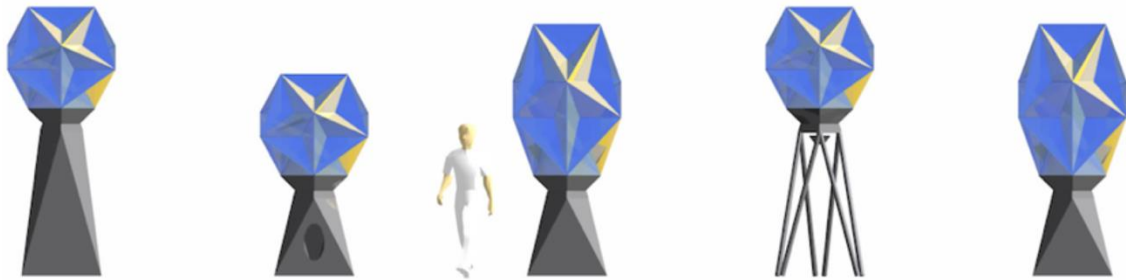

## B U D G E T \*

Artist's Fee	\$28,000
research	
design development	
drawings / model / construction documents	
construction/installation supervision	
Artwork Cost	
materials	33,000
fabrication	28,000
shipment	4,000
Consultants	
assistants	12,000
engineering	4,000
Miscellaneous Costs	
studio expenses	8,000
insurance	4,000
travel	6,000
documentation	3,000
contingency	10,000
Installation	35,000

**TOTAL PROJECT BUDGET:**

-----  
**\$175,000**

- Programmable lighting not included



20. Seth Palmiter / Motivated Metal  
Rockport, ME  
Total Cost: \$200,000

**LETTER, Denton Fire Station #6 Public Art Opportunity**

As a public artist for over twenty years, I have a wealth of capital project experience developing site-relevant public art for civic entities. I have a strong command of the skills, industry-relevant protocols, and criteria that result in beautiful, durable, dynamic public art. I am based in Mid-Coast Maine and my public art can be found in all corners of the country, California, and Alaska. I am adept at the design, fabrication, transport, and installation of significant public works. As both designer and fabricator, I am able to deliver art that is more than the sum of its part. My ability to innovate process and employ sophisticated construction techniques allows me to create monumental work within an economy of construction. I bring practical, industry-standard solutions within the envelope of lyrical, beautiful art.

My public art practice is a confluence of design, vision, materials, and mission that encourage discussion and elevate the public realm. I have experience incorporating representational theme, signage, wayfinding elements, seating, and lighting in my public art and will work with you to include any of these nuanced solutions to the Fire Station #6 Opportunity. My portfolio underscores the scope of my versatility. I am nimble mixing and matching process, material, and styles to achieve signature, targeted public art; every project is curated to suit its' site and regional cultural narrative. Though I have a wide array of compositions, the unifying attributes in my art are: Museum-caliber craftsmanship; innovative fabrication; durable, beautiful materials; and lyrical, dynamic, implied motion. My commissions nest harmoniously in their site, serve as visual stepping stones, and interact/respond to natural light; these interactive qualities endow the art to function as a living canvas, inspiring by day, night, and from season to season. The confluence of forms, ever-changing optics, and precise geometries imbue every Palmiter sculpture with universal appeal to a diverse audience. These attributes are a fit to achieve your art goals.

I design with an eye towards the "in between"; that is, not only the art, but the negative spaces created by the art, add nuance to my commissions. I seek to create sculpture that is beautiful from any angle, in harmony with the surrounding landscape, and regionally relevant to celebrate local community. Given your targeted criteria, I am interested develop one signature sculpture that is uplifting and has an interactive light element when Firefighters are called upon; additionally, I can reserve budget to include a more representational wall art feature along the Station facade you identified for possible art. The Art Suite I develop will honor the dedication of Denton Firefighters and Safety Workers, provide an uplifting landmark for the City, and serve as a welcoming feature for residents and visitors. This signature Art Suite will provide critical way-finding, punctuate the processional experience, and serve as a memorable Station ambassador. I am qualified and interested to collaborate with Stakeholders to refine this concept; together we will set an uplifting tenor that celebrates public safety workers, your history, heritage, and the livability of Denton.

The materials I use are stainless steel, bronze, stone, glass, formed metals, acrylics, etched glass, and marine grade paint. These materials remain beautiful under the rigors of harsh UV exposure, wind, rain, freeze/thaw, and pollution; these are responsible material choices which resistant vandalism. I have experience in the modalities of architecture, engineering, construction, rigging, and other technical systems which enable me to analyze and execute rigorous design solutions while transitioning between technical and artistic disciplines.

The public art I create is akin to a cultural bridge bringing people together through a shared aesthetic experience. Sculptors view their world as a canvas. We seek out ever larger expanses to enliven; humanity benefits from these art experiences. It is a privilege that my life's work allows me to enhance civic spaces for many; whether developing work for a university, a hospital, a transit facility, or a City, I am honored to participate in this endeavor. I appreciate your review and thank you for participating in the public art process.

**SETH PALMITER** 691 Rockland Street, Rockport, ME 04856 207-706-4140 Seth.Palmiter@gmail.com

# SETH EMERSON PALMITER



## PRELIMINARY PROPOSAL FIRE STATION #6, DENTON, TX

\*\*PLEASE NOTE - THIS SUBMISSION IS MY INITIAL CONCEPT. COMPOSITION, PALETTE, SCALE, ETC. CAN BE REFINED IN CONSULTATION WITH THE DENTON TEAM.\*\*

MATERIALS & OPTIC PROPERTIES - ALL MATERIALS, LIGHTING, PALETTE, ETC. TO BE REFINED IN COLLABORATION WITH THE DENTON TEAM.



Integrated Lights

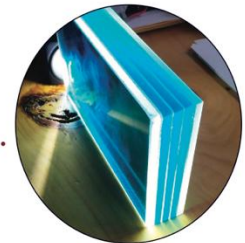

Cast Glass



Galvanized Steel

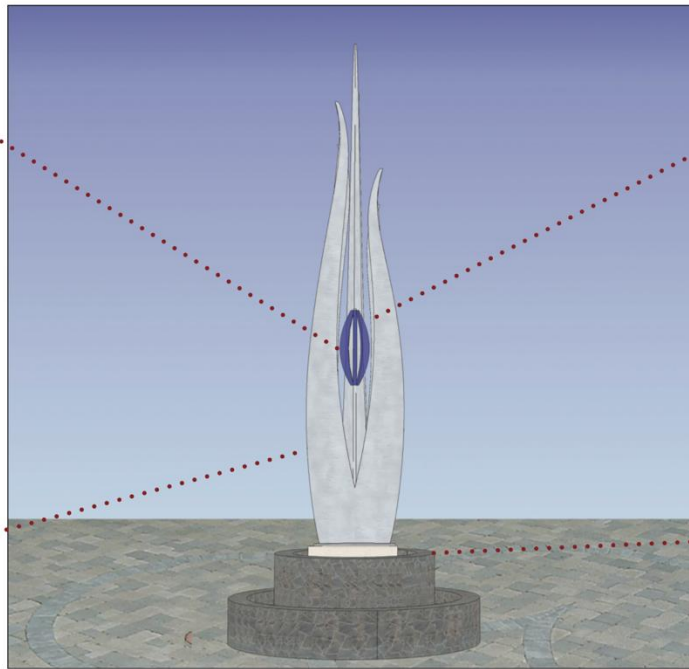

Living Planter

DIMENSIONS & SITING - Sculpture in Placeholder Site. SITING, SCALE & SIGNAGE TO BE REFINED IN COLLABORATION WITH THE DENTON TEAM.

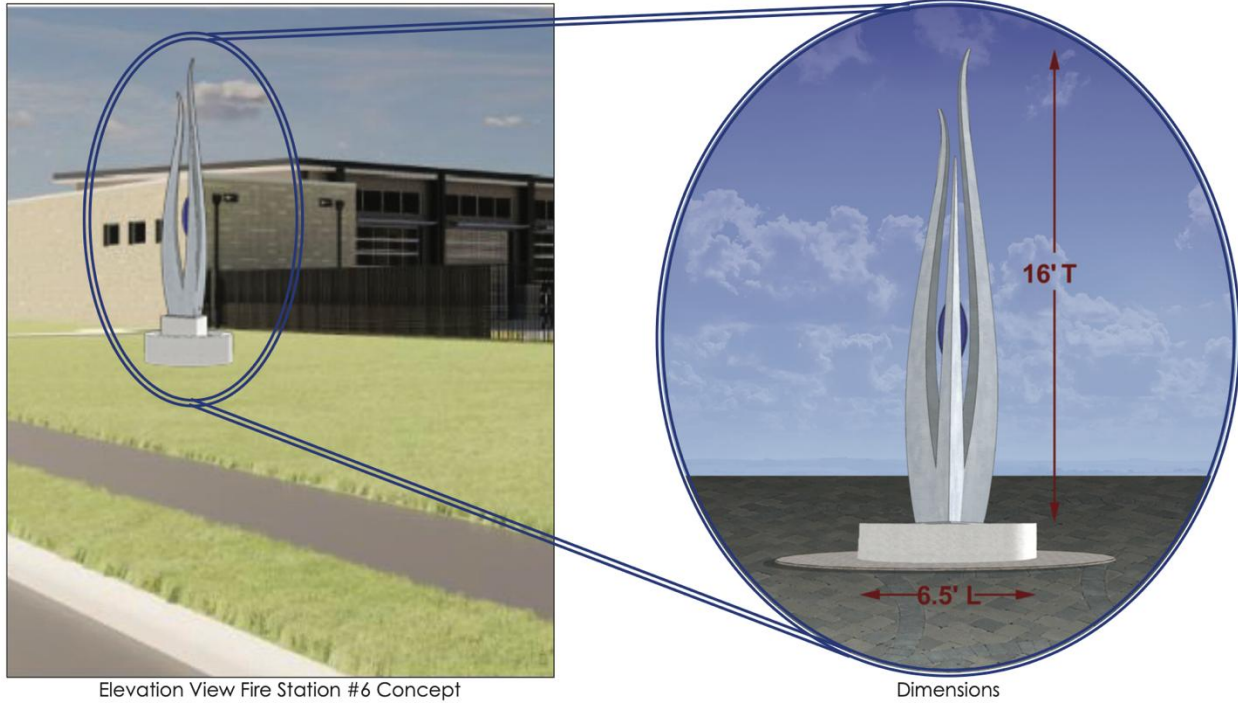

Elevation View Fire Station #6 Concept

Dimensions

360° VIEWS - Fire Station #6 Concept



## BUDGET, Denton Fire Station #6 Public Art Opportunity



Artist fee	\$ 10,000
Administration	\$ 3,500
Plate Steel	\$ 25,000
Glass/Finishes	\$ 8,500
Fabrication	\$ 85,000
Wall Sculpture	\$ 30,000
Travel	\$ 3,500
Art transport	\$ 2,000
Engineering	\$ 1,500
Modeling	\$ 2,500
Pedestal	\$ 5,500
Lighting	\$ 3,000
Installation	\$ 4,000
Contingency	\$ 16,000
<b>TOTAL</b>	<u>\$ 200,000</u>

\*\* PLEASE NOTE, THE ABOVE BUDGETS ARE ESTIMATED BALLPARK PRICES. IF SELECTED TO REFINER THIS SITE-RELEVANT PROPOSAL I WILL DESIGN THE ART PER YOUR AESTHETIC AND BUDGETARY PARAMETERS.



21. Sijia Chen Studio  
Los Angeles, CA  
Total Cost: \$190,000

## SIJIA CHEN

[www.sijiachen.com](http://www.sijiachen.com) | Instagram: [@sijiachenart](https://www.instagram.com/sijiachenart)

To Whom It May Concern,

As a multi-disciplinary artist, I utilize form, scale, and light to explore the intersection of personal identity, cultural convergence, and self-determination. My works contemplate the complexity of shared heritage and regional culture, and how those influences shape our individual aspirations and community dynamics. Central to my practice is a social engagement process with a strong emphasis on inclusion and representation. I collaborate with communities to create artworks that reflect both personal narratives and collective experiences—producing site-specific installations that serve as dynamic, multicultural labyrinths containing layers of context and detail.

My public works are studies of the perpetual duality of our natural state, they are representations of the friction and equilibrium between individuality and community, creativity and tradition, aspiration and humility. My process involves reconstructing natural objects, landscapes, and architectural elements, and infusing them with public-sourced materials and information, visual narratives, abstract elements, and figurative images.

I have extensive experience collaborating with city agencies, landscape architects, general contractors, engineers, and fabricators to deliver projects from concept to installation. My public artworks have been commissioned to serve as gateway markers, placemaking, functional seating and play elements, and points of cultural resonance. My works including *SWA*, *Bloom*, *Blossom*, *Endeavor*, *Cloud Field*, and *New Dawn* demonstrate my ability to design and deliver large-scale, dynamic, and durable installations that are responsive to context and grounded in community dialogue.

My intent is to create a site-specific work that fulfills the project's mission, activates Fire Station #6 with a dynamic and immersive three dimensional work, and reflects the cultural heritage and themes representative of City of Denton. My concept for your project would also incorporate papercut art inspired perforations, which is recurring motif in my works. Public engagement will be essential in developing and finalizing elements of the final design of the perforations. As I have done for my completed public works *SWA*, *Bloom*, *Blossom*, *Endeavor*, *Cloud Field*, and *New Dawn*, I would organize a holistic program of community events, townhall style meetings, and papercut workshops. A key component of the workshops will be to solicit from the community their responses to a curated list of questions related to the project's theme, which I will then translate visually into figurative images and patterns through the perforations. Additionally, participants will have the opportunity to create their own papercut designs during the workshops, so that they can potentially be incorporated into the final design of the artwork. A designated website would serve as a platform for the public to submit their ideas and designs throughout the community engagement phase. This direct community participation and contribution to the development of the artwork ensures it is representative and site-specific. The project becomes more than an artistic composition, it is a collection of personal and communal ideas, narratives, and memories, and is the culmination of a community movement.

I welcome and hope for the opportunity to present and expand further on my concept for your project, thank you for your time and consideration.

Sincerely,



Sijia Chen



# Inspiration

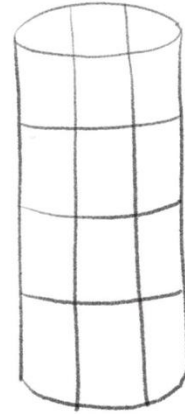

5

# LIFE TOWER CONCEPT RENDERING











## PROJECT BUDGET

Description	Amount
Design & Fabrication Labor	\$70,000
Materials	\$30,000
Shipping & Installation	\$10,000
Engineering Review & Site Plan	\$10,000
Site Construction	\$30,000
Travel, Insurance, Administrative Costs	\$5,000
Artist Fee	\$25,000
Contingency	\$10,000
<b>Total</b>	<b>\$190,000</b>

22. Sonarta LLC / Shahla Rahimi Reynolds & Cyrus Reynolds  
Reseda, CA  
Total Cost: \$181,000

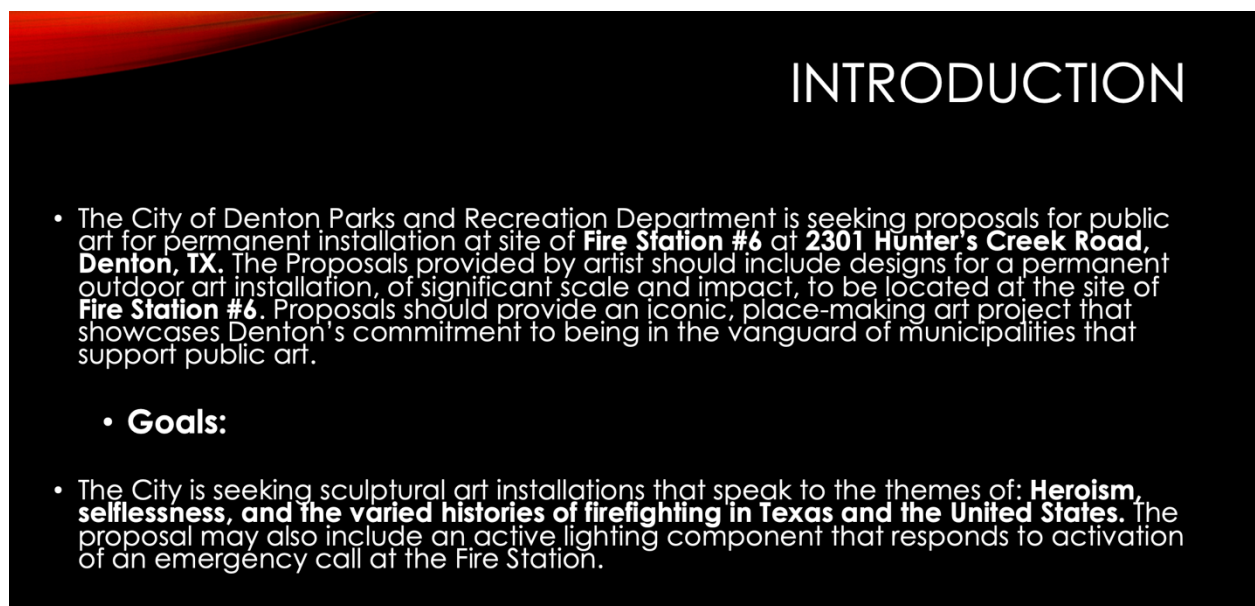

# CONCEPT NARRATIVE/ARTIST STATEMENT

- As the alarm rings, another day on the job begins. To anyone else the alarm would be a cause for panic, but to a firefighter it is a signal to go forth and serve the people they've sworn to protect. Springing into action to save lives, property, and the community they serve are all key aspects that define a firefighter's training.
- For a firefighter, being ready when a call comes in is an immensely important part of the job. Every part of the uniform, from the helmet all the way down to the boots, needs to be properly equipped and secured at a moment's notice often throughout a regular shift.
- This sculpture highlights that key part of a firefighter's routine. The figure exemplifies a focused and trained energy, showcasing their experience and how much the process has become second nature to them. Much like how the average person prepares to go to work, so too must a firefighter prepare themselves for the challenges and risks that come with serving and helping the public on the many calls they respond to.

**PLEASE NOTE: CONCEPT MAQUETTE'S COLOR DOES NOT REPRESENT FINAL BRONZE SCULPTURE**

## WHEN SERVICE CALLS

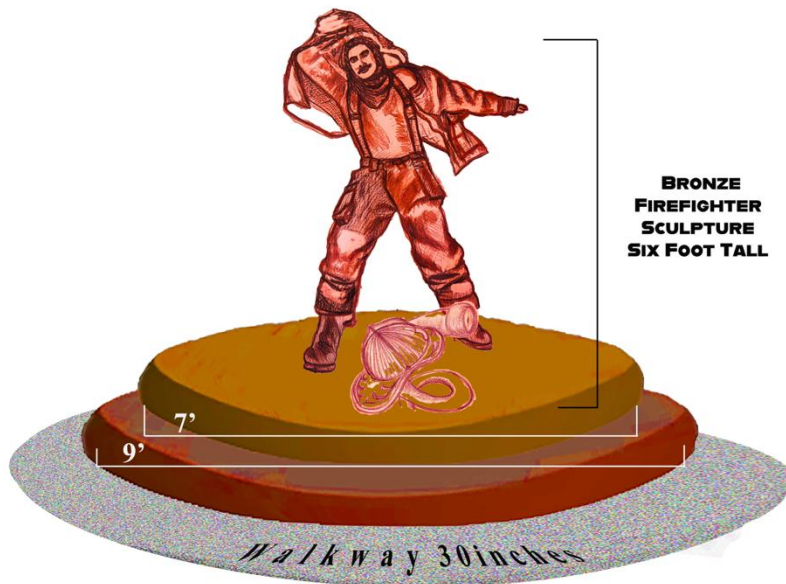

# CONCEPT DRAWING

**Sonarta LLC Studio Fire Station 6, Public Art  
Project Proposed Budget**

**Artist Design Fee**

Preliminary Design	\$ 32,000
Design Development	
Shop Drawings and Contract Documents	\$ 3,000

**Professional Consultation Fees**

Professional Engineer licensed in the State of Texas Architect	\$ 5,000
Fire Export Consultant Fee	\$ 5,000

**Administrative Expenses**

Travel	\$ 8,500
Studio expenses	\$ 3,500

**Photography and Documentation**

Copyright registration fee	\$ 8,000
Photography of work in progress	

**Casting and Transportation Costs**

Total cost for sculpture casted and delivered	\$ 65,000
---	-----------

**Installation**

Labor, Equipment, Traffic barriers, City permits, etc.	\$ 4,000
Base, Landscaping, Removal, Electrical modifications	\$ 23,000

**Insurance**

Artwork, General Liability, Texas Worker's Compensation Automotive Liability Transportation Coverage	\$ 1,000
---	----------

Contingency	\$ 23,000
-------------	-----------

TOTAL	\$181,000
-------	-----------



23. Mirek Struzik  
Wrocław, Poland  
Total Cost: \$200,000

## Artist Statement

I have previously completed successful projects in the public realm, ranging from public parks, through botanic gardens, to large shopping malls. I am especially fascinated by the floral patterns, such as constructions of flowers and plants and the topic of transplanting floral motifs from micro to macro scale.

The defining aspect of my art is its ability to transform itself at dusk and present the nature transposed from a micro to macro scale through use of biomimicry. My series of sculptures created for parks and gardens were also based on naturalistic design principles and were designed to amplify the effects of natural light.

When the sun sets, the dynamic illumination systems built in my sculptures let them undergo a complete metamorphosis, completely changing their character. It's a great feature in dynamic public places, where a lot of people walk. As my Bubble Forest in Nice, France proved, my art also serves as perfect landmarks that make navigation in the area easier. It also works interactively, as an attractive selfie spot.

In my past projects, I have successfully collaborated with managers and general constructors of large buildings, consulting professionals and several fabricators. Some projects I have done include coordinating with civic professionals on the municipal level. My artworks are engaging pieces that carefully fit, without necessarily seeming so, into their spaces by using a creative logic.

I usually hire local companies to prepare concrete foundations and electric infrastructure for my sculptures.

Most importantly, I believe that it is key for public art projects to create meeting spots, gathering places. I always design my sculptures to be attractive selfie spots and recognizable landmarks, so they serve a very practical purpose of defining the space around them and building a sense of ownership in the community. This way, they become local attractions and are used by the people in everyday life and conversations. "Let's meet at the Bubble Forest" or "Let's meet at the Dandelions" are phrases commonly used in Nice, France or Kirkland, Wa.

Best regards,  
Mirek Struzik

# Proposed Design

## *The Timeless Firefighter*

A sculpture proposal by Mirek Struzik

For the Fire Station #6 project in Denton, I'd like to propose the *Timeless Firefighter* - a sculpture that depicts heroism incarnated: St. Florian, the saint patron of firefighters. This inspiration dates back to the 3<sup>rd</sup> century AD and is universally associated with heroism, courage, loyalty and selflessness. Above him arcs a dynamic stream of water, symbolizing his legendary ability to save whole towns from fire with just a single jug of water. He's a legendary ideal, so it seems a good fit as both a spiritual guardian for those who serve and a memorial of those who sacrificed their lives saving others.

In the evening the sculpture would be uplit and the shadows cast on the wall by the arc would symbolize dangerous elements against which he protects us.

### **Materials**

Synthetic stone, electropolished stainless steel, lamps

### **Detailed budget breakdown**

The budget includes: design, fabrication, delivery to port chosen by the Client, installation on site

The budget does not include: transport from port to the installation site, preparing the foundation with secured power line for lamps and slots for the lamps, paving the area under the sculpture (as shown in design visualizations)

Materials:	\$20 000,00
Engineering:	\$5 000,00
Artist fee:	\$40 000,00
Fabrication:	\$120 000,00
Deliver to port:	\$7 000,00
Installation:	\$8 000,00
Total budget:	\$200 000,00









24. Studiofolia/James Dinh  
Cerritos, CA  
Total Cost: \$175,000

Dear Selection Committee:

It is an honor to submit my interest and preliminary design concept for the Denton Fire Station public art project. Based in Los Angeles County, I founded the collaborative design practice Studiofolia in 2014 with the simple mission of designing public art spaces that connect people to memory and place. Because the context and requirements of each project are different, my design process is based on an *approach* rather than a singular style or medium. This focus on site-specificity is reflected in the diversity of my built projects in different communities across the country. Each project tells a story that is unique to its place.

I am drawn to the Denton Fire Station public art project because I believe the selfless service of firefighters and first responders should be honored and recognized. Having completed large-scale, community-centered artworks across the country, I believe that my experience working with different stakeholders and engaging diverse communities will make me a strong candidate for this project.

#### Design Concept: Tower of Service

The tower-like shape of the proposed sculpture is inspired by fire lookout towers, which were once found in cities, but are now mostly seen in wilderness areas. Like the lookout towers, the artwork is intended to be a beacon for the community that recognizes and celebrates the work of fire fighters.

Made of steel panels, the sculpture stands about 16 feet tall and 4 feet wide. Each of the sculpture's four sides contains four medallions of the St. Florian Cross, which is an ancient symbol that represents fire fighting departments around the world. Each side also contains cut-out text of a "core value" of the Denton Fire Department: respect, integrity, courage, and humility.

In the center of each medallion are images of things that are associated with fire fighting, such as axes, hoses, hydrants, extinguishers, etc. The artist will work with the fire station staff to determine the fire-fighting objects that are represented in each circular medallion.

One in-ground LED light can be placed in the middle of the base of the sculpture. Normally lit a red color at night, the light can change to blue when fire fighters respond to emergencies. The sculpture is envisioned to be painted the same iconic red color as fire trucks. A highly durable industrial paint such as Tnemec or Carboline Carbothane can be used.

The design shown in this proposal is intended to be preliminary and conceptual. The artist anticipates that the design will be enriched and evolve with continual feedback from stakeholders. The artist will work with the first station staff and the city to determine the most visible and appropriate location for the sculpture. Thank you for your consideration

Sincerely,

James Dinh  
Studiofolia





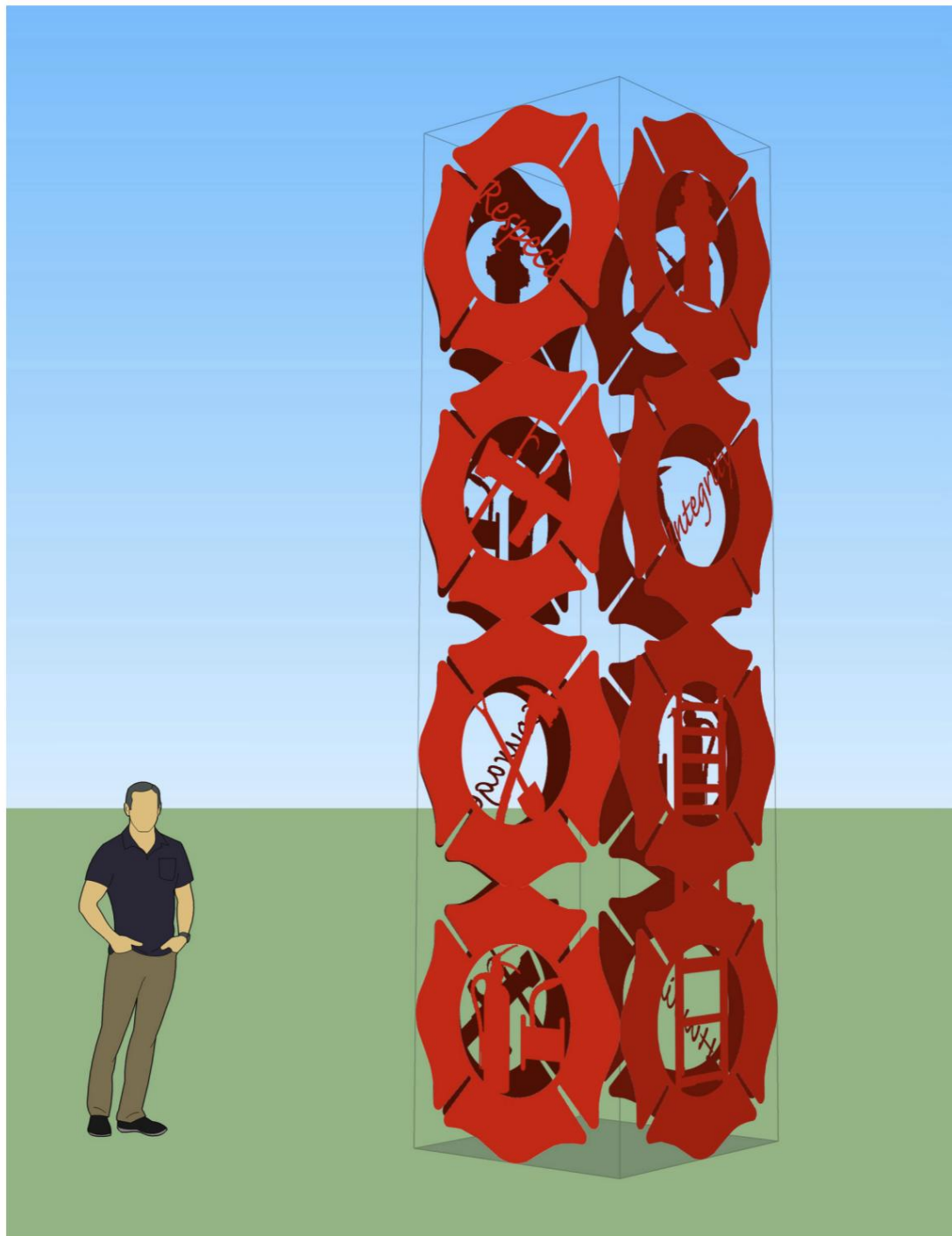



Elevation view of each side of the proposed sculpture. The artist will work with the fire station staff to determine the fire-fighting objects that are represented in each circular medallion.





---

**Budget Estimate**

Item	Cost
<b>DESIGN</b>	
Artist fee (~12.5%)	22,000
Computer modeling / drawings	6,000
Structural engineer	6,000
Travel	6,000
<b>OFF-SITE WORK</b>	
Sculpture materials & fabrication	75,000
Shipping	6,000
<b>ON-SITE WORK</b>	
Concrete footing	20,000
Installation	10,000
Lighting (1 in-ground LED fixture)	6,000
<b>CONTINGENCY (~10%)</b>	<b>18,000</b>
<b>TOTAL</b>	<b>175,000</b>

Note: Budget does not include site prep  
or electrical service conduits to the artwork



25. SV Randall Studio LLC  
Dallas, TX  
Total Cost: \$190,000

SV Randall

3/20/20

# City of Denton Parks and Recreation Department FIRE STATION # 6

 PRELIMINARY DESIGN PROPOSAL

#6 RFP-8774

City of Denton - Fire Station # 6

#6 RFP-8774

## DESIGN GOALS

My aim for this project is to create engaging and beautiful piece of sculptural artwork that will captivate the interest of the City of Denton residents for the long-term. This sculpture was designed with 3 primary goals in mind:

**Honor and Inspire:** To celebrate the heroism of firefighting in Texas and the United States, recognizing not only the bravery and sacrifice of firefighters but also the deep sense of community, resilience, and service they embody. The sculpture seeks to stand as a lasting tribute, inspiring pride and gratitude in all who encounter it.

**Dynamic Perspective:** The sculpture is designed to be interesting from all angles, allowing for maximum enjoyment to residents, whether they are walking or driving by.

**Stylized Representation:** The sculptures exist in a playful space between abstraction and representation in order to evoke rather than directly depict.

Design 2A - "Bravery Endures"

Rendered here at 12 x 20 feet



Design 2B - "Bravery Endures"

Rendered here at 12 x 20 feet



Design 2B - "Bravery Endures"

Rendered here at 12 x 20 feet



City of Denton - Fire Station # 6

#6 RFP-8774

Design 2D - "Bravery Endures"

Rendered here at 12 x 20 feet



## Tentative Budget Overview

Turn Key Engineering, Fabrication, Transportation, Foundation and Installation - Decotron (Dallas, TX)

<b>Structural Engineering, Fabrication, Transportation</b> - Materials, CNC cutting services, labor, transport, rigging	\$107,000
<b>Foundation + Installation</b> Site prep (excavation and grading if needed) and concrete footing	\$26,000
<b>Permits and Insurance</b> - Liability insurance, permitting, & city fees	\$4,000
<b>Artist Fee</b> (16%) - Concept design, artist labor, documentation, studio admin. and overhead	\$34,000
<b>Contingency</b> (10%) - Unexpected expenses	\$19,000
<b>TOTAL:</b>	<b>\$190,000</b>

***Pricing quotes from subcontractors are initial estimates at the maximum cost.***  
*The bottom line can be lowered depending on scale of sculpture to be determined after consulting with City of Denton Public Art Committee.*



26. The Red Pine Company / Elizabeth Akamatsu  
Nacogdoches, TX  
Total Cost: \$200,000

**DENTON FIRE STATION #6**

**THE ESSENCE OF LIFE**

Firefighters and water are two essential elements to life and a healthy community.

Water is a crucial resource and primary firefighting agent for firefighters, serving as both a life-saving tool and a potential hazard. It's used to extinguish fires by cooling flammable materials and creating steam that smothers the flames.

This single water drop of water symbolizes the importance of water. Water is the essence of life.

Towering at 12 feet tall with dimensions of 6.5 feet by 6.5 feet, this droplet will symbolize the importance of water. Resting upon a 12- to 24-inch tall concrete base, the sculpture will blend seamlessly into its surroundings, with its final height dictated by the landscape design. The surface may be brushed stainless steel for a sleek, reflective effect or powder-coated in a vibrant hue to further express the warmth and passion firefighters pour into their work. If electricity is available, this tribute can become even more dynamic. Lights embedded within the sculpture could flicker when an emergency call is made—serving as a visible reminder that somewhere, firefighters are rushing toward danger on behalf of others. As the sun sets, internal lighting would illuminate the heart, allowing its presence to shine through the night as a beacon of resilience, heroism, and love for the community. This project isn't just about a structure—it's about capturing the spirit of those who serve, ensuring their sacrifices are forever seen, felt, and honored. Words reflecting those of a firefighter's character will be laser cut out of the metal. These words can be changed to those desired by the committee. The sculpture will be bolted to the concrete base using concrete anchor bolts.

**THESE WORDS WILL BE LASER CUT OUT OF 3/8" STAINLESS STEEL**

Firefighters charge into danger when others flee, risking everything to save lives.

Courage is not the absence of fear, but the will to act despite it.

Every alarm signals a call to serve, protect, and sacrifice for others.

A firefighter's duty is not just to fight flames, but to safeguard hope.

Strength is measured not in muscle, but in the willingness to face the unknown.

Firefighters stand between chaos and safety, answering the call without hesitation.

The firehouse is more than a workplace—it's a brotherhood built on trust and bravery.

When disaster strikes, firefighters rise, proving that heroism is a choice, not a title.

The greatest reward for a firefighter is a life saved, not recognition earned.

Firefighters don't seek glory; FIREFIGHTERS seek to make a difference in someone's darkest hour.

Every fire fought is a battle won for the community they vow to protect.

The firefighter's creed is simple: serve with honor, act with courage, and never back down.

Firefighters risk everything to protect strangers, proving heroism is a choice.

In the face of disaster, firefighters stand as the last line of hope.

Every rescue is a testament to courage, selflessness, and unwavering determination.

Firefighters don't just fight flames—they fight for lives, communities, and safety.





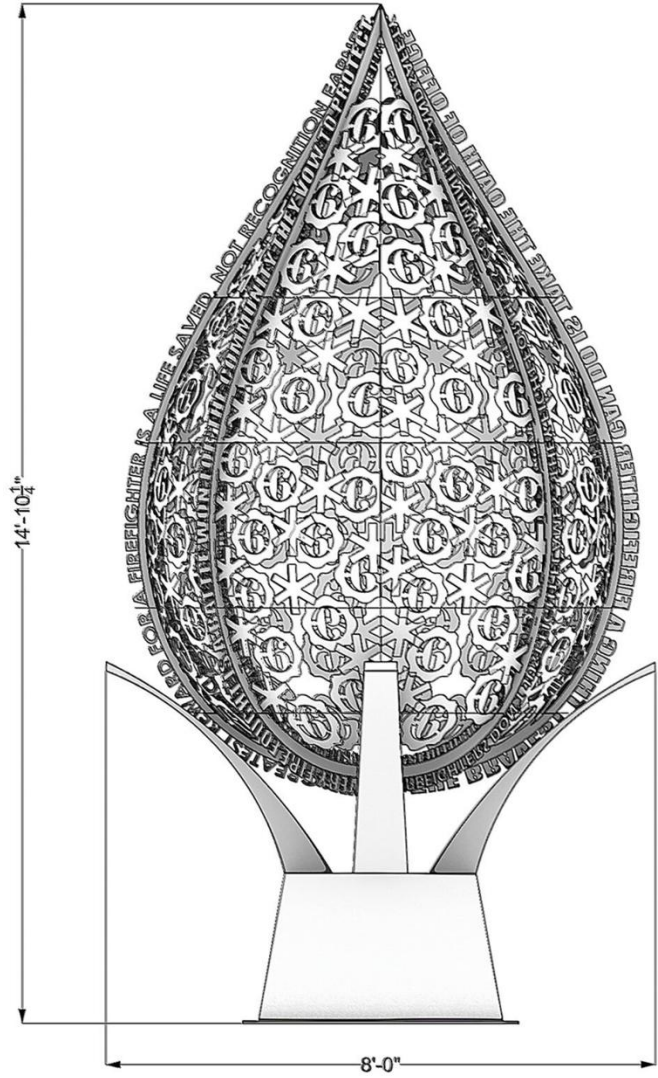
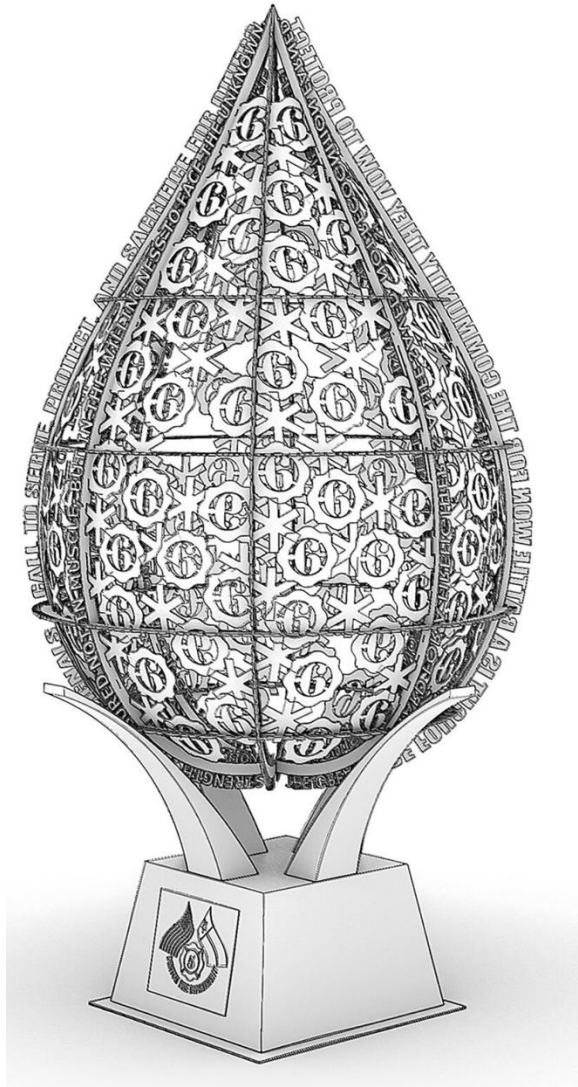

27. UrbanRock Design LLC  
Los Angeles, CA  
Total Cost: \$140,400

### ***All Down the Line***

Drawing from the life and equipment of firefighters, this piece takes inspiration from actions of the work itself. ***All Down the Line*** presents a vision of common purpose and attention to the detail of the work.

The organizing gesture of the piece is a winding fire hose- a flowing organizing line that moves through space and captures three images within its contours. Like a line moving through space, it creates a dynamic presence that is like a three-dimensional drawing.

Everyday moments found within the life of firefighters are highlighted- equipment within the cubbies of a fire truck, jackets and helmets within the station, a close-up view of hands working a fire hose. These framed views capture the beauty and ethos of this work. The tools, equipment and garb are at once elegant and bold. They portray the precision and finesse demanded of this service, and the collective nature of being a firefighter.

This piece is striking from afar, perhaps a bit mysterious. Upon closer inspection, the images offer another aesthetic experience. We wish for this piece to inspire reflection and admiration for the firefighters and their work.

#### **Materials and Dimension**

The area of the piece is about 30'-0" long by 5'-0" deep by 6'-0" high. The hose element is a 3" diameter (ID) aluminum pipe (3 1/2" OD). Each of three aluminum image discs are 1/2" thick with three different diameters (3'-0", 3'-6", and 4'-0"). The discs are to be water-jet cut with solids and voids creating the image. All of the elements are to be powder-coated. The artwork has a four-color palette. To visually separate the sculpture from the foundations, there are four 1'-0" high x 2 1/2" square tubes welded to the sculpture and mortise set in and welded to a base plate. Four engineered concrete point foundations will hold the sculpture. The connection of the four base plates to those foundations will each have four stainless steel threaded rods epoxy-set anchor tie-downs with high security nuts, 16 anchors in total.



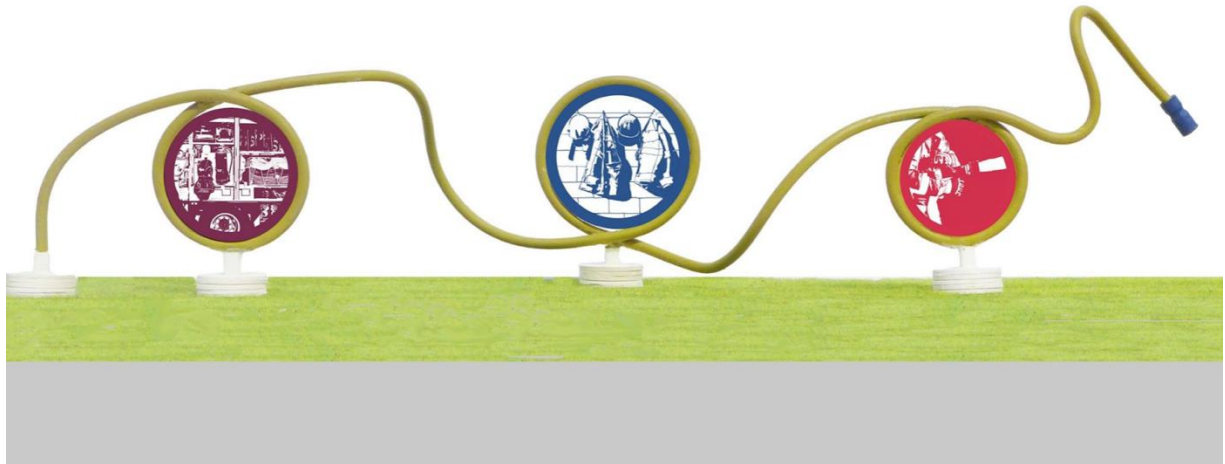



ITEM	AMOUNT
<b><u>Commission</u></b>	<b>\$110,900</b>
<b>Professional Fees</b>	
Artist Fee (18%)	\$18,900
Structural Engineer	\$5,000
<b>Fabrication and Material Costs</b>	
1/2" thick aluminum plate (for image discs & base plates)	\$10,000
3"Ø aluminum tube – (3) 20 ft pieces	\$8,000
4" aluminum tube – 2 ft piece (nozzle detail)	\$500
2 1/2" sq aluminum tube- (1) 4 ft piece (foundation standoff)	\$1,000
Waterjet Cutting (discs)	\$9,000
Rolling tube	\$10,000
Welding + Assembly	\$35,000
Powder-coating (4 colors + anti-graffiti top-coat)	\$10,000
Miscellaneous Hardware- security nuts & threaded rods	\$1,000
Shipping (between shops)	\$1,000
<b>Shipping</b>	
Crating and packing for Shipment	\$2,000
Shipping to Denton, TX	\$4,000
<b>Artist Site Visit</b>	<b>\$1,500</b>
<b>Lighting</b>	<b>\$4,000</b>
2 up-lights installed	
<b><u>Installation</u></b>	<b>\$13,000</b>
Equipment Rental (extended fork-lift)	\$6,000
Installation Labor	\$5,000
Travel & Lodging (for installation)	\$2,000
<b><u>Photography</u></b>	<b>\$1,500</b>
<b><u>Contingency</u></b>	<b>\$5,000</b>
<b>TOTAL</b>	<b>\$140,400</b>



# City of Denton

City Hall  
215 E. McKinney Street  
Denton, Texas  
www.cityofdenton.com

---

## AGENDA INFORMATION SHEET

**DEPARTMENT:** Parks and Recreation

**ACM:** Christine Taylor, Assistant City Manager

**DATE:** February 5, 2026

### **SUBJECT**

Receive a report, hold a discussion, and give staff direction regarding the Public Art Committee meeting schedule for 2026

### **BACKGROUND**

Ordinance 19-2865 (**Exhibit 2**) was adopted by City Council on January 28, 2020 and amended Section 2-29(h) of the Denton City Code to require Boards, Commissions, and Committees adopt a regular meeting schedule each year.

The requirement can be found in Section 2-29(h)(4)(c) and reads as follows:

*Unless otherwise provided by law, each board, commission, or committee, shall adopt a regular meeting schedule by no later than the body's first meeting of the calendar year. All regular meeting schedules shall be sent to the City Secretary's Office for official record keeping purposes upon adoption. Regular meeting schedules should include all planned meetings the body intends to have during the calendar year.*

The amendment was effective immediately upon its adoption. Therefore, the Public Art Committee needs to proceed with adopting its meeting schedule for 2026. In order that the meeting schedule fully reflect meetings for 2026, the proposed schedule includes those meetings held to date (**Exhibit 3**).

Because it is understood that the start time and meeting location can vary based on room availability, that information is not included as part of the proposed schedule. The requirement for an annual schedule was to clearly define the day/month. If at any point in time a meeting cannot/will not be held, a cancellation notice will be duly posted in coordination with the City Secretary's Office. There will be no need to amend the meeting schedule should a meeting have to be cancelled.

### **EXHIBITS**

Exhibit 1- Agenda Information Sheet

Exhibit 2- Ordinance 19-2865

Exhibit 3- 2026 Meeting Schedule

Respectfully submitted:  
Allison Wing, Interim Director,  
Parks and Recreation

Prepared by:  
Omar Siddiqi, Admin. Analyst,  
Parks and Recreation



ORDINANCE NO. 19-2865

AN ORDINANCE OF THE CITY OF DENTON AMENDING THE CITY OF DENTON CODE OF ORDINANCES (CODE) SECTION 2-29 (CITY COUNCIL RULES OF PROCEDURE) SUBSECTION (H) (CREATION OF COMMITTEES, BOARDS, AND COMMISSIONS) REQUIRING BOARDS, COMMISSIONS, AND COMMITTEES TO ESTABLISH A REGULAR MEETING SCHEDULE; PROVIDING FOR A SEVERABILITY CLAUSE; AND PROVIDING FOR AN EFFECTIVE DATE.

WHEREAS, the City Council of the City of Denton creates various boards, commissions, and committees to participate in the City's governmental process, and give input on topics of community importance; and

WHEREAS, the City Council recognizes that board, commission, and committee membership is a significant time commitment for Denton residents; and

WHEREAS, the City Council desires to help members of boards, commissions, and committees better understand the time commitment and meeting schedule of their respective seat by requiring the adoption of regular meeting schedules annually; and

WHEREAS, Denton City Council meetings are conducted in accordance with the Council Rules of Procedure set forth in Section 2-29 of the Denton City Code of Ordinances; NOW THEREFORE,

THE COUNCIL OF THE CITY OF DENTON HEREBY ORDAINS:

SECTION 1. That Section 2-29 (h) of the Denton Code of Ordinances, known as the Denton City Council Rules of Procedure, is hereby amended to read as follows:

(h) *Creation of committees, boards and commissions.*

(1) *Council committees:* The council may, by resolution and as the need arises, authorize the appointment of council committees. Any committee so created shall cease to exist when abolished by resolution of the council. Council committees shall comply with the Texas Open Meetings Act.

(2) *Citizen boards, commissions, and committees:* The council may create other citizen boards, commissions, and committees to assist in the conduct of the operation of the city government with such duties as the council may specify not inconsistent with the City Charter or Code. Creation of such boards, commissions, and committees and memberships and selection of members shall be by council resolution if not otherwise specified by the City Charter or Code. Any board, commission, or committee so created shall cease to exist when abolished by a resolution approved by the council. No committee so appointed shall have powers other than advisory to the council or to the city manager, except as otherwise specified by the Charter or Code. All citizen boards, commissions, and committees shall comply with the procedural requirements of the Texas Open Meetings Act. Any reference in this article to "citizen boards, commissions,

and committees" includes citizen task forces and citizen ad hoc boards, commissions, and committees unless otherwise indicated herein.

(3) *Appointments:*

- a. Individual city council members making nominations for members to citizen boards, commissions, and committees will consider interested persons on a citywide basis.
- b. The city council will make an effort to be inclusive of all segments of the community in the board, commission, and committee appointment process. City council members will consider ethnicity, gender, socio-economic levels, and other factors to ensure a diverse representation of Denton citizens.
- c. The city council will take into consideration an individual's qualifications, willingness to serve, and application information in selecting nominations for membership to each board, commission, and committee.
- d. In an effort to ensure maximum citizen participation, city council members will continue the general practice of nominating new citizens to replace board members who have served three (3) consecutive terms on the same board per the provisions of Denton Code of Ordinances, section 2-65. This provision does not apply to citizen task forces and citizen ad hoc committees.
- e. Each city council member will be responsible for making nominations for board, committee, and commission places assigned to him or her, which shall correspond to the city council member's place. Individual city council members will make nominations to the full city council for the governing body's approval or disapproval.

(4) *Rules of procedure:*

- a. All board, commission, and committee members, including citizen board, commission, and committee members, shall comply with the provisions of article II of chapter 2 of the Code of Ordinances. All board, commission and committee members, including citizen board, commission, and committee members, shall be provided a copy of these rules of procedure and a copy of the City of Denton Handbook for Boards, Commissions and Committees, which shall govern operational procedures of all boards, commissions and committees, including citizen boards, commissions, and committees. All boards, commissions, and committees, including citizen boards, commissions and committees, shall comply with these rules as to the preparation of minutes of meetings, and such minutes shall be prepared in accordance with the policies and procedures of the city secretary.
- b. All citizen board, commission, and committee members shall comply with the procedural requirements of the V.T.C.A., Texas Government Code Chapter 551, also known as the "Texas Open Meetings Act" as they appear now or may be amended in the future. Notice of all meetings shall be posted in compliance with the Texas Open Meetings Act and minutes and records will be maintained in accordance with requirements of the city secretary's office. Each citizen board, commission, and committee member shall be provided a copy of the Texas Open Meetings Act. Penalty provisions of the Texas Open Meetings Act shall only

apply to citizen boards, commissions, and committees with rule making or quasi-judicial power, as set forth in the Texas Open Meetings Act and as interpreted by Texas Courts.

c. Unless otherwise provided by law, each board, commission, or committee, shall adopt a regular meeting schedule by no later than the body's first meeting of the calendar year. All regular meeting schedules shall be sent to the City Secretary's Office for official record keeping purposes upon adoption. Regular meeting schedules should include all planned meetings the body intends to have during the calendar year.

SECTION 2. The provisions of this Ordinance are severable, and the invalidity of any phrase, clause, or part of the Ordinance shall not affect the validity or effectiveness of the remainder of the Ordinance.

SECTION 3. This ordinance shall become effective immediately upon its passage and approval.

The motion to approve this ordinance was made by PAUL MELTZER and seconded by KEELY BRIGGS, the ordinance was passed and approved by the following vote [6 - 0]:

	<b>Aye</b>	<b>Nay</b>	<b>Abstain</b>	<b>Absent</b>
Chris Watts, Mayor:	<u>✓</u>	_____	_____	_____
Gerard Hudspeth, District 1:	<u>✓</u>	_____	_____	_____
Keely Briggs, District 2:	<u>✓</u>	_____	_____	_____
Jesse Davis, District 3:	<u>✓</u>	_____	_____	_____
John Ryan, District 4:	_____	_____	_____	<u>✓</u>

Deb Armintor, At Large Place 5: ✓ \_\_\_\_\_

Paul Meltzer, At Large Place 6: ✓ \_\_\_\_\_

PASSED AND APPROVED this the 20th day of January, 2020.

Chris Watts  
CHRIS WATTS, MAYOR

ATTEST:  
ROSA RIOS, CITY SECRETARY

BY: Rosa Rios

APPROVED AS TO LEGAL FORM:  
AARON LEAL, CITY ATTORNEY

BY: Aaron Leal





# 2026 PAC meeting schedule

First Thursday of every even-numbered month (Feb., Apr., June, Aug., Oct., Dec.)

January						
S	M	T	W	T	F	S
				1	2	3
4	5	6	7	8	9	10
11	12	13	14	15	16	17
18	19	20	21	22	23	24
25	26	27	28	29	30	31

February						
S	M	T	W	T	F	S
1	2	3	4	5	6	7
8	9	10	11	12	13	14
15	16	17	18	19	20	21
22	23	24	25	26	27	28

March						
S	M	T	W	T	F	S
1	2	3	4	5	6	7
8	9	10	11	12	13	14
15	16	17	18	19	20	21
22	23	24	25	26	27	28
29	30	31				

April						
S	M	T	W	T	F	S
			1	2	3	4
5	6	7	8	9	10	11
12	13	14	15	16	17	18
19	20	21	22	23	24	25
26	27	28	29	30		

May						
S	M	T	W	T	F	S
					1	2
3	4	5	6	7	8	9
10	11	12	13	14	15	16
17	18	19	20	21	22	23
24	25	26	27	28	29	30
31						

June						
S	M	T	W	T	F	S
	1	2	3	4	5	6
7	8	9	10	11	12	13
14	15	16	17	18	19	20
21	22	23	24	25	26	27
28	29	30				

July						
S	M	T	W	T	F	S
			1	2	3	4
5	6	7	8	9	10	11
12	13	14	15	16	17	18
19	20	21	22	23	24	25
26	27	28	29	30	31	

August						
S	M	T	W	T	F	S
						1
2	3	4	5	6	7	8
9	10	11	12	13	14	15
16	17	18	19	20	21	22
23	24	25	26	27	28	29
30	31					

September						
S	M	T	W	T	F	S
		1	2	3	4	5
6	7	8	9	10	11	12
13	14	15	16	17	18	19
20	21	22	23	24	25	26
27	28	29	30			

October						
S	M	T	W	T	F	S
				1	2	3
4	5	6	7	8	9	10
11	12	13	14	15	16	17
18	19	20	21	22	23	24
25	26	27	28	29	30	31

November						
S	M	T	W	T	F	S
1	2	3	4	5	6	7
8	9	10	11	12	13	14
15	16	17	18	19	20	21
22	23	24	25	26	27	28
29	30					

December						
S	M	T	W	T	F	S
		1	2	3	4	5
6	7	8	9	10	11	12
13	14	15	16	17	18	19
20	21	22	23	24	25	26
27	28	29	30	31		



# City of Denton

City Hall  
215 E. McKinney Street  
Denton, Texas  
www.cityofdenton.com

---

## AGENDA INFORMATION SHEET

**DEPARTMENT:** Parks and Recreation

**ACM:** Christine Taylor

**DATE:** February 5, 2026

### **SUBJECT**

Receive a report, hold a discussion, and provide input to staff regarding the status of the following Public Art Committee projects:

- 1) Current Projects
  - a) Traffic Box Wraps
  - b) Fire Stations #5 and #6
  - c) MLK Jr. Recreation Center Mural
- 2) Future Public Art Projects
  - a) Linda McNatt Animal Shelter Expansion (Bond-Funded)

### **BACKGROUND**

This item provides information about recent and upcoming arts projects and seeks feedback from the committee on those projects and plans.

### **CURRENT PROJECTS**

#### ***Traffic Box Wraps***

Our Traffic Box installers wrapped eight additional boxes in October. Staff delivered a post-inspection report that found some minor issues with the installation. These issues were remedied by the installer. Additionally, paperwork for artist payments have been submitted by staff to the City's accounts payable department. Artists were offered \$200 each as an honorarium for their work on the traffic box art.

#### ***Fire Stations #5 and Fire Station #6***

Recently, a subcommittee of Fire Department Staff and Public Art Committee members met to consider the proposals received for each Fire Station. These projects are covered in detail in a separate agenda item.

#### ***MLK Jr. Recreation Center Mural***

Parks and Recreation received a \$20,000 grant from Keep America Beautiful to support a mural installation at the Martin Luther King, Jr. Recreation Center. Parks and Recreation staff have decided to use aluminum composite panels attached directly to the Recreation Center exterior walls. These panels are particularly suitable to the MLK mural project, as they allow the mural to be painted indoors.

A committee of PAC members and Parks and Recreation staff voted on the received proposals and chose JB Moore as the winning artist. Staff are working with Moore to gather the necessary documentation to begin the contracting process. An ordinance for a contract with the artist will be brought to Council by City procurement staff.

Parks and Recreation staff spoke with Keep America Beautiful to extend the project deadline to mid-February. Staff are working with a timeline that envisions installation of the panels in early February.

## **FUTURE PROJECTS**

### ***Linda McNatt Animal Shelter Public Art***

As part of the 2023 bond program, voters approved a resolution for an expansion to the Linda McNatt Animal Shelter that included a public art component. Parks staff developed an initial project scope that envisioned an outdoor public art component. Animal Services staff indicated a preference for an indoor public art piece in the facility's foyer. Public Art Committee members offered feedback in April of 2025 indicating that they were not opposed to an indoor public art piece but emphasized that at least some component of the public art for that facility should be placed outdoors so that it is visible from the street. Staff are currently revising the project scope emphasize indoor and outdoor components.

## **RECOMMENDATION**

None.

## **ESTIMATED SCHEDULE OF PROJECTS**

It is anticipated that public art components for the two fire stations will be complete by early 2027. Public art for the Animal Services Center should be complete and installed by Summer of 2027.

## **OPERATIONAL IMPACT**

Each project will have an anticipated maintenance need. Staff are currently working on determining an inspection and asset management protocol under an updated Public Art Policy that will allow for inspections of larger artwork on an annual basis, leading to more accurate estimates of maintenance needs.

## **FISCAL INFORMATION**

### Public Art Bond Issue Timeline

FY23-24 (Animal Center)	\$317,000
FY 24-25 (Fire Stations #5 and #6)	\$506,000
FY 26-27 (Active Adult Center)	\$930,000
FY 28-29 (S. Branch Library)	\$969,000

## **EXHIBITS**

Exhibit 1- Agenda Information Sheet

Exhibit 2- Presentation

Respectfully submitted:  
Allison Wing, Interim Director  
Parks and Recreation

Prepared by:  
Omar Siddiqi, Admin. Analyst,  
Parks and Recreation

A watercolor painting by Dorothy Bertine serves as the background. It features a warm, earthy color palette of browns, tans, and muted greens. The composition is abstract, with soft, blended washes of color and delicate, sketchy lines that suggest organic forms, possibly trees or flowing water. The overall mood is serene and artistic.

# Project Update

City of Denton  
Public Art Committee Meeting

February 5, 2026

Watercolor by Dorothy Bertine



# TRAFFIC BOX WRAPS

- Eight new boxes installed in October
- Post-installation issues remedied
- Honorariums will be paid to artists (\$200)

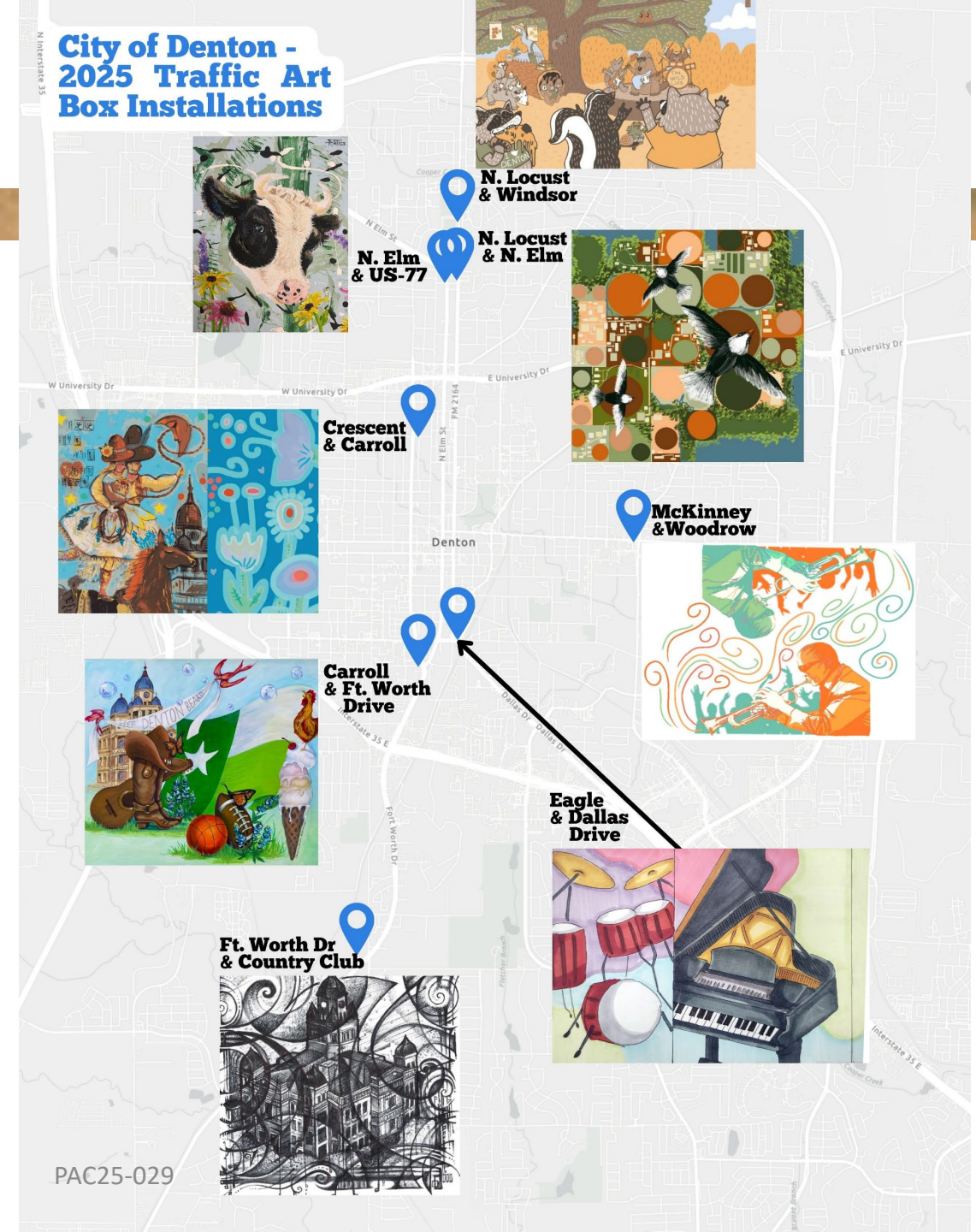

# FIRE STATION ART

- Subcommittee of Fire/PAC Ranked Proposals
- 2023 Bond-funded project
- \$253K budget for each project



Denton Maker Center,  
Fire Station #5



DiBari & Associates,  
Fire Station #6

# MLK JR. RECREATION CENTER MURAL

- Committee of PAC/Parks Staff considered and ranked received artist portfolios
- KAB \$20,000 grant
- Staff have contacted the highest-ranked artist
- The mural will be painted on aluminum panels
- Estimated installation: Early February

Supplier Scoring Summary      8938 Addendum 1 - MLK Recreation Center Mural - Scoring Round

Supplier	Rank	Score	Call for Artists	Artistic merit of previous	Artist experience delivered	Artist experience working
		100	50.00	25.00	25.00	
JD Moore Portfolios	1	93.00	48.00	24.00	21.00	
Plaibooks	2	70.00	38.00	18.00	14.00	
Gregory Beck Art Studio	3	68.00	36.00	20.00	12.00	
Marcus Williams	4	68.00	40.00	17.00	11.00	
Lucas P-Li Art	5	65.00	34.00	17.00	14.00	
Optimize Ops	6	50.00	24.00	15.00	11.00	
		69.00	36.67	18.50	13.83	



# Linda McNatt Animal Shelter Expansion

- Animal Shelter staff wanted an interior piece in the facility lobby
- PAC in April asked for an external component for the public art visible from the street
- Staff are working to write a project scope involving both elements

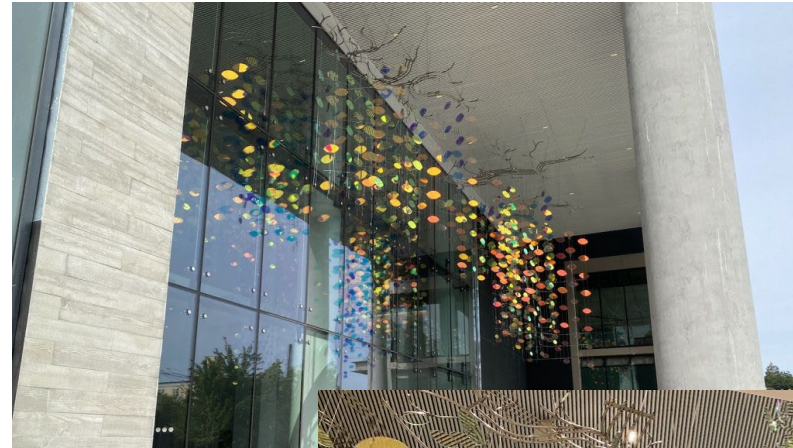

Ray King, Golden Wave

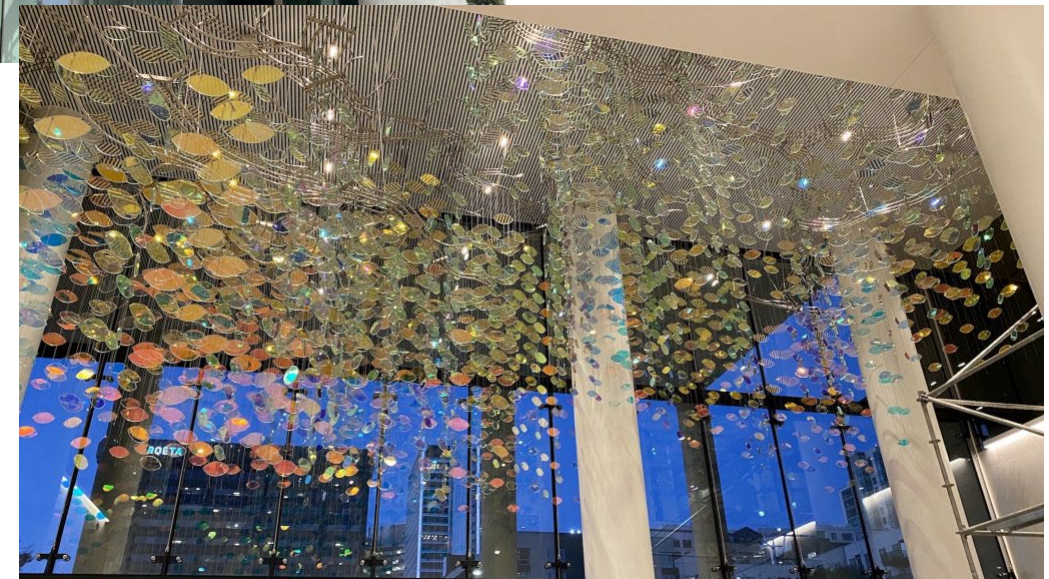





Questions?