



**S1- STONE**  
MANUFACTURE:  
EL DOMADO STONE  
COLOR:  
GLACIER



**R1- ROOF**  
MANUFACTURE:  
GAF  
COLOR:  
PEWTER GRAY



**P1- PAINT**  
MANUFACTURE:  
SHERWIN WILLIAMS  
COLOR:  
WEB GRAY  
SW 7075



**P2- PAINT**  
MANUFACTURE:  
SHERWIN WILLIAMS  
COLOR:  
PASSIVE  
SW 7064

**SIDING,  
FIBER CEMENT PANEL**

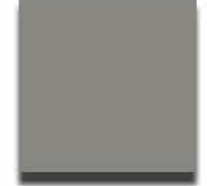

**P3- PAINT**  
MANUFACTURE:  
SHERWIN WILLIAMS  
COLOR:  
CLASSIC FRENCH GRAY  
SW 0077

**FIBER CEMENT PANEL**



**P4- PAINT**  
MANUFACTURE:  
SHERWIN WILLIAMS  
COLOR:  
EXTRA WHITE  
SW 7009

**BOARD & BATTEN  
BALCONY SIDING  
FIBER CEMENT PANEL**



**P5- PAINT**  
MANUFACTURE:  
SHERWIN WILLIAMS  
COLOR:  
IRON ORE  
SW 7069

**TRIM, FASCIA, RAILING &  
FOAM TRIM**



**M1- METAL ROOF**  
MANUFACTURE:  
REBRIDGE  
COLOR:  
CITYSCAPE

**D1- DOWNSPOUTS**  
MANUFACTURE:  
SENOK  
COLOR:  
TUXEDO GRAY

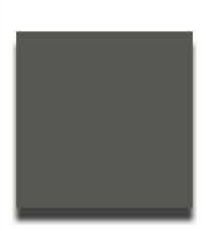

**W1- WINDOWS**  
MANUFACTURE:  
PLYGEM  
COLOR:  
WHITE



**W1- WINDOWS**  
MANUFACTURE:  
PLYGEM  
COLOR:  
WHITE

**ELEVATION LEGEND**

T.O.H. = TOP OF HEEL  
T.O.D. = TOP OF DECK  
T.O.P. = TOP OF PLATE  
T.O.F. = TOP OF FOUNDATION

**MATERIALS KEY**

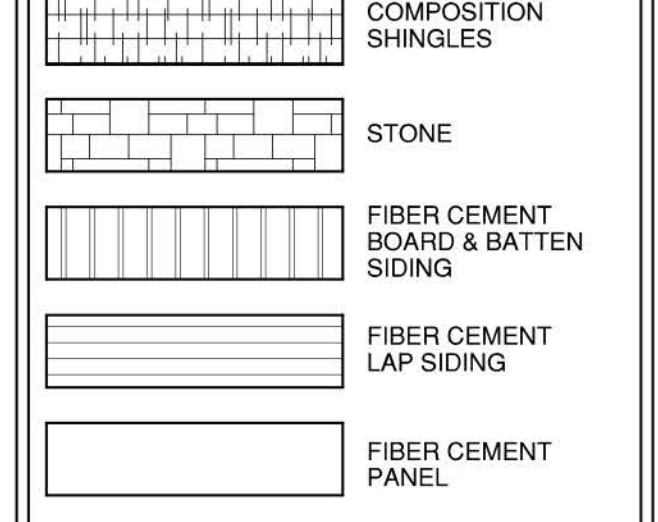

NOTE: CONTRACTOR TO VERIFY ELECTRICAL METER BOX SIZES AND COORDINATE SURROUNDING SIDING FEATURE  
NOTE: CONDENSER UNITS MOUNTED AT GROUND FLOOR LEVEL.

**BUILDING A - ELEVATION KEY**

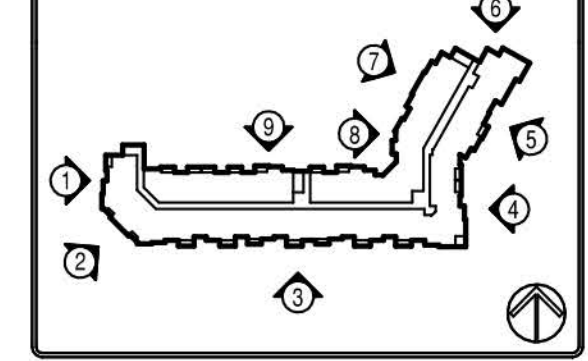

**REVISIONS**

NO.	DATE	DESCRIPTION

**STONEHAWK DENTON 380**  
DENTON, TEXAS  
**STONEHAWK CAPITAL PARTNERS, LLC**



**1 BUILDING A - FRONT ELEVATION**  
SCALE: 1' = 1/8"



**2 BUILDING A - FRONT ELEVATION**  
SCALE: 1' = 1/8"

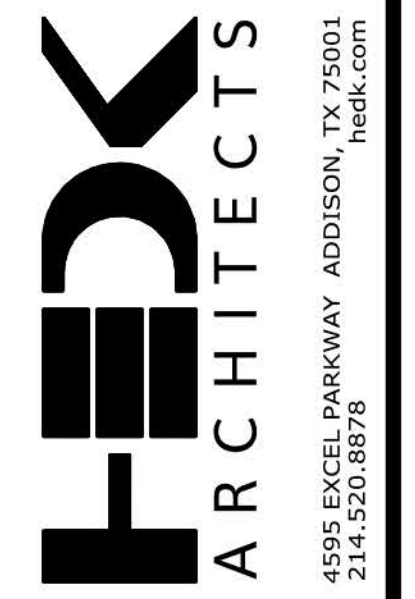

DATE  
**07-12-2023**

PROJECT  
**22119**

SHEET NUMBER

**A4-00**  
BUILDING A  
ELEVATIONS

COPYRIGHT © HECK Architects ALL RIGHTS RESERVED





**S1- STONE**  
MANUFACTURE:  
EL DORADO STONE  
COLOR:  
GLACIER



**R1- ROOF**  
MANUFACTURE:  
GAF  
COLOR:  
PEWTER GRAY



**P1- PAINT**  
MANUFACTURE:  
SHERWIN WILLIAMS  
COLOR:  
WEB GRAY  
SW 7075

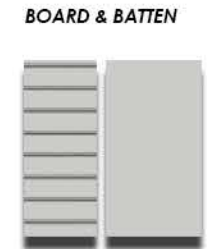

**P2- PAINT**  
MANUFACTURE:  
SHERWIN WILLIAMS  
COLOR:  
PASSIVE  
SW 7064

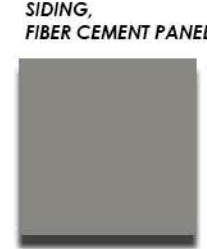

**P3- PAINT**  
MANUFACTURE:  
SHERWIN WILLIAMS  
COLOR:  
CLASSIC FRENCH GRAY  
SW 0077



**P4- PAINT**  
MANUFACTURE:  
SHERWIN WILLIAMS  
COLOR:  
EXTRA WHITE  
SW 7006

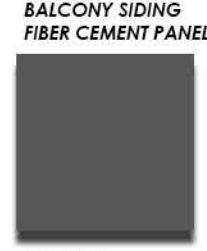

**P5- PAINT**  
MANUFACTURE:  
SHERWIN WILLIAMS  
COLOR:  
IRON ORE  
SW 7069



**M1- METAL ROOF**  
MANUFACTURE:  
REBRIDGE  
COLOR:  
CITYSCAPE



**D1- DOWNSPOUTS**  
MANUFACTURE:  
SENOK  
COLOR:  
TUXEDO GRAY



**W1- WINDOWS**  
MANUFACTURE:  
PLYGEM  
COLOR:  
WHITE

**ELEVATION KEY**

SCALE: 1' = 1/16"



**ELEVATION LEGEND**

T.O.H. = TOP OF HEEL  
T.O.D. = TOP OF DECK  
T.O.P. = TOP OF PLATE  
T.O.F. = TOP OF FOUNDATION

**MATERIALS KEY**

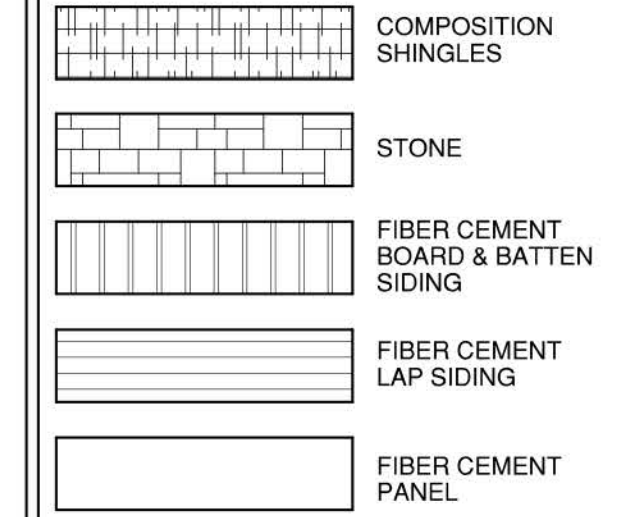

NOTE: CONTRACTOR TO VERIFY ELECTRICAL METER BOX SIZES AND COORDINATE SURROUNDING SIDING FEATURE  
NOTE: CONDENSER UNITS MOUNTED AT GROUND FLOOR LEVEL

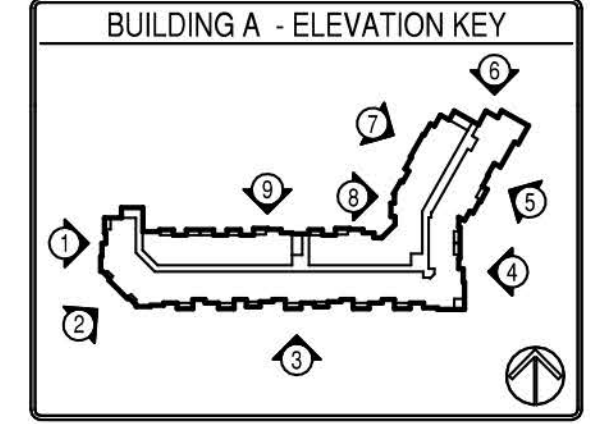

**REVISIONS**

NO.	DESCRIPTION



**3a** BUILDING A - FRONT ELEVATION - PART A  
SCALE: 1' = 1/8"



**3b** BUILDING A - FRONT ELEVATION - PART B  
SCALE: 1' = 1/8"

**STONEHAWK DENTON 380**  
DENTON, TEXAS  
**STONEHAWK CAPITAL PARTNERS, LLC**



DATE  
**07-12-2023**

PROJECT  
**22119**

SHEET NUMBER

**A4-01**  
BUILDING A  
ELEVATIONS

COPYRIGHT © HEDK Architects ALL RIGHTS RESERVED





S1- STONE  
MANUFACTURE:  
EL DOMADO STONE  
COLOR:  
GLACIER



R1- ROOF  
MANUFACTURE:  
GAF  
COLOR:  
PEWTER GRAY



P1- PAINT  
MANUFACTURE:  
SHERWIN WILLIAMS  
COLOR:  
WEB GRAY  
SW 7075



P2- PAINT  
MANUFACTURE:  
SHERWIN WILLIAMS  
COLOR:  
PASSIVE  
SW 7064



P3- PAINT  
MANUFACTURE:  
SHERWIN WILLIAMS  
COLOR:  
CLASSIC FRENCH GRAY  
SW 0077



P4- PAINT  
MANUFACTURE:  
SHERWIN WILLIAMS  
COLOR:  
EXTRA WHITE  
SW 7009  
BOARD & BATTEN  
BALCONY SIDING  
FIBER CEMENT PANEL



P5- PAINT  
MANUFACTURE:  
SHERWIN WILLIAMS  
COLOR:  
IRON ORE  
SW 7069



M1- METAL ROOF  
MANUFACTURE:  
SERENICE  
COLOR:  
CITYSCAPE



D1- DOWNSPOUTS  
MANUFACTURE:  
SENOK  
COLOR:  
TUXEDO GRAY



W1- WINDOWS  
MANUFACTURE:  
PLYGEM  
COLOR:  
WHITE

ELEVATION LEGEND	
T.O.H. =	TOP OF HEEL
T.O.D. =	TOP OF DECK
T.O.P. =	TOP OF PLATE
T.O.F. =	TOP OF FOUNDATION

MATERIALS KEY	
	COMPOSITION SHINGLES
	STONE
	FIBER CEMENT BOARD & BATTEN SIDING
	FIBER CEMENT LAP SIDING
	FIBER CEMENT PANEL

NOTE: CONTRACTOR TO VERIFY ELECTRICAL METER BOX SIZES AND COORDINATE SURROUNDING SIDING FEATURE

NOTE: CONDENSER UNITS MOUNTED AT GROUND FLOOR LEVEL.

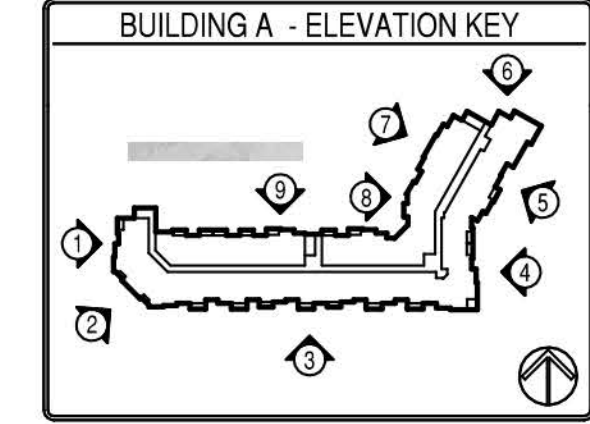

REVISIONS	



**4** BUILDING A - FRONT ELEVATION  
SCALE: 1" = 1/8"



**5** BUILDING A - FRONT ELEVATION  
SCALE: 1" = 1/8"

**STONEHAWK DENTON 380**

DENTON, TEXAS

**STONEHAWK CAPITAL PARTNERS, LLC**



DATE  
07-12-2023

PROJECT  
22119

SHEET NUMBER

**A4-02**  
BUILDING A  
ELEVATIONS

COPYRIGHT © HEDK Architects ALL RIGHTS RESERVED





**S1- STONE**  
MANUFACTURE:  
EL DOMADO STONE  
COLOR:  
GLACIER



**R1- ROOF**  
MANUFACTURE:  
GAF  
COLOR:  
PEWTER GRAY



**P1- PAINT**  
MANUFACTURE:  
SHERWIN WILLIAMS  
COLOR:  
WEB GRAY  
SW 7075



**P2- PAINT**  
MANUFACTURE:  
SHERWIN WILLIAMS  
COLOR:  
PASSIVE  
SW 7064

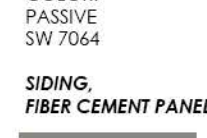

**SIDING,  
FIBER CEMENT PANEL**



**P3- PAINT**  
MANUFACTURE:  
SHERWIN WILLIAMS  
COLOR:  
CLASSIC FRENCH GRAY  
SW 0077



**P4- PAINT**  
MANUFACTURE:  
SHERWIN WILLIAMS  
COLOR:  
EXTRA WHITE  
SW 7006



**BOARD & BATTEN  
BALCONY SIDING  
FIBER CEMENT PANEL**



**P5- PAINT**  
MANUFACTURE:  
SHERWIN WILLIAMS  
COLOR:  
IRON ORE  
SW 7069

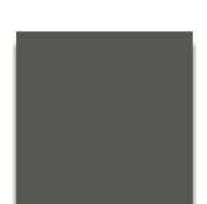

**M1- METAL ROOF**  
MANUFACTURE:  
REBRIDGE  
COLOR:  
CITYSCAPE



**D1- DOWNSPOUTS**  
MANUFACTURE:  
SENOC  
COLOR:  
TUXEDO GRAY



**W1- WINDOWS**  
MANUFACTURE:  
PLYCEM  
COLOR:  
WHITE



**6 BUILDING A - END ELEVATION**  
SCALE: 1' = 1/8"



**7 BUILDING A - REAR ELEVATION**  
SCALE: 1' = 1/8"



**8 BUILDING A - REAR ELEVATION**  
SCALE: 1' = 1/8"

**ELEVATION LEGEND**

T.O.H. = TOP OF HEEL  
T.O.D. = TOP OF DECK  
T.O.P. = TOP OF PLATE  
T.O.F. = TOP OF FOUNDATION

**MATERIALS KEY**

COMPOSITION SHINGLES  
STONE  
FIBER CEMENT BOARD & BATTEN SIDING  
FIBER CEMENT LAP SIDING  
FIBER CEMENT PANEL

NOTE: CONTRACTOR TO VERIFY ELECTRICAL METER BOX SIZES AND COORDINATE SURROUNDING SIDING FEATURE  
NOTE: CONDENSER UNITS MOUNTED AT GROUND FLOOR LEVEL.

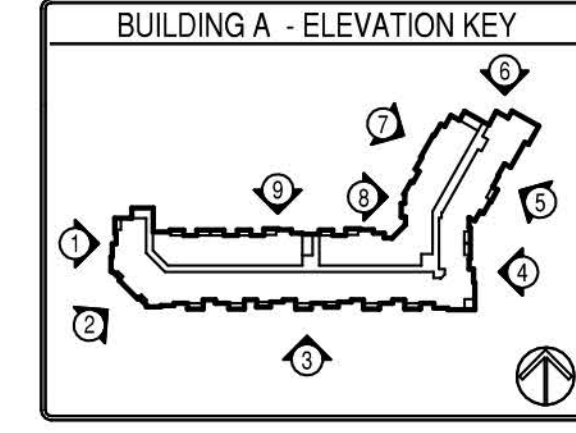

**REVISIONS**

NO.	DATE	DESCRIPTION

**STONEHAWK DENTON 380**  
DENTON, TEXAS  
**STONEHAWK CAPITAL PARTNERS, LLC**



DATE: 07-12-2023  
PROJECT: 22119  
SHEET NUMBER: A4-03

BUILDING A ELEVATIONS

COPYRIGHT © HEDK Architects ALL RIGHTS RESERVED.





**S1- STONE**  
MANUFACTURE:  
EL DOMADO STONE  
COLOR:  
GLACIER



**R1- ROOF**  
MANUFACTURE:  
GAF  
COLOR:  
PEWTER GRAY



**P1- PAINT**  
MANUFACTURE:  
SHERWIN WILLIAMS  
COLOR:  
WEB GRAY  
SW 7075



**P2- PAINT**  
MANUFACTURE:  
SHERWIN WILLIAMS  
COLOR:  
PASSIVE  
SW 7064



**P3- PAINT**  
MANUFACTURE:  
SHERWIN WILLIAMS  
COLOR:  
CLASSIC FRENCH GRAY  
SW 0077

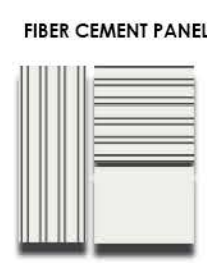

**P4- PAINT**  
MANUFACTURE:  
SHERWIN WILLIAMS  
COLOR:  
EXTRA WHITE  
SW 7009

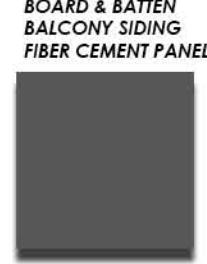

**P5- PAINT**  
MANUFACTURE:  
SHERWIN WILLIAMS  
COLOR:  
IRON ORE  
SW 7069



**M1- METAL ROOF**  
MANUFACTURE:  
REBRIDGE  
COLOR:  
CITYSCAPE



**D1- DOWNSPOUTS**  
MANUFACTURE:  
SENOKI  
COLOR:  
TUXEDO GRAY



**W1- WINDOWS**  
MANUFACTURE:  
PLYGEM  
COLOR:  
WHITE



**ELEVATION KEY**  
SCALE: 1' = 1/16"



**9a BUILDING A - REAR ELEVATION - PART A**  
SCALE: 1' = 1/8"



**9b BUILDING A - REAR ELEVATION - PART B**  
SCALE: 1' = 1/8"

ELEVATION LEGEND	
T.O.H. =	TOP OF HEEL
T.O.D. =	TOP OF DECK
T.O.P. =	TOP OF PLATE
T.O.F. =	TOP OF FOUNDATION

MATERIALS KEY	
	COMPOSITION SHINGLES
	STONE
	FIBER CEMENT BOARD & BATTEN SIDING
	FIBER CEMENT LAP SIDING
	FIBER CEMENT PANEL

NOTE: CONTRACTOR TO VERIFY ELECTRICAL METER BOX SIZES AND COORDINATE SURROUNDING SIDING FEATURE

NOTE: CONDENSER UNITS MOUNTED AT GROUND FLOOR LEVEL.

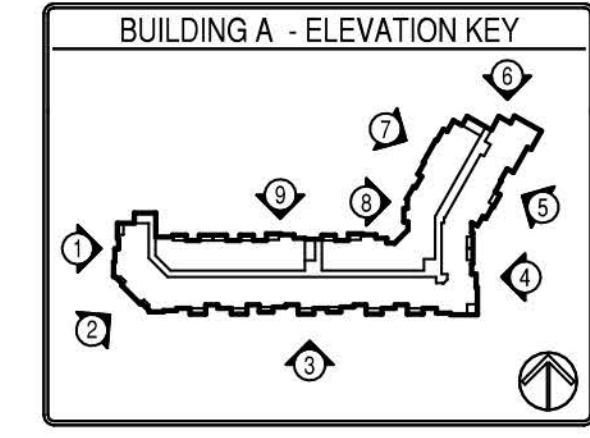

REVISIONS	

**STONEHAWK DENTON 380**  
DENTON, TEXAS  
**STONEHAWK CAPITAL PARTNERS, LLC**



DATE: 07-12-2023  
PROJECT: 22119  
SHEET NUMBER

**A4-04**  
BUILDING A  
ELEVATIONS

COPYRIGHT © HEDK Architects ALL RIGHTS RESERVED





**ELEVATION KEY**  
SCALE: 1" = 1/16"

**ELEVATION LEGEND**

T.O.H. = TOP OF HEEL  
T.O.D. = TOP OF DECK  
T.O.P. = TOP OF PLATE  
T.O.F. = TOP OF FOUNDATION

**MATERIALS KEY**

- COMPOSITION SHINGLES
- STONE
- FIBER CEMENT BOARD & BATTEN SIDING
- FIBER CEMENT LAP SIDING
- FIBER CEMENT PANEL

NOTE: CONTRACTOR TO VERIFY ELECTRICAL METER BOX SIZES AND COORDINATE SURROUNDING SIDING FEATURE  
NOTE: CONDENSER UNITS MOUNTED AT GROUND FLOOR LEVEL.

**REVISIONS**

NO.	DATE	DESCRIPTION



**1a BUILDING B - FRONT ELEVATION - PART A**  
SCALE: 1" = 1/8"

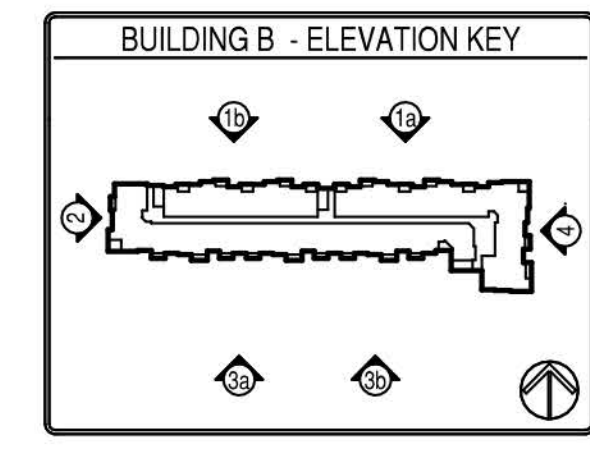

<p><b>S1 - STONE</b> MANUFACTURE: EL DORADO STONE COLOR: GLACIER</p>	<p><b>R1 - ROOF</b> MANUFACTURE: GAF COLOR: PEWTER GRAY</p>	<p><b>F1 - PAINT</b> MANUFACTURE: SHERWIN WILLIAMS COLOR: WEB GRAY SW 7075</p>
<p><b>P2 - PAINT</b> MANUFACTURE: SHERWIN WILLIAMS COLOR: PASSIVE SW 7064</p>	<p><b>P3 - PAINT</b> MANUFACTURE: SHERWIN WILLIAMS COLOR: CLASSIC FRENCH GRAY SW 0077</p>	<p><b>P4 - PAINT</b> MANUFACTURE: SHERWIN WILLIAMS COLOR: EXTRA WHITE SW 7006</p>
<p><b>SIDING, FIBER CEMENT PANEL</b></p>	<p><b>FIBER CEMENT PANEL</b></p>	<p><b>BOARD &amp; BATTEN BALCONY SIDING, FIBER CEMENT PANEL</b></p>
<p><b>P5 - PAINT</b> MANUFACTURE: SHERWIN WILLIAMS COLOR: IRON ORE SW 7069</p>	<p><b>M1 - METAL ROOF</b> MANUFACTURE: BERTRIDGE COLOR: CITYSCAPE</p>	<p><b>D1 - DOWNSPOUTS</b> MANUFACTURE: SENNOX COLOR: TUXEDO GRAY</p>
<p><b>TRIM, FASCIA, RAILING &amp; FOAM BAND</b></p>	<p><b>W1 - WINDOWS</b> MANUFACTURE: PLYGEM COLOR: WHITE</p>	



**1b BUILDING B - FRONT ELEVATION - PART B**  
SCALE: 1" = 1/8"

**STONEHAWK DENTON 380**  
DENTON, TEXAS  
**STONEHAWK CAPITAL PARTNERS, LLC**



DATE: 07-12-2023  
PROJECT: 22119  
SHEET NUMBER:

**A4-10**  
BUILDING B ELEVATIONS

COPYRIGHT © HEDK Architects ALL RIGHTS RESERVED





**ELEVATION KEY**  
SCALE: 1" = 1/16"

3a

3b

**ELEVATION LEGEND**

T.O.H. = TOP OF HEEL  
T.O.D. = TOP OF DECK  
T.O.P. = TOP OF PLATE  
T.O.F. = TOP OF FOUNDATION

**MATERIALS KEY**

- COMPOSITION SHINGLES
- STONE
- FIBER CEMENT BOARD & BATTEN SIDING
- FIBER CEMENT LAP SIDING
- FIBER CEMENT PANEL

NOTE: CONTRACTOR TO VERIFY ELECTRICAL METER BOX SIZES AND COORDINATE SURROUNDING SIDING FEATURE

NOTE: CONDENSER UNITS MOUNTED AT GROUND FLOOR LEVEL

REVISIONS

NO.	DATE	DESCRIPTION

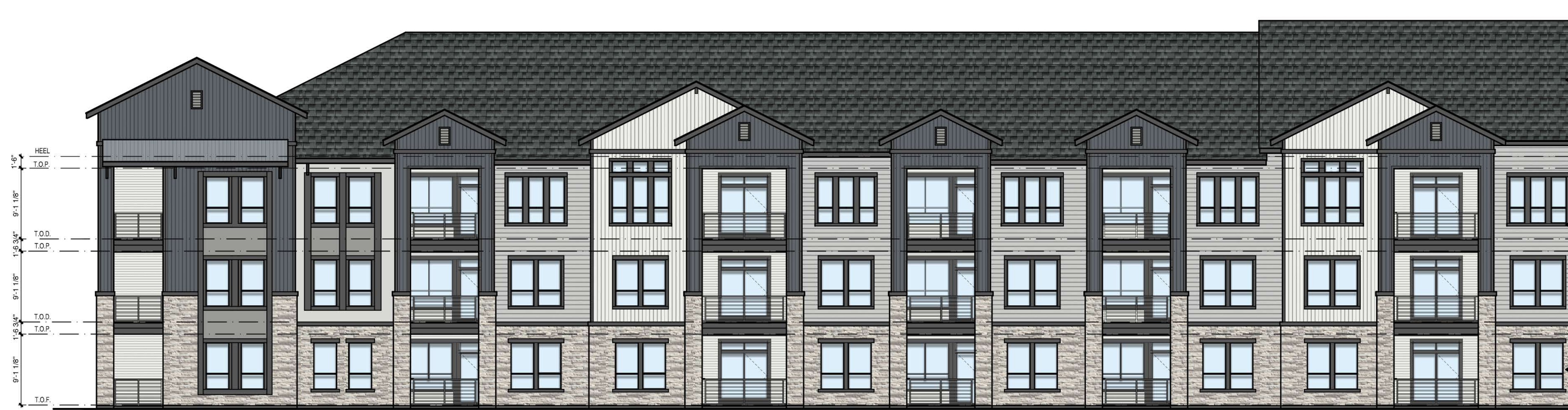

**3a BUILDING B - REAR ELEVATION - PART A**  
SCALE: 1" = 1/8"

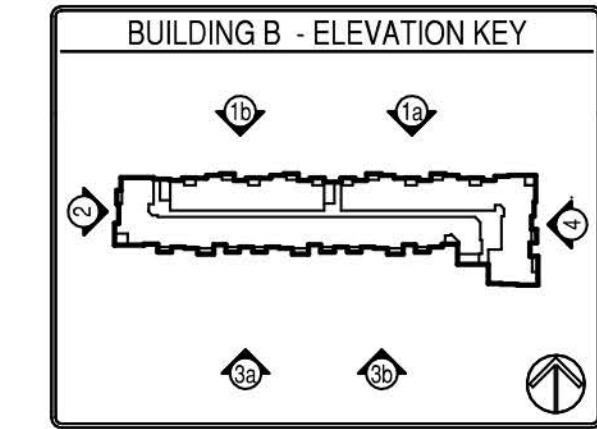

BUILDING B - ELEVATION KEY

**S1- STONE**  
MANUFACTURE: EL DORADO STONE  
COLOR: GLACIER

**R1- ROOF**  
MANUFACTURE: GAF  
COLOR: FEWTER GRAY

**F1- PAINT**  
MANUFACTURE: SHERWIN WILLIAMS  
COLOR: WEB GRAY SW 7075

**P2- PAINT**  
MANUFACTURE: SHERWIN WILLIAMS  
COLOR: PASSIVE SW 7064

**P3- PAINT**  
MANUFACTURE: SHERWIN WILLIAMS  
COLOR: CLASSIC FRENCH GRAY SW 0077

**P4- PAINT**  
MANUFACTURE: SHERWIN WILLIAMS  
COLOR: EXTRA WHITE SW 7006

**P5- PAINT**  
MANUFACTURE: SHERWIN WILLIAMS  
COLOR: IRON ORE SW 7069

**M1- METAL ROOF**  
MANUFACTURE: BERRIDGE  
COLOR: CITYSCAPE

**D1- DOWNSPOUTS**  
MANUFACTURE: SENOX  
COLOR: TUXEDO GRAY

**TRIM, FASCIA, RAILING & FOAM BAND**

**W1- WINDOWS**  
MANUFACTURE: PLYGEM  
COLOR: WHITE



**3b BUILDING B - REAR ELEVATION - PART B**  
SCALE: 1" = 1/8"

**STONEHAWK DENTON 380**  
DENTON, TEXAS  
**STONEHAWK CAPITAL PARTNERS, LLC**



DATE  
07-12-2023

PROJECT  
22119

SHEET NUMBER

**A4-11**  
BUILDING B  
ELEVATIONS

COPYRIGHT © HEDK Architects ALL RIGHTS RESERVED





**S1- STONE**  
MANUFACTURE:  
EL DOMADO STONE  
COLOR:  
GLACIER



**R1- ROOF**  
MANUFACTURE:  
GAF  
COLOR:  
PEWTER GRAY



**P1- PAINT**  
MANUFACTURE:  
SHERWIN WILLIAMS  
COLOR:  
WEB GRAY  
SW 7075



**P2- PAINT**  
MANUFACTURE:  
SHERWIN WILLIAMS  
COLOR:  
PASSIVE  
SW 7064

**SIDING,  
FIBER CEMENT PANEL**



**P3- PAINT**  
MANUFACTURE:  
SHERWIN WILLIAMS  
COLOR:  
CLASSIC FRENCH GRAY  
SW 0077

**FIBER CEMENT PANEL**



**P4- PAINT**  
MANUFACTURE:  
SHERWIN WILLIAMS  
COLOR:  
EXTRA WHITE  
SW 7009

**BOARD & BATTEN  
BALCONY SIDING  
FIBER CEMENT PANEL**



**P5- PAINT**  
MANUFACTURE:  
SHERWIN WILLIAMS  
COLOR:  
IRON ORE  
SW 7069

**TRIM, FASCIA, RAILING &  
FOAM TRIM**



**M1- METAL ROOF**  
MANUFACTURE:  
REBRIDGE  
COLOR:  
CITYSCAPE

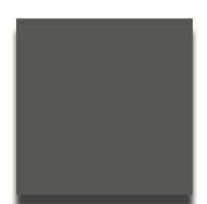

**D1- DOWNSPOUTS**  
MANUFACTURE:  
SENOK  
COLOR:  
TUXEDO GRAY



**W1- WINDOWS**  
MANUFACTURE:  
PLYGEM  
COLOR:  
WHITE

**ELEVATION LEGEND**

T.O.H. = TOP OF HEEL  
T.O.D. = TOP OF DECK  
T.O.P. = TOP OF PLATE  
T.O.F. = TOP OF FOUNDATION

**MATERIALS KEY**

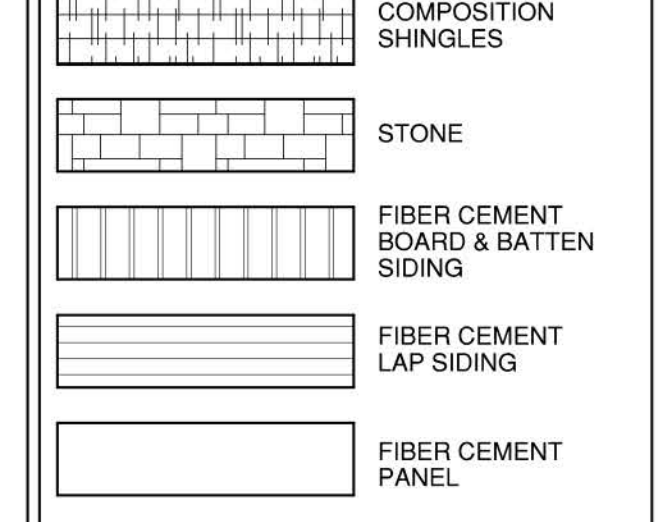

NOTE: CONTRACTOR TO VERIFY ELECTRICAL  
METER BOX SIZES AND COORDINATE  
SURROUNDING SIDING FEATURE  
NOTE: CONDENSER UNITS MOUNTED AT  
GROUND FLOOR LEVEL.

**BUILDING B - ELEVATION KEY**

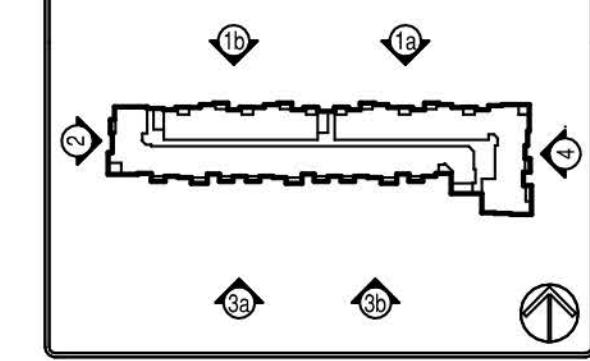

**REVISIONS**

NO.	DATE	DESCRIPTION

**STONEHAWK DENTON 380**  
DENTON, TEXAS  
**STONEHAWK CAPITAL PARTNERS, LLC**



DATE: 07-12-2023  
PROJECT: 22119  
SHEET NUMBER: A4-12

**A4-12**  
BUILDING B  
ELEVATIONS

COPYRIGHT © HECK Architects ALL RIGHTS RESERVED



**4 BUILDING B - SIDE ELEVATION**  
SCALE: 1" = 1/8"



**2 BUILDING B - SIDE ELEVATION**  
SCALE: 1" = 1/8"

















**ELEVATION KEY**  
SCALE: 1' = 1/16"

REVISIONS

NO.	DATE	DESCRIPTION

**ELEVATION LEGEND**

T.O.H. = TOP OF HEEL  
T.O.D. = TOP OF DECK  
T.O.P. = TOP OF PLATE  
T.O.F. = TOP OF FOUNDATION

**MATERIALS KEY**

- COMPOSITION SHINGLES
- STONE
- FIBER CEMENT BOARD & BATTEN SIDING
- FIBER CEMENT LAP SIDING
- FIBER CEMENT PANEL

NOTE: CONTRACTOR TO VERIFY ELECTRICAL METER BOX SIZES AND COORDINATE SURROUNDING SIDING FEATURE  
NOTE: CONDENSER UNITS MOUNTED AT GROUND FLOOR LEVEL.

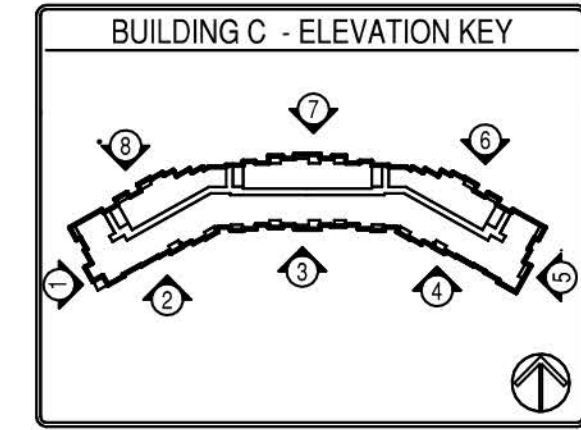

**STONEHAWK DENTON 380**  
DENTON, TEXAS  
**STONEHAWK CAPITAL PARTNERS, LLC**



**6 BUILDING C - REAR ELEVATION**  
SCALE: 1' = 1/8"

<b>S1- STONE</b> MANUFACTURE: EL DORADO STONE COLOR: GLACIER	<b>R1- ROOF</b> MANUFACTURE: GAF COLOR: PEWTER GRAY	<b>P1- PAINT</b> MANUFACTURE: SHERWIN WILLIAMS COLOR: WEB GRAY SW 7075
<b>P2- PAINT</b> MANUFACTURE: SHERWIN WILLIAMS COLOR: PASSIVE SW 7064	<b>P3- PAINT</b> MANUFACTURE: SHERWIN WILLIAMS COLOR: CLASSIC FRENCH GRAY SW 0077	<b>BOARD &amp; BATTEN</b> MANUFACTURE: SHERWIN WILLIAMS COLOR: EXTRA WHITE SW 7006
<b>SIDING: FIBER CEMENT PANEL</b>	<b>FIBER CEMENT PANEL</b>	<b>BOARD &amp; BATTEN BALCONY SIDING: FIBER CEMENT PANEL</b>
<b>P5- PAINT</b> MANUFACTURE: SHERWIN WILLIAMS COLOR: IRON ORE SW 7069	<b>M1- METAL ROOF</b> MANUFACTURE: BERTRIDGE COLOR: CITYSCAPE	<b>D1- DOWNSPOUTS</b> MANUFACTURE: SENOX COLOR: TUXEDO GRAY
<b>TRIM, FASCIA, RAILING &amp; FOAM BAND</b>		
		<b>W1- WINDOWS</b> MANUFACTURE: PLYGEM COLOR: WHITE

**HEDK ARCHITECTS**  
4594 EXCEL PARKWAY ADDISON, TX 75001  
214-520-8876  
hedk.com

DATE  
**07-12-2023**

PROJECT  
**22119**

SHEET NUMBER















**A4-23**  
BUILDING C  
ELEVATIONS

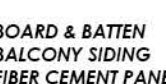

COPYRIGHT © HEDK Architects ALL RIGHTS RESERVED





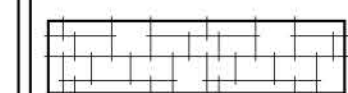
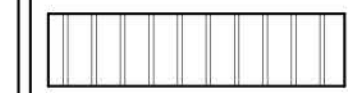
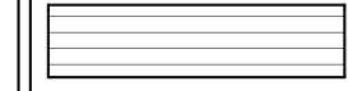

 <b>S1- STONE</b> MANUFACTURE: EL DORADO STONE COLOR: GLACIER	 <b>R1- ROOF</b> MANUFACTURE: GAF COLOR: PEWTER GRAY	 <b>F1- PAINT</b> MANUFACTURE: SHERWIN WILLIAMS COLOR: WEB GRAY SW 7075
 <b>F2- PAINT</b> MANUFACTURE: SHERWIN WILLIAMS COLOR: PASSIVE SW 7044	 <b>F3- PAINT</b> MANUFACTURE: SHERWIN WILLIAMS COLOR: CLASSIC FRENCH GRAY SW 0077	 <b>F4- PAINT</b> MANUFACTURE: SHERWIN WILLIAMS COLOR: EXTRA WHITE SW 7006
 <b>SIDING: FIBER CEMENT PANEL</b>	 <b>FIBER CEMENT PANEL</b>	 <b>BOARD &amp; BATTEN BALCONY SIDING FIBER CEMENT PANEL</b>
 <b>F5- PAINT</b> MANUFACTURE: SHERWIN WILLIAMS COLOR: IRON ORE SW 7069	 <b>M1- METAL ROOF</b> MANUFACTURE: BERRIDGE COLOR: CITYSCAPE	 <b>D1- DOWNSPOUTS</b> MANUFACTURE: SENOKI COLOR: TUXEDO GRAY
 <b>TRIM, FASCIA RAILING &amp; FOAM BAND</b>		
 <b>W1- WINDOWS</b> MANUFACTURE: PLYGEM COLOR: WHITE		

ELEVATION LEGEND	
T.O.H. = TOP OF HEEL	
T.O.D. = TOP OF DECK	
T.O.P. = TOP OF PLATE	
T.O.F. = TOP OF FOUNDATION	
MATERIALS KEY	
	COMPOSITION SHINGLES
	STONE
	FIBER CEMENT BOARD & BATTEN SIDING
	FIBER CEMENT LAP SIDING
	FIBER CEMENT PANEL
NOTE: CONTRACTOR TO VERIFY ELECTRICAL METER BOX SIZES AND COORDINATE SURROUNDING SIDING FEATURE	
NOTE: CONDENSER UNITS MOUNTED AT GROUND FLOOR LEVEL.	

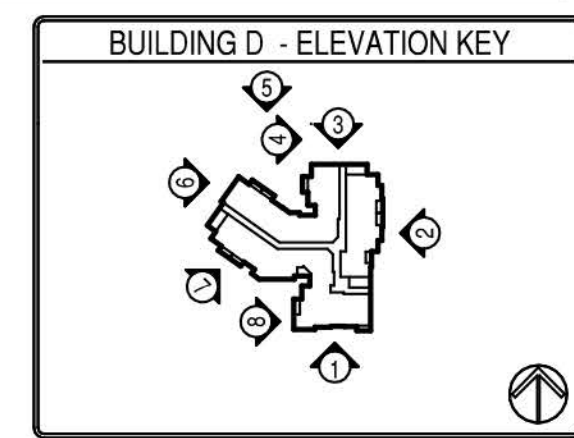

**1** BUILDING D - END ELEVATION  
SCALE: 1" = 1/8"



**2** BUILDING D - FRONT ELEVATION  
SCALE: 1" = 1/8"

REVISIONS

STONEHAWK DENTON 380  
DENTON, TEXAS  
STONEHAWK CAPITAL PARTNERS, LLC



DATE  
07-12-2023

PROJECT  
22119

SHEET NUMBER

**A4-30**  
BUILDING D  
ELEVATIONS

COPYRIGHT © HDK Architects ALL RIGHTS RESERVED





**S1- STONE**  
MANUFACTURE:  
EL DOMADO STONE  
COLOR:  
GLACIER



**R1- ROOF**  
MANUFACTURE:  
GAF  
COLOR:  
PEWTER GRAY



**P1- PAINT**  
MANUFACTURE:  
SHERWIN WILLIAMS  
COLOR:  
WEB GRAY  
SW 7075



**P2- PAINT**  
MANUFACTURE:  
SHERWIN WILLIAMS  
COLOR:  
PASSIVE  
SW 7064

**SIDING,  
FIBER CEMENT PANEL**



**P3- PAINT**  
MANUFACTURE:  
SHERWIN WILLIAMS  
COLOR:  
CLASSIC FRENCH GRAY  
SW 0077



**P4- PAINT**  
MANUFACTURE:  
SHERWIN WILLIAMS  
COLOR:  
EXTRA WHITE  
SW 7006

**BOARD & BATTEN  
BALCONY SIDING  
FIBER CEMENT PANEL**



**P5- PAINT**  
MANUFACTURE:  
SHERWIN WILLIAMS  
COLOR:  
IRON ORE  
SW 7069



**M1- METAL ROOF**  
MANUFACTURE:  
SERENICE  
COLOR:  
CITYSCAPE



**D1- DOWNSPOUTS**  
MANUFACTURE:  
SENOK  
COLOR:  
TUXEDO GRAY



**W1- WINDOWS**  
MANUFACTURE:  
PLYGEM  
COLOR:  
WHITE



**3 BUILDING D - END ELEVATION**  
SCALE: 1" = 1/8"



**4 BUILDING D - REAR ELEVATION**  
SCALE: 1" = 1/8"



**5 BUILDING D - REAR ELEVATION**  
SCALE: 1" = 1/8"



**6 BUILDING D - END ELEVATION**  
SCALE: 1" = 1/8"

**ELEVATION LEGEND**

T.O.H. = TOP OF HEEL  
T.O.D. = TOP OF DECK  
T.O.P. = TOP OF PLATE  
T.O.F. = TOP OF FOUNDATION

**MATERIALS KEY**

- COMPOSITION SHINGLES
- STONE
- FIBER CEMENT BOARD & BATTEN SIDING
- FIBER CEMENT LAP SIDING
- FIBER CEMENT PANEL

NOTE: CONTRACTOR TO VERIFY ELECTRICAL METER BOX SIZES AND COORDINATE SURROUNDING SIDING FEATURE  
NOTE: CONDENSER UNITS MOUNTED AT GROUND FLOOR LEVEL

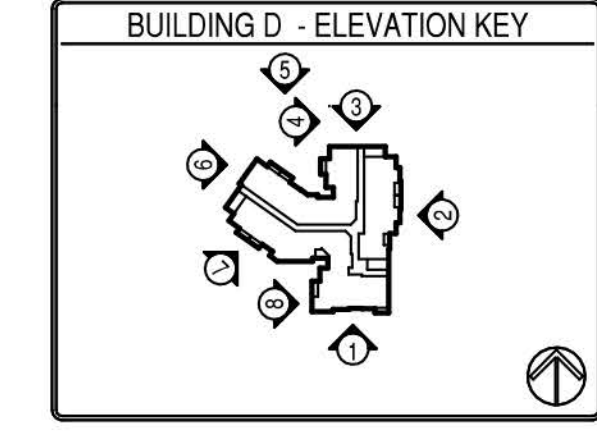

**REVISIONS**

NO.	DESCRIPTION

**STONEHAWK DENTON 380**  
DENTON, TEXAS  
**STONEHAWK CAPITAL PARTNERS, LLC**



DATE  
**07-12-2023**

PROJECT  
**22119**

SHEET NUMBER

**A4-31**  
BUILDING D  
ELEVATIONS

COPYRIGHT © HEDK Architects ALL RIGHTS RESERVED

4595 EXCEL PARKWAY ADDISON, TX 75001  
214-350-8875  
hedk.com





**S1- STONE**  
MANUFACTURE:  
EL DOMADO STONE  
COLOR:  
GLACIER



**R1- ROOF**  
MANUFACTURE:  
GAF  
COLOR:  
PEWTER GRAY



**P1- PAINT**  
MANUFACTURE:  
SHERWIN WILLIAMS  
COLOR:  
WEB GRAY  
SW 7075



**P2- PAINT**  
MANUFACTURE:  
SHERWIN WILLIAMS  
COLOR:  
PASSIVE  
SW 7064

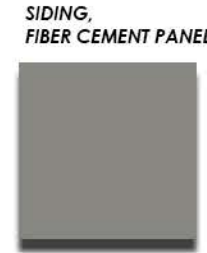

**P3- PAINT**  
MANUFACTURE:  
SHERWIN WILLIAMS  
COLOR:  
CLASSIC FRENCH GRAY  
SW 0077



**P4- PAINT**  
MANUFACTURE:  
SHERWIN WILLIAMS  
COLOR:  
EXTRA WHITE  
SW 7009



**P5- PAINT**  
MANUFACTURE:  
SHERWIN WILLIAMS  
COLOR:  
IRON ORE  
SW 7069



**M1- METAL ROOF**  
MANUFACTURE:  
REBRIDGE  
COLOR:  
CITYSCAPE



**D1- DOWNSPOUTS**  
MANUFACTURE:  
SENOK  
COLOR:  
TUXEDO GRAY



**W1- WINDOWS**  
MANUFACTURE:  
PLYGEM  
COLOR:  
WHITE



**7 BUILDING D - REAR ELEVATION**  
SCALE: 1' = 1/8"



**8 BUILDING D - REAR ELEVATION**  
SCALE: 1' = 1/8"

**ELEVATION LEGEND**

T.O.H. = TOP OF HEEL  
T.O.D. = TOP OF DECK  
T.O.P. = TOP OF PLATE  
T.O.F. = TOP OF FOUNDATION

**MATERIALS KEY**

- COMPOSITION SHINGLES
- STONE
- FIBER CEMENT BOARD & BATTEN SIDING
- FIBER CEMENT LAP SIDING
- FIBER CEMENT PANEL

NOTE: CONTRACTOR TO VERIFY ELECTRICAL METER BOX SIZES AND COORDINATE SURROUNDING SIDING FEATURE  
NOTE: CONDENSER UNITS MOUNTED AT GROUND FLOOR LEVEL.

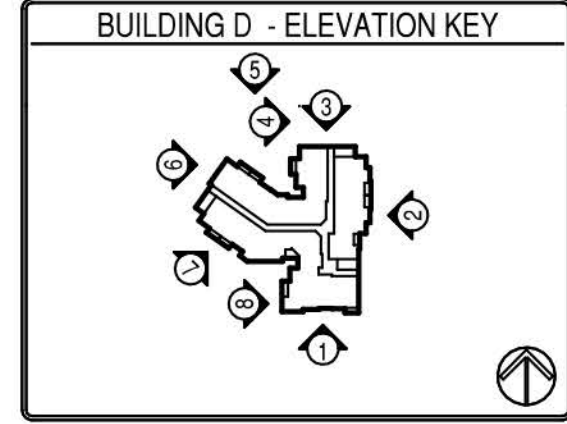

**REVISIONS**

NO.	DATE	DESCRIPTION

**STONEHAWK DENTON 380**  
DENTON, TEXAS  
**STONEHAWK CAPITAL PARTNERS, LLC**



DATE: 07-12-2023  
PROJECT: 22119  
SHEET NUMBER: A4-32

**A4-32**  
BUILDING D  
ELEVATIONS

COPYRIGHT © HEDK Architects ALL RIGHTS RESERVED



## **Modern Farmhouse Architectural Elements**

The appearance of the overall development is proposed “modern farmhouse” that is intended to have architectural compatibility with surrounding residential units. This architectural style is comprised of clean vertical or horizontal lines, standing seam roofs, transom windows, cupolas, pergola outdoor seating areas, sconces and awnings. This architectural vernacular uses materials that are neutral and monotone, easy to clean and wear well over time without rot or color fade.

### **Variation from Base Zoning (Subdistrict B: Commercial, SC Base Zoning).**

The commercial and multifamily portions may use a design style that is consistent with “modern farmhouse”. These materials are unique and timeless. The style uses building materials that are softer in appearance (more accepting to the patron than say for instance, brick or concrete, which are perceived as colder and harder materials) and monotone in color (making for a more pleasing commercial or residential experience). This has a benefit to the development and nearby residents: the style is consistent with the residents’ homes in the immediate area and this style lends well to using various timeless outdoor site features (more festive) that are consistent with this style (arbors, patios, heavy timber lighting, etc).



Modern Farmhouse Style – Example 1





Modern Farmhouse Style – Example 1



Modern Farmhouse Style – Example 3





Modern Farmhouse Style – Example 4



Modern Farmhouse Style – Example 5





Modern Farmhouse Style – Example 6



Modern Farmhouse Style – Example 7





Modern Farmhouse Style – Example 8





The commercial portion may implement open space in the form of a water feature. By doing so, the quality of this feature must use techniques and development standards that deviate from the existing development standards. The intention is to provide a unique dining experience (if a water feature is implemented) that will extend the indoor space into the outdoors.



Example of deck-over water feature



Example of extending the indoor space to the outdoors